

# **ARMY TB 9-2320-302-13&P-1 AIR FORCE T.O. 36A12-1C-1600-11-1**

---

## **TECHNICAL BULLETIN**

**OPERATOR'S, UNIT AND DIRECT SUPPORT  
MAINTENANCE MANUAL, INSTALLATION INSTRUCTIONS, AND  
REPAIR PARTS AND SPECIAL TOOLS LISTS (RPSTL)**

**FOR  
CREW PROTECTION KIT**

**FOR  
TRUCK, TRACTOR, LINE-HAUL:  
52,000 GVWR, 6 X 4, M915A3P1  
NSN: 2320-01-523-2486**

**TRUCK, TRACTOR, LINE-HAUL:  
52,000 GVWR, 6 X 4, M915A2P1  
NSN: 2320-01-523-2482**

**TRUCK, TRACTOR, LIGHT EQUIPMENT TRANSPORTER (LET):  
68,000 GVWR, 6 X 6, W/WINCH, M916A3P1  
NSN: 2320-01-531-2636**

**TRUCK, DUMP, HEAVY, CHASSIS:  
68,000 GVWR, 6 X 6, 14 CU YD, ON-OFF HIGHWAY, M917A2P1  
NSN: 2320-01-531-2637**

**TRUCK, TRACTOR, LINE-HAUL:  
52,000 GVWR, 6 X 4, M915A4P1  
NSN: 2320-01-523-2632**

**TRUCK, DUMP, HEAVY, CHASSIS:  
68,000 GVWR, 6 X 6, 14 CU YD, ON-OFF HIGHWAY, M917A1P1  
NSN: 2320-01-531-2632**

**TRUCK, TRACTOR, LIGHT EQUIPMENT TRANSPORTER (LET):  
68,000 GVWR, 6 X 6, W/WINCH, M916A1P1  
NSN: 2320-01-531-2629**

**TRUCK, TRACTOR, LIGHT EQUIPMENT TRANSPORTER (LET):  
68,000 GVWR, 6 X 6, W/WINCH, M916A2P1  
NSN: 2320-01-531-2634**

**DISTRIBUTION STATEMENT A - Approved for public release; distribution is unlimited**

---

**HEADQUARTERS, DEPARTMENTS OF THE ARMY AND AIR FORCE**

**30 NOVEMBER 2006**



## WARNING SUMMARY

This warning summary contains general safety warnings and hazardous materials warnings that must be understood and applied during operation and maintenance of this equipment. Failure to observe these precautions may cause serious injury or death to personnel. Also included are explanations of safety and hazardous materials icons used within this technical bulletin.



CHEMICAL - drops of liquid on hand shows that the material will cause burns or irritation to human skin or tissue.



EYE PROTECTION - person with goggles shows that the material will injure the eyes.



FIRE - flame shows that a material may ignite and cause burns.



FLYING PARTICLES - arrows bouncing off face with face shield shows that particles flying through the air will harm face.



HEAVY PARTS - hand with heavy object on top shows that heavy parts can crush and harm.



HEAVY PARTS - heavy object on human figure shows that heavy parts present a danger to life or limb.



VAPOR - human figure in a cloud shows that material vapors present a danger to life or health.

NOTE

For information on first aid, refer to FM 4-25.11.



WARNING

*ADHESIVES AND SEALANTS*

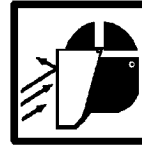


Use caution when using adhesives and sealants. Prolonged inhalation of vapors can cause lung irritation. Contact with skin can cause dermatitis. Wear gloves and safety goggles and use product in a well-ventilated area away from open flame. If ingested, keep individual calm and seek medical attention. DO NOT induce vomiting. If contact with skin or eyes is made, flush thoroughly with water. Dispose of cleanup rags IAW local policy and ordinances. Failure to follow this warning may cause injury to personnel.



WARNING

*COMPRESSED AIR*



Particles blown by compressed air are hazardous. DO NOT exceed 15 psi (103 kPa) nozzle pressure when drying parts with compressed air. Use a maximum of 30 psi (207 kPa) when cleaning components. DO NOT direct compressed air against human skin. Failure to follow this warning may result in injury or death to personnel. Make sure air stream is directed away from user and other personnel in the area. To prevent injury, user must wear protective goggles or face shield.



WARNING

*DRILLING AND RIVETING*

Eye protection is required when drilling and when using riveter to install rivets. Failure to follow this warning may cause injury to personnel.



WARNING

*HEAVY COMPONENTS*



Use extreme caution when handling heavy parts. Provide adequate support and use assistance during procedure. Ensure that any lifting device used is in good condition and of suitable load capacity. Keep clear of heavy parts supported only by lifting device. Failure to follow this warning may cause injury or death to personnel.



WARNING

Use extreme caution when handling heavy parts. Provide adequate support and use assistance during procedure. Failure to follow this warning may cause injury or death to personnel.

## WARNING

### *VEHICLE OPERATION*

Due to increased weight with CPK installed, operator should be aware of differences in vehicle's driving characteristics and adjust driving accordingly. Failure to do so may cause injury or death to personnel.

## WARNING

- The center of gravity is higher on a vehicle with a Crew Protection Kit installed.
- Always use slower speed when operating vehicle.
- DO NOT operate vehicle on steep hills or inclines.
- Failure to follow these warnings may cause injury or death to personnel.

## WARNING

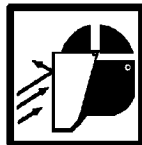
Visibility is reduced on a vehicle with a Crew Protection Kit installed. Always use ground guides when maneuvering vehicle near obstacles. Failure to follow this warning may cause injury to personnel or damage to equipment.

## WARNING

Vehicles with a Crew Protection Kit installed have different door handles and latching hardware. Do not allow clothing or equipment to catch on door hardware. Failure to follow this warning may cause injury to personnel.

## WARNING

DO NOT park vehicle on a hill or incline. The parking brake has a reduced capacity due to the increased weight of vehicle with Crew Protection Kit installed. Failure to follow this warning may cause injury or death to personnel.



## WARNING

### *SHARP EDGES*

- Use caution when handling window glass. Glass can break unexpectedly during removal/installation procedure. Wear face shield, apron, and gloves. Failure to follow this warning may cause injury to personnel.
- Edges of metal armor panels may be sharp. Wear protective gloves when handling armor panels. Failure to follow this warning may cause injury to personnel.



## WARNING

### *HAZARDOUS WASTE DISPOSAL*

When servicing this machine, performing maintenance or disposing of materials such as engine coolant, hydraulic fluid, lubricants, battery acids or batteries and CARC paint, consult your unit/local hazardous waste disposal center or safety office for local regulatory guidance. If further information is needed, please contact The Army Environmental Hotline at 1-800-872-3845.



## WARNING

### ***SOLVENT CLEANING COMPOUND***



- Solvent cleaning compound MIL-PRF-680 Type III is an environmentally compliant and low toxic material. However, it may be irritating to the eyes and skin. Use protective gloves and goggles. Use in well-ventilated areas. Keep away from open flames and other sources of ignition. Failure to follow this warning may cause injury to personnel.
- Improper cleaning methods and use of unauthorized cleaning solvents may injure personnel and damage equipment. Refer to TM 9-247, *Materials Used for Cleaning, Preserving, Abrading, and Cementing Ordnance Materiels and Related Materiels Including Chemicals*, for correct information.
- Fire extinguishers should be placed nearby when using solvent cleaning compound.
- Cloths or rags saturated with solvent cleaning compound must be disposed of IAW authorized facilities' procedures.
- Eye shields must be worn when cleaning with a wire brush. Flying rust and metal particles may cause injury.
- Particles blown by compressed air are hazardous. DO NOT exceed 15 psi (103 kPa) nozzle pressure when drying parts with compressed air. Use a maximum of 30 psi (207 kPa) when cleaning components. DO NOT direct compressed air against human skin. Failure to follow this warning may result in injury or death. Make sure air stream is directed away from user and other personnel in the area. To prevent injury, user must wear protective goggles or face shield.

## WARNING

### ***THREAT PROTECTION***

For proper threat protection, ballistic glass must be correctly installed onto ballistic glass frame. During installation, ensure that decal "INSTALL THIS SURFACE TOWARDS THREAT" is located on outside of cab. Improperly installed windshield ballistic glass will not protect occupants. Failure to follow this warning may cause injury or death to personnel.

## WARNING

### ***WELDING NOT AUTHORIZED***

To ensure survivability of personnel, welding repairs on armor kit are NOT authorized. If armor plates are damaged, they must be replaced. Failure to follow this warning may cause failure of armor, resulting in injury or death to personnel.

TB 9-2320-302-13&P-1  
T.O. 36A12-1C-1600-11-1

Change  
No. 1

HEADQUARTERS  
DEPARTMENTS OF THE ARMY AND AIR FORCE  
WASHINGTON, D.C., 30 NOVEMBER 2007

TECHNICAL BULLETIN

OPERATOR'S, UNIT AND DIRECT SUPPORT  
MAINTENANCE MANUAL, INSTALLATION INSTRUCTIONS, AND  
REPAIR PARTS AND SPECIAL TOOLS LISTS (RPSTL)  
FOR

CREW PROTECTION KIT  
FOR

TRUCK, TRACTOR, LINE-HAUL:

52,000 GVWR, 6 X 4, M915A3P1

NSN: 2320-01-523-2486

TRUCK, TRACTOR, LINE-HAUL:

52,000 GVWR, 6 X 4, M915A2P1

NSN: 2320-01-523-2482

TRUCK, TRACTOR, LIGHT EQUIPMENT TRANSPORTER (LET):

68,000 GVWR, 6 X 6, W/WINCH, M916A3P1

NSN: 2320-01-531-2636

TRUCK, DUMP, HEAVY, CHASSIS:

68,000 GVWR, 6 X 6, 14 CU YD, ON-OFF HIGHWAY, M917A2P1

NSN: 2320-01-531-2637

TRUCK, TRACTOR, LINE-HAUL:

52,000 GVWR, 6 X 4, M915A4P1

NSN: 2320-01-523-2484

TRUCK, DUMP, HEAVY, CHASSIS:

68,000 GVWR, 6 X 6, 14 CU YD, ON-OFF HIGHWAY, M917A1P1

NSN: 2320-01-531-2632

TRUCK, TRACTOR, LIGHT EQUIPMENT TRANSPORTER (LET):

68,000 GVWR, 6 X 6, W/WINCH, M916A1P1

NSN: 2320-01-531-2629

TRUCK, TRACTOR, LIGHT EQUIPMENT TRANSPORTER (LET):

68,000 GVWR, 6 X 6, W/WINCH, M916A2P1

NSN: 2320-01-531-2634

**DISTRIBUTION STATEMENT A** - Approved for public release; distribution is unlimited.

TB 9-2320-302-13&P-1, 30 November 2006, is updated as follows:

1. File this sheet in front of manual for reference.
2. This change is a result of expanding technical bulletin to joint service use.
3. New or updated text is indicated by a vertical bar in outer margin of the page.
4. Remove old pages and insert new pages as indicated below:

**Remove Pages**

A/B Blank  
i-vi  
DA 2028 (2 copies)  
Cover

**Insert Pages**

A/B Blank  
i-vi  
DA 2028 (3 copies)  
CoverDE

**ARMY TB 9-2320-302-13&P-1**  
**AIR FORCE T.O. 36A12-1C-1600-11-1**  
**C1**

By Order of the Secretary of the Army:

GEORGE W. CASEY, JR.  
*General, United States Army*  
*Chief of Staff*

Official:



JOYCE E. MORROW  
*Administrative Assistant to the*  
*Secretary of the Army*  
0731101

JOHN P. JUMPER  
*General, United States Air Force*  
*Chief of Staff*

Official:

GREGORY S. MARTIN  
*General, United States Air Force*  
*Commander, Air Force Materiel Command*

Distribution:

To be distributed in accordance with the initial distribution number (IDN) 083145,  
requirements for TB 9-2320-302-13&P-1.



**LIST OF EFFECTIVE PAGES/WORK PACKAGES**

Date of issue for original Technical Bulletin is:

Original . . . . . 30 November 2006

Change No. 1 . . 30 November 2007

Total number of pages for front and rear matter is **28** and total number of work packages is 38 consisting of the following:

<b>Page/WP No.</b>	<b>*Change No.</b>	<b>Page/WP No.</b>	<b>*Change No.</b>
Front Cover	1	WP 0028 00 (2 pp.)	0
a—d	0	WP 0029 00 (6 pp.)	0
A/(B Blank)	1	WP 0030 00 (10 pp.)	0
i—vi	1	Ch. 5 title page	0
Ch. 1 title page	0	WP 0031 00 (2 pp.)	0
WP 0001 00 (2 pp.)	0	WP 0032 00 (4 pp.)	0
WP 0002 00 (2 pp.)	0	WP 0033 00 (4 pp.)	0
WP 0003 00 (4 pp.)	0	WP 0034 00 (4 pp.)	0
Ch. 2 title page	0	WP 0035 00 (4 pp.)	0
WP 0004 00 (2 pp.)	0	WP 0036 00 (2 pp.)	0
WP 0005 00 (2 pp.)	0	WP 0037 00 (7 pp.)	0
WP 0006 00 (2 pp.)	0	WP 0038 00 (38 pp.)	0
WP 0007 00 (2 pp.)	0	Index (4 pp.)	0
Ch. 3 title page	0	Metric conversion chart	0
WP 0008 00 (4 pp.)	0	Back cover	0
WP 0009 00 (14 pp.)	0		
WP 0010 00 (2 pp.)	0		
Ch. 4 title page	0		
WP 0011 00 (6 pp.)	0		
WP 0012 00 (4 pp.)	0		
WP 0013 00 (4 pp.)	0		
WP 0014 00 (4 pp.)	0		
WP 0015 00 (4 pp.)	0		
WP 0016 00 (2 pp.)	0		
WP 0017 00 (4 pp.)	0		
WP 0018 00 (4 pp.)	0		
WP 0019 00 (10 pp.)	0		
WP 0020 00 (6 pp.)	0		
WP 0021 00 (6 pp.)	0		
WP 0022 00 (4 pp.)	0		
WP 0023 00 (8 pp.)	0		
WP 0024 00 (10 pp.)	0		
WP 0025 00 (6 pp.)	0		
WP 0026 00 (6 pp.)	0		
WP 0027 00 (2 pp.)	0		



TECHNICAL BULLETIN  
TB 9-2320-302-13&P-1

HEADQUARTERS  
DEPARTMENTS OF THE ARMY AND AIR FORCE  
WASHINGTON, D.C.  
30 NOVEMBER 2006

**TECHNICAL BULLETIN**

**OPERATOR'S, UNIT AND DIRECT SUPPORT  
MAINTENANCE MANUAL, INSTALLATION INSTRUCTIONS, AND  
REPAIR PARTS AND SPECIAL TOOLS LISTS (RPSTL)**

**FOR**

**CREW PROTECTION KIT**

**FOR**

**TRUCK, TRACTOR, LINE-HAUL:**

**52,000 GVWR, 6 X 4, M915A3P1**

**NSN: 2320-01-523-2486**

**TRUCK, TRACTOR, LINE-HAUL:**

**52,000 GVWR, 6 X 4, M915A2P1**

**NSN: 2320-01-523-2482**

**TRUCK, TRACTOR, LIGHT EQUIPMENT TRANSPORTER (LET):**

**68,000 GVWR, 6 X 6, W/WINCH, M916A3P1**

**NSN: 2320-01-531-2636**

**TRUCK, DUMP, HEAVY, CHASSIS:**

**68,000 GVWR, 6 X 6, 14 CU YD, ON-OFF HIGHWAY, M917A2P1**

**NSN: 2320-01-531-2637**

**TRUCK, TRACTOR, LINE-HAUL:**

**52,000 GVWR, 6 X 4, M915A4P1**

**NSN: 2320-01-523-2484**

**TRUCK, DUMP, HEAVY, CHASSIS:**

**68,000 GVWR, 6 X 6, 14 CU YD, ON-OFF HIGHWAY, M917A1P1**

**NSN: 2320-01-531-2632**

**TRUCK, TRACTOR, LIGHT EQUIPMENT TRANSPORTER (LET):**

**68,000 GVWR, 6 X 6, W/WINCH, M916A1P1**

**NSN: 2320-01-531-2629**

**TRUCK, TRACTOR, LIGHT EQUIPMENT TRANSPORTER (LET):**

**68,000 GVWR, 6 X 6, W/WINCH, M916A2P1**

**NSN: 2320-01-531-2634**

DISTRIBUTION STATEMENT A: Approved for public release; distribution is unlimited.

**REPORTING ERRORS AND RECOMMENDING IMPROVEMENTS**

You can help improve this publication. If you find any mistakes or if you know of a way to improve the procedures, please let us know. Submit your DA Form 2028 (*Recommended Changes to Equipment Technical Publications*), through the Internet, on the Army Electronic Product Support (AEPS) website. The Internet address is <https://aeeps.ria.army.mil/>. The DA Form 2028 is located under the Public Applications section in the AEPS Public Home Page. Fill out the form and click on SUBMIT. Using this form on the AEPS will enable us to respond quicker to your comments and better manage the DA Form 2028 program. You may also mail, fax or e-mail your letter or DA Form 2028 directly to: AMSTA-LC-LMPP/TECH PUBS, TACOM-RI, 1 Rock Island Arsenal, Rock Island, IL 61299-7630. The e-mail address is [ROCK-TACOM-TECH-PUBS@conus.army.mil](mailto:ROCK-TACOM-TECH-PUBS@conus.army.mil). The FAX number is DSN 793-0726 or Commercial (309) 782-0726.

**DISTRIBUTION STATEMENT A** - Approved for public release; distribution is unlimited.

Current as of November 2006

**TABLE OF CONTENTS**

	<b>Page Number</b>
Warning Summary.....	a
How To Use This Technical Bulletin .....	v
<b>CHAPTER 1 GENERAL INFORMATION, EQUIPMENT DESCRIPTION AND DATA, AND THEORY OF OPERATION</b>	
WP 0001 00 General Information .....	0001 00-1
WP 0002 00 Equipment Description and Data. ....	0002 00-1
WP 0003 00 Theory of Operation .....	0003 00-1
<b>CHAPTER 2 OPERATOR INSTRUCTIONS</b>	
WP 0004 00 Description and Use of Operator Controls and Indicators .....	0004 00-1
WP 0005 00 Operation Under Usual Conditions .....	0005 00-1
WP 0006 00 Operation Under Unusual Conditions .....	0006 00-1
WP 0007 00 Stowage and Decal/Data Plate Guide .....	0007 00-1
<b>CHAPTER 3 OPERATOR MAINTENANCE INSTRUCTIONS</b>	
WP 0008 00 Operator Preventive Maintenance Checks and Services (PMCS) Introduction .	0008 00-1
WP 0009 00 Operator Preventive Maintenance Checks and Services (PMCS). ....	0009 00-1
WP 0010 00 Cleaning Ballistic Glass .....	0010 00-1
<b>CHAPTER 4 UNIT MAINTENANCE INSTRUCTIONS</b>	
WP 0011 00 General Maintenance Instructions. ....	0011 00-1
WP 0012 00 Door Assembly Replacement .....	0012 00-1
WP 0013 00 Door Handle Replacement .....	0013 00-1
WP 0014 00 Door Latch Replacement. ....	0014 00-1
WP 0015 00 Door Ballistic Glass and Frame Assembly Replacement .....	0015 00-1
WP 0016 00 Door Latch Adjustment. ....	0016 00-1
WP 0017 00 Cab Support Reinforcement Replacement .....	0017 00-1
WP 0018 00 Wheel Zone Deflector Replacement .....	0018 00-1
WP 0019 00 Floor Armor Replacement. ....	0019 00-1
WP 0020 00 Right Side Armor Replacement. ....	0020 00-1
WP 0021 00 Left Side Armor Replacement. ....	0021 00-1
WP 0022 00 A-Pillar Armor Replacement. ....	0022 00-1
WP 0023 00 Rear Armor Replacement .....	0023 00-1
WP 0024 00 Roof Armor Replacement .....	0024 00-1
WP 0025 00 Windshield Ballistic Glass Replacement. ....	0025 00-1

**TABLE OF CONTENTS, CONTINUED**

	<b>Page Number</b>
WP 0026 00 Firewall Armor Replacement .....	0026 00-1
WP 0027 00 Escape Hatch Replacement .....	0027 00-1
WP 0028 00 Cowl Armor Replacement .....	0028 00-1
WP 0029 00 Front Armor Replacement .....	0029 00-1
WP 0030 00 Foam Insulation Replacement .....	0030 00-1

**CHAPTER 5 SUPPORTING INFORMATION**

WP 0031 00 References .....	0031 00-1
WP 0032 00 Maintenance Allocation Chart (MAC) Introduction .....	0032 00-1
WP 0033 00 Maintenance Allocation Chart (MAC) .....	0033 00-1
WP 0034 00 Expendable and Durable Items List .....	0034 00-1
WP 0035 00 Torque Limits .....	0035 00-1
WP 0036 00 Crew Protection Kit Installation Instructions .....	0036 00-1
WP 0037 00 Field Maintenance (Unit and Direct Support Maintenance) Repair Parts and Special Tools Lists (RPSTL) Introduction .....	0037 00-1
WP 0038 00 Repair Parts and Special Tools List (RPSTL) .....	0038 00-1

GROUP 33 SPECIAL PURPOSE KITS

3307 - SPECIAL PURPOSE KITS .....	1-1
CAB SUPPORT REINFORCEMENT KIT .....	1 1-1
WHEEL HOUSING ARMOR KIT .....	2 2-1
INTERIOR PROTECTION ARMOR KIT .....	3 3-1
SIDE PROTECTION ARMOR KIT .....	4 4-1
REAR PROTECTION ARMOR KIT .....	5 5-1
FRONT COWL PROTECTION ARMOR KIT .....	6 6-1
WINDSCREEN PROTECTION ARMOR KIT .....	7 7-1
ROOF PROTECTION ARMOR KIT .....	8 8-1
FOAM INSULATION KIT .....	9 9-1

GROUP 94 SPECIAL PURPOSE KITS

9401 KITS .....	KITS-1
NATIONAL STOCK NUMBER INDEX .....	I-1
PART NUMBER INDEX .....	I-3

Index .....	Index 1
-------------	---------

---

# HOW TO USE THIS TECHNICAL BULLETIN

## NOTE

If at any time you are unsure how to use this bulletin or you cannot locate the information you need, notify your supervisor.

## INTRODUCTION

1. This bulletin is designed to help you operate and maintain the M915A3P1, M915A2P1, M916A3P1, M917A2P1, M915A4P1, M917A1P1, M916A1P1, and M916A2P1 Crew Protection Kit. It also provides installation instructions for the Crew Protection Kit (CPK) and the Repair Parts and Special Tools Lists (RPSTL).
2. This bulletin is written in work package format:
  - a. Chapters divide the manual into major categories of information (e.g., *General Information, Equipment Description, and Theory of Operation; Operator Instructions; Operator Maintenance Instructions; Unit Maintenance Instructions; and Supporting Information*).
  - b. Each Chapter is divided into work packages, which are identified by a 6-digit number (e.g. 0001 00, 0002 00, etc.) located on the upper right-hand corner of each page. The work package page number (e.g. 0001 00-1, 0001 00-2, etc.) is located centered at the bottom of each page.
  - c. If a Change Package is issued to this bulletin, added work packages use the 5th and 6th digits of their number to indicate new material. For instance, work packages inserted between WP 0001 00 and WP 0002 00 are numbered WP 0001 01, WP 0001 02, etc.
3. Read through this bulletin to become familiar with its organization and contents before attempting to operate or maintain the armor kit.

## CONTENTS OF THIS BULLETIN

1. A *Warning Summary* is located at the beginning of this bulletin. Become familiar with these warnings before operating or performing maintenance on the armor kit.
2. A *Table of Contents*, located in the front of the bulletin, lists all chapters and work packages in the publication.
  - a. The Table of Contents also provides *Reporting Errors and Recommending Improvements* information and DA Form 2028 addresses, for the submittal of corrections to this bulletin.
  - b. If you cannot find what you are looking for in the Table of Contents, refer to the alphabetical *Index* at the back of the bulletin.
3. Chapter 1, *General Information, Equipment Description and Data, and Theory of Operation*, provides general information on the bulletin and the armor kit.
4. Chapter 2, *Operator Instructions*, explains and illustrates all operator procedures for the armor kit: *Operation Under Usual Conditions* and *Operation Under Unusual Conditions*.
5. Chapter 3, deals with *Operator Maintenance Instructions*. This chapter includes *Operator Preventive Maintenance Checks and Services (PMCS) Introduction* and *Operator Preventive Maintenance Checks and Services (PMCS)*.
6. Chapter 4, includes all maintenance tasks related to *Unit Maintenance Instructions*.
7. Chapter 5, includes *Supporting Information: References; Maintenance Allocation Chart (MAC) Introduction; Maintenance Allocation Chart (MAC); Expendable and Durable Items List; Tool Identification List; Torque Limits; Crew Protection Kit Installation Instructions; Repair Parts and Special Tools Lists (RPSTL) Introduction; and Repair Parts and Special Tools Lists (RPSTL)*.

### **WARNING**

A WARNING indicates a hazard which may cause injury or death to personnel.

### **CAUTION**

A CAUTION is a reminder of safety practices or directs attention to usage practices that may cause damage to equipment.

### **NOTE**

A NOTE is a statement containing information that will make the procedures easier to perform.

3. Statements and words of particular interest may be printed in CAPITAL LETTERS to create emphasis.
4. Within a procedural step, reference may be made to another work package in this bulletin or to another manual. These references indicate where you should look for more complete information.
  - a. If you are told: "Refer to *Crew Protection Kit Installation Instructions* (WP 0036 00)", go to WP 0036 00 in this bulletin for instructions on this procedure.
  - b. If you are told: "For complete information on M915A3P1 Operator PMCS, refer to TM 9-2320-302-10", go to *References* in WP 0031 00 for complete information on the cited reference.
5. Illustrations are placed after, and as close to, the procedural steps to which they apply. Callouts placed on the art are text or numbers.
6. Numbers located at lower right corner of art (e.g. 417-001; 417-002, etc.) are art control numbers and are used for tracking purposes only.
7. Technical instructions include metric units as well as standard units. For your reference, a *Metric Conversion Chart* is located on the inside back cover of the bulletin.





**CHAPTER 1**  
**GENERAL INFORMATION, EQUIPMENT**  
**DESCRIPTION AND DATA, AND THEORY OF OPERATION**



**SCOPE**

This technical bulletin is for your use in operating and performing Operator, Unit, and Direct Support Maintenance on the Crew Protection Kit installed on:

Truck, Tractor, M915A3P1, Line-Haul

Truck, Tractor, M915A2P1, Line-Haul

Truck, Tractor, M916A3P1, Light Equipment Transporter (LET)

Truck, Dump, M917A2P1, Heavy, Chassis

Truck, Tractor, M915A4P1, Line-Haul

Truck, Dump, M917A1P1, Heavy, Chassis

Truck, Tractor, M916A1P1, Light Equipment Transporter (LET)

Truck, Tractor, M916A2P1, and Light Equipment Transporter (LET)

This technical bulletin also covers armor kit installation instructions and the Repair Parts and Special Tools Lists (RPSTL) for the kit.

**MAINTENANCE FORMS, RECORDS, AND REPORTS**

Department of the Army forms and procedures used for the equipment will be those prescribed by DA PAM 750-8, *Functional Users Manual for The Army Maintenance Management System (TAMMS)*, as contained in the Maintenance Management Update.

**REPORTING EQUIPMENT IMPROVEMENT RECOMMENDATIONS (EIR)**

If your armor kit needs improvement, let us know. Send us an EIR. You, the user, are the only one who can tell us what you don't like about your equipment. Let us know why you don't like the design or performance. If you have Internet access, the easiest and fastest way to report problems or suggestions is to go to <https://aeps.ria.army.mil/aepspublic.cfm> (scroll down and choose the "Submit Quality Deficiency Report" bar). The Internet form lets you choose to submit an Equipment Improvement Recommendation (EIR), or a Product Quality Deficiency Report (PQDR). You may also submit your information using an SF Form 368 (*Product Quality Deficiency Report*). You can send your SF Form 368 via e-mail, regular mail, or facsimile using the addresses/facsimile numbers specified in DA PAM 750-8, *Functional Users Manual for The Army Maintenance Management System (TAMMS)*. We will send you a reply.

**CORROSION PREVENTION AND CONTROL (CPC)**

1. Corrosion Prevention and Control (CPC) of Army materiel is a continuing concern. It is important that any corrosion problems with this item be reported so that the problem can be corrected and improvements can be made to prevent the problem in future items.
2. While corrosion is typically associated with rusting of metals, it can also include deterioration of other materials, such as rubber and plastic. Unusual cracking, softening, swelling, or breaking of these materials may be a corrosion problem. If a corrosion problem is identified, it can be reported using SF Form 368 (*Product Quality Deficiency Report*). Use of key words such as "corrosion," "rust," "deterioration," or "cracking" will ensure that the information is identified as a CPC problem. The form should be submitted to the address specified in DA PAM 750-8.

**DESTRUCTION OF ARMY MATERIEL TO PREVENT ENEMY USE**

For destruction of Army material to prevent enemy use, refer to TM 750-244-6.

**PREPARATION FOR STORAGE OR SHIPMENT**

Refer to TM 9-2320-302-20 for the following vehicles:

- Truck, Tractor, M915A3P1, Line-Haul
- Truck, Tractor, M916A3P1, Light Equipment Transporter (LET)
- Truck, Dump, M917A2P1, Heavy, Chassis

Refer to TM 9-2320-303-24 for the following vehicles:

- Truck, M915A4P1, Tractor, Line-Haul

Refer to TM 9-2320-363-20 for the following vehicles:

- Truck, Tractor, M915A2P1, Line-Haul
- Truck, Tractor, M916A1P1, Light Equipment Transporter (LET)
- Truck, Tractor, M916A2P1, and Light Equipment Transporter (LET)
- Truck, Dump, M917A1P1, Heavy, Chassis

**LIST OF ABBREVIATIONS/ACRONYMS**

**NOTE**

Refer to ASME Y14.38-1999 for standard abbreviations.

**ABBREVIATIONS/ACRONYMS**

**DEFINITION**

cm	Centimeter
CPK	Crew Protection Kit
IAW	In Accordance With
kg	Kilogram
lb-ft	Pound Foot
lb-in.	Pound Inch
mm	Millimeter
Nm	Newton Meter
PMCS	Preventive Maintenance Checks and Services
P/N	Part Number

**QUALITY OF MATERIAL**

Material used for replacement, repair, or modification of the Crew Protection Kit must meet the requirements of this technical bulletin. If quality of material requirements are not stated in this technical bulletin, the material must meet the requirements of the drawings, standards, specifications, or approved engineering change proposals applicable to the Crew Protection Kit.

**SAFETY, CARE, AND HANDLING**

Follow procedures, warnings, and cautions as written in this technical bulletin.

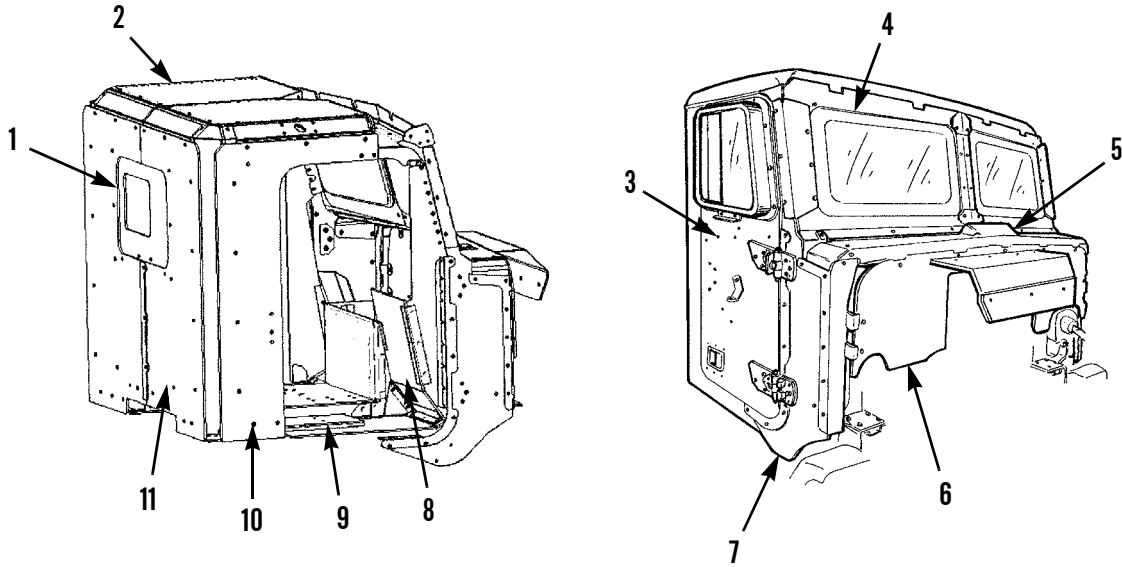
**END OF WORK PACKAGE**

***EQUIPMENT CHARACTERISTICS, CAPABILITIES, AND FEATURES***

1. The Crew Protection Kit provides improved protection for the following vehicles:
  - a. Truck, Tractor, M915A3P1, Line-Haul
  - b. Truck, Tractor, M915A2P1, Line-Haul
  - c. Truck, Tractor, M916A3P1, Light Equipment Transporter (LET)
  - d. Truck, Dump, M917A2P1, Heavy, Chassis
  - e. Truck, Tractor, M915A4P1, Line-Haul
  - f. Truck, Dump, M917A1P1, Heavy, Chassis
  - g. Truck, Tractor, M916A1P1, Light Equipment Transporter (LET)
  - h. Truck, Tractor, M916A2P1, Light Equipment Transporter (LET)
2. The Crew Protection Kit consists of the following:
  - a. Driver-side, floor, and passenger-side armor
  - b. Front, cowl, firewall, rear, and roof armor panels
  - c. Door assemblies
  - d. Ballistic glass for windshield and side door windows
  - e. Escape hatch
  - f. Foam Insulation

**LOCATION AND DESCRIPTION OF MAJOR COMPONENTS**

The illustration below shows major armor kit components and their location in relation to the cab.



417-150

KEY	COMPONENT
1	Escape Hatch
2	Roof Armor
3	Door Assembly
4	Windshield Frame and Windshield Ballistic Glass
5	Cowl Armor
6	Front Armor
7	Side (Front) Armor
8	Firewall Armor
9	Floor Armor
10	Side (Rear) Armor
11	Rear Armor

**END OF WORK PACKAGE**

**GENERAL**

The Crew Protection Kit consists of two armored doors, roof armor, windshield ballistic glass, floor armor, firewall armor, forward and rear side armor panels, rear cab armor panels, an armored access cover (front), and an armored escape hatch.

The front side armor assembly consists of an armor panel that is mounted to the existing door frame and is bolted in place of original door hinge. The armored door assembly (which incorporates sliding ballistic glass) is bolted to the front side armor assembly.

There are three floor armor panels that are attached to each other using brackets and grade 8 bolts. Rear armor panels rest on the floor armor panels and are supported by corner brackets on right and left side. The roof armor panel is supported by rear armor panels, side armor, and corner brackets.

The remaining armor panels are fastened to the vehicle using attachment brackets and grade 8 hardware.

**Table 1. M915A2 Front Suspension Kit (Part Number: 57K4954)  
TM Reference - TM 9-2320-363-20.**

QTY	PART NUMBER	NSN	PART DESCRIPTION
2	A16-11814-001	2510-01-537-5820	14,000 lb Flat Leaf Suspension Spring, 4"
4	11-09624-095	5306-01-327-6409	U Bolt-Suspension, 7/8-14 X 9.5 inch long
8	16-09040-002	2510-01-326-9147	Wear Plate-Spring Pin, Shackle
2	16-11905-xxx		Spacer, Axle Stop to Spring, 1.25 X 4.0 X 6.0 in.
6	16-12373-000	3040-01-327-0143	Pin-Spring
8	23-00461-007	5310-01-343-1030	Nut-Hex, 7/8-14
24	23-09114-003	5310-00-767-9425	Washer-Hardened, 1/2 inch nominal ID
8	23-09114-005	5310-00-584-7796	Washer-Hardened, 7/8 inch nominal ID
8	23-09114-009	5310-01-329-7043	Washer-Hardened, 1 1/8 inch nominal ID, 1.25"
8	23-09440-250	5305-00-616-6375	Screw-Cap, Hex, 1/2-13 X 2.5" long, Grade 8
8	23-09440-325	5305-01-139-7071	Screw-Cap, Hex, 1/2-13 X 3.25" long, Grade 8
16	23-09860-012		Washer-Flat, 1.25 x 1.88 X 0.031 inch
8	23-13175-108		Nut-Hex, 1/2-13
6	23-13275-000		Fitting, Lubrication, 90 degree Elbow
2	16-13363-011	5365-01-356-8951	Shim-Axle, 3.0 degree, 4.0 inch
2	23-09271-138	5315-01-327-5977	Pin-Dowel, .75" OD X 1.38" long

## GENERAL - CONTINUED

**Table 2. M915A3 Front Suspension Kit (Part Number: 57K4955)**  
**TM Reference - TM 9-2320-302-20.**

QTY	PART NUMBER	NSN	PART DESCRIPTION
1	1-4854		Data Plate
1	M915A2		14K Susp Installn Instructions
NA	620-C03409		GVG-FR 14.6K SUSP
2	A16-12614-001	2510-01-533-2169	SPRG-14.6K TPR,4,USF,GBRZ
REF	D16-16555-001		INST-SUSP,14.6K,FRT,M915 LHS
2	11-09624-100	5306-01-327-5536	U BOLT-SUSP,7/8-14,494,1000
2	11-09624-095	5306-01-327-6409	U BOLT-SUSP,7/8-14,494,9.50
1	16-10386-003	5365-01-329-1141	SPCR-AXLE,1.00,575X400,.766OD
1	16-10386-004		SPCR-AXLE,1.25,575X400,.766OD
1	23-09271-238	5315-01-502-8292	PIN-DOWEL,.75 OD X 2.38 LG
1	23-09271-262	3120-01-481-3166	PIN-DOWEL,.75 OD X 2.62 LG
8	23-09440-325	5305-01-139-7071	SCREW-CAP,HEX1/2-13X3.25 GR8PO
8	23-09114-005	5310-00-584-7796	Washer-Hardened, 7/8 inch nominal ID
8	23-00461-007	5310-01-343-1030	Nut-Hex, 7/8-14
24	23-09114-003	5310-00-767-9425	Washer-Hardened, 1/2 inch nominal ID
12	23-13175-108		Nut-Hex, 1/2-13
16	23-09860-012		Washer-Flat, 1.25 x 1.88 X 0.031 inch
8	16-09040-002	2510-01-326-9147	Wear Plate-Spring Pin, Shackle
6	16-12373-000	3040-01-327-0143	Pin-Spring
6	23-13275-000		Fitting, Lubrication, 90 degree Elbow
2	16-13363-011	5365-01-356-8951	Shim-Axle, 3.0 degree, 4.0 inch
8	23-09114-009	5310-01-329-7043	Washer-Hardened,1 1/8 inch nominal ID, 1.25" actual ID
4	23-09440-400		Screw-Cap, Hex, 1/2-13 x 4.0" long, Grade 8
1	1-4855		Data Plate



## GENERAL - CONTINUED

**Table 3. M915A4 Front Suspension Kit (Part Number: 57K4956)**  
**TM Reference -TM 9-2320-303-24.**

QTY	PART NUMBER	NSN	PART DESCRIPTION
1	M915A3		14K Susp Installn Instructions
2	A16-11814-001	2510-01-537-5820	14,000 lb Flat Leaf Suspension Spring, 4"
4	11-09624-120	5306-01-528-2142	U Bolt-Suspension, 7/8-14 X 12.0 inch long
8	16-09040-002	2510-01-326-9147	Wear Plate-Spring Pin, Shackle
2	16-10386-013	5365-01-531-2112	Spacer, Axle Stop to Spring
6	16-12373-000	3040-01-327-0143	Pin-Spring
8	23-00461-007	5310-01-343-1030	Nut-Hex, 7/8-14
24	23-09114-003	5310-00-767-9425	Washer-Hardened, 1/2 inch nominal ID
8	23-09114-005	5310-00-584-7796	Washer-Hardened, 7/8 inch nominal ID
8	23-09114-009	5310-01-329-7043	Washer-Hardened, 1 1/8 inch nominal ID, 1.25"
8	23-09440-250	5305-00-616-6375	Screw-Cap, Hex, 1/2-13 X 2.5" long, Grade 8
8	23-09440-325	5305-01-139-7071	Screw-Cap, Hex, 1/2-13 X 3.25" long, Grade 8
16	23-09860-012		Washer-Flat, 1.25 x 1.88 X 0.031 inch
8	23-13175-108		Nut-Hex, 1/2-13
6	23-13275-000		Fitting, Lubrication, 90 degree Elbow
2	16-13363-011	5365-01-356-8951	Shim-Axle, 3.0 degree, 4.0 inch
2	23-09271-338	5315-01-527-9244	Pin-Dowel, .75" OD X 3.88" long
1	1-4856		Data Plate
1	M915A4		14K Susp Install Instructions

END OF WORK PACKAGE



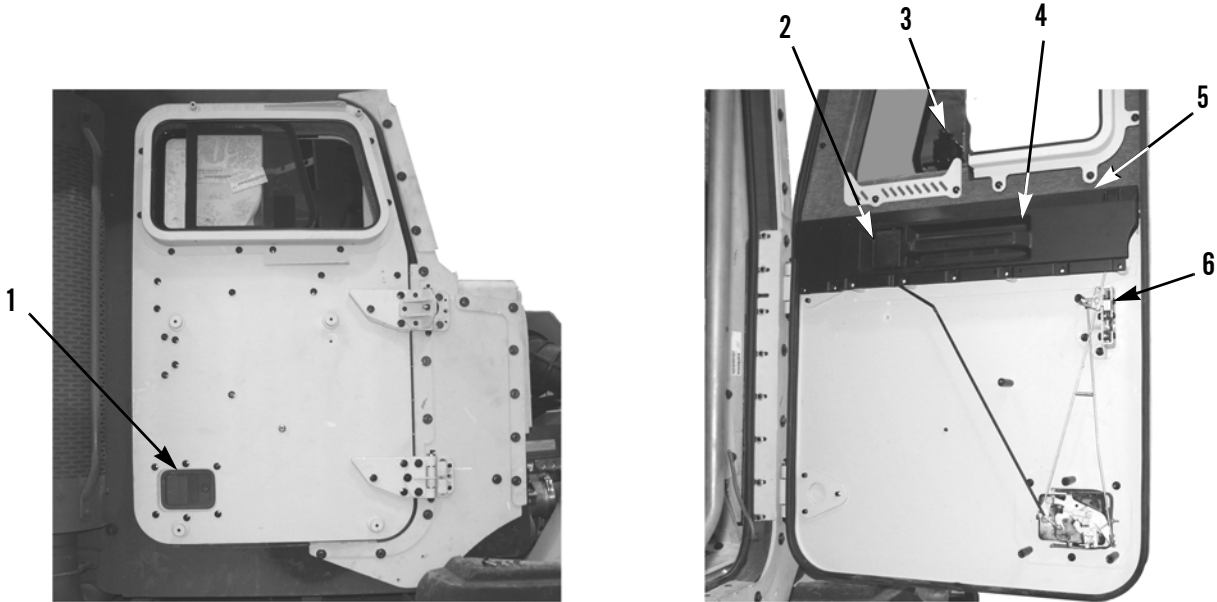
**CHAPTER 2**  
**OPERATOR INSTRUCTIONS**



**GENERAL**

1. This work package describes all operator controls for the Crew Protection Kit.
2. Do not attempt to operate the vehicle with Crew Protection Kit installed until becoming familiar with the location and function of all armor kit controls.

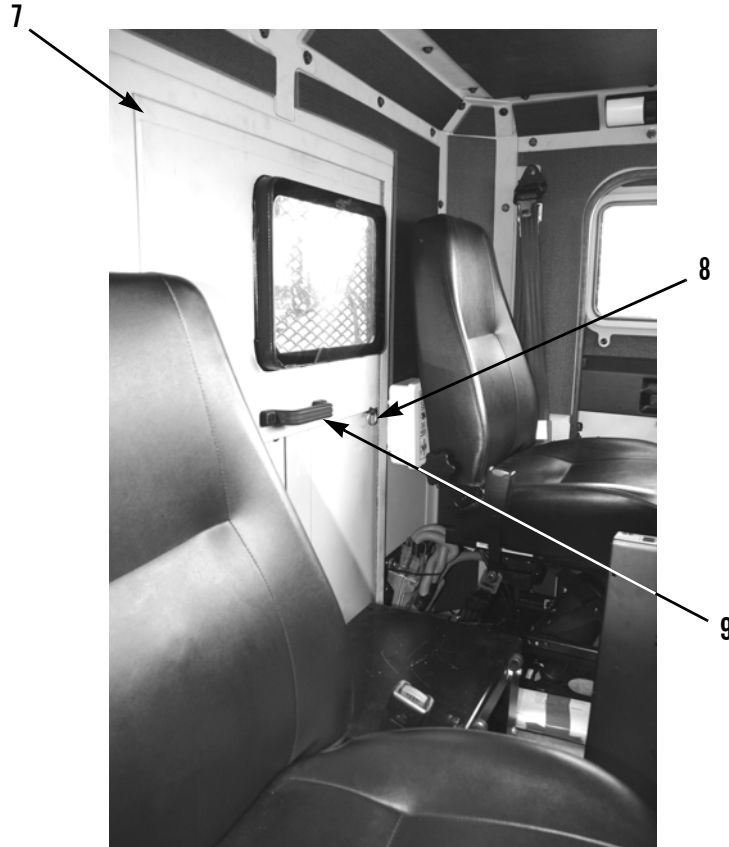
**OPERATOR CONTROLS AND INDICATORS**



417-263

KEY	CONTROL OR INDICATOR	FUNCTION
1	Exterior Door Handle	Allows driver or passenger side door to be opened from outside cab.
2	Interior Door Handle	Allows driver or passenger side door to be opened from inside cab.
3	Window Latch	Allows driver or passenger side window to be opened from inside cab.
4	Grab Handle	Provides hand hold on inside of door.
5	Lock	Secures door from opening by pushing down lock from inside cab or outside cab by using door lock key. Unlocked inside the cab by pulling up lock button and outside by using door lock key.
6	Latch	Secures side door closed.

OPERATOR CONTROLS AND INDICATORS - CONTINUED



417-298

KEY	CONTROL OR INDICATOR	FUNCTION
7	Escape Hatch	Provides an alternate exit from cab. Refer to WP 0006 00.
8	Release Pins	Secures escape hatch in closed position. Remove two pins to open escape hatch. Refer to WP 0006 00.
9	Grab Handle	Provides a hand hold when opening or closing escape hatch.

END OF WORK PACKAGE

**GENERAL**

1. This work package contains instructions for safely operating the following vehicles with CPK installed:
  - Truck, Tractor, M915A3P1, Line-Haul
  - Truck, Tractor, M915A2P1, Line-Haul
  - Truck, Tractor, M916A3P1, Light Equipment Transporter (LET)
  - Truck, Dump, M917A2P1, Heavy, Chassis
  - Truck, Tractor, M915A4P1, Line-Haul
  - Truck, Dump, M917A1P1, Heavy, Chassis
  - Truck, Tractor, M916A1P1, Light Equipment Transporter (LET)
  - Truck, Tractor, M916A2P1, and Light Equipment Transporter (LET)
2. Before operating vehicle with CPK read and follow the procedures in *Operation Under Usual Conditions* in Operator Technical Manual for specific vehicle. Refer to *References* (WP 0031 00) for more information on sited reference.

**INITIAL ADJUSTMENTS AND DAILY CHECKS****NOTE**

Refer to WP 0004 00 for the location and operation of operator controls.

Perform *Before* operation Preventive Maintenance Checks and Services (PMCS) before operation (WP 0008 00 and WP 0009 00).

**OPERATING VEHICLE****WARNING**

Due to increased weight with CPK installed, operator should be aware of differences in vehicle's driving characteristics and adjust driving accordingly. Failure to do so may cause injury or death to personnel.

1. With CPK installed, vehicle is heavier than usual. Due to this increased weight, adjust driving to allow for greater stopping distance.
2. Vehicle may steer differently with CPK installed. Adjust vehicle speed accordingly and exercise caution.

**WARNING**

- The center of gravity is higher on a vehicle with a Crew Protection Kit installed.
  - Always use slower speed when operating vehicle.
  - DO NOT operate vehicle on steep hills or inclines.
  - Failure to follow these warnings may cause injury or death to personnel.
3. The center of gravity is higher with a Crew Protection Kit installed. Use slower speeds when making turns or changing lanes. Also, use extreme caution when operating the vehicle on any incline. The higher center of gravity increases the chance of rollover.

**WARNING**

Visibility is reduced on a vehicle with a Crew Protection Kit installed. Always use ground guides when maneuvering vehicle near obstacles. Failure to follow this warning may cause injury to personnel or damage to equipment.

4. Visibility is reduced with a Crew Protection Kit installed. Operate vehicle with caution and use ground guides.

**OPERATING VEHICLE - CONTINUED****WARNING**

Vehicles with a Crew Protection Kit installed have different door handles and latching hardware. Do not allow clothing or equipment to catch on door hardware. Failure to follow this warning may cause injury to personnel.

5. When entering or exiting the vehicle, use three-point contact procedure at all times. Keep clothing and equipment away from door hardware.

**WARNING**

DO NOT park vehicle on a hill or incline. The parking brake has a reduced capacity due to the increased weight of vehicle with Crew Protection Kit installed. Failure to follow this warning may cause injury or death to personnel.

6. Park vehicle on level surface.
7. Operate heater/air conditioning system as needed to ensure proper cab ventilation as in Operator Technical Manual for specific vehicle. Refer to *References* (WP 0031 00) for more information on sited reference.
8. Maintain good visibility for operating personnel. Keep all ballistic glass clean. Follow cleaning instructions in *Cleaning Ballistic Glass* (WP 0010 00).

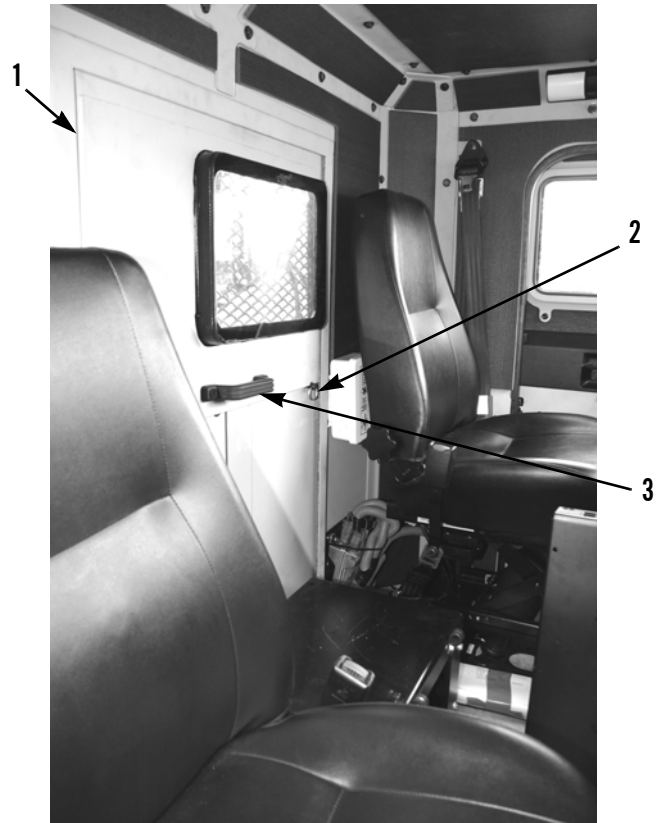
**END OF WORK PACKAGE**



Before operating vehicle with CPK read and follow the procedures in *Operation Under Unusual Conditions* in Operator Technical Manual for specific vehicle. Refer to *References* (WP 0031 00) for more information on sited reference.

### **ESCAPE HATCH OPERATION**

1. Pull two escape hatch pins (2) and use grab handle (3) to open escape hatch (1).

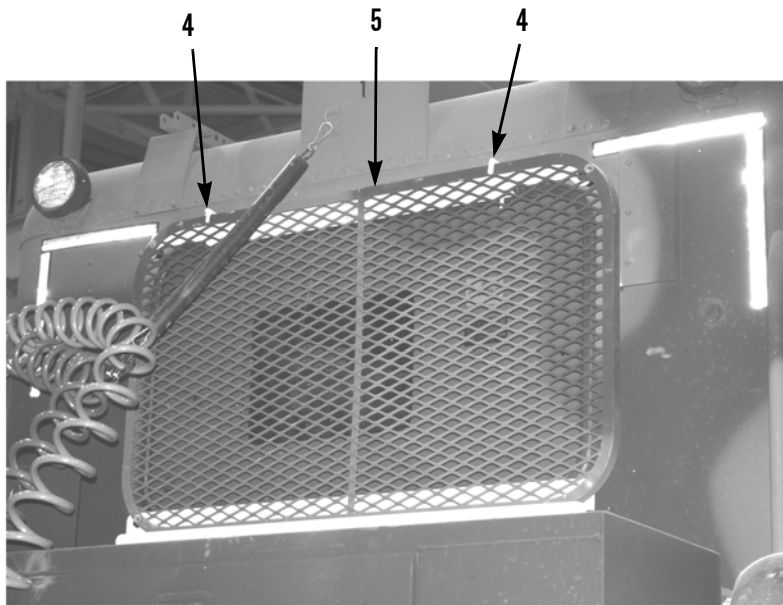


417-298

**ESCAPE HATCH OPERATION - CONTINUED****NOTE**

Clips on rear window grate are of break-away type. It may be necessary to install new clips when grate is pushed open from inside cab.

- Remove rear window grate (5) by pushing outward to release clips (4).



417-265

- Exit vehicle through rear window.

**OPERATION IN EXTREME TEMPERATURES**

Operation in extreme temperatures with a Crew Protection Kit installed requires altering operating procedures.

**Extreme Cold****CAUTION**

Never use scraper to remove frost or ice from ballistic glass. Failure to follow this caution will damage outer layer.

**NOTE**

Clearing frost from ballistic glass requires more time than standard glass.

Extend vehicle warm-up time and operate heater and defroster to clear frost from ballistic glass as in Operator Technical Manual for specific vehicle. Refer to *References* (WP 0031 00) for more information on sited reference.

**Extreme Heat****NOTE**

The Crew Protection Kit absorbs and retains more heat than a standard cab.

- Park vehicle away from direct sunlight whenever possible.
- Operate air conditioner to cool down interior of cab as in Operator Technical Manual for specific vehicle. Refer to *References* (WP 0031 00) for more information on sited reference.

**END OF WORK PACKAGE**

---

**STOWAGE AND DECAL/DATA PLATE GUIDE**

---

**0007 00**

**GENERAL**

1. There is no stowage guide related to the Crew Protection Kit. Refer to Operator Technical Manual for specific vehicle. Refer to *References* (WP 0031 00) for more information on sited reference.
2. For information on decals and data plates refer to Operators Technical Manual for specific vehicle. Refer to *References* (WP 0031 00) for more information on sited reference.

**END OF WORK PACKAGE**



**CHAPTER 3**  
**OPERATOR MAINTENANCE INSTRUCTIONS**



**GENERAL****NOTE**

- Information in this PMCS Introduction applies only to preventive maintenance checks and services for the Crew Protection Kit.
  - For vehicle specific information, refer to the PMCS introduction in Operator Technical Manual for specific vehicle. Refer to *References* (WP 0031 00) for more information on sited reference.
1. To ensure that the Crew Protection Kit is ready for operation at all times, it must be inspected on a regular basis so that defects may be found and corrected before they result in injury or death due to equipment failure.
  2. The PMCS Table in WP 0009 00 contains systematic instructions on inspections and services to be performed by the operator to keep your equipment in good operating condition and ready for its primary mission.

**EXPLANATION OF TABLE ENTRIES**

1. **Item Number (Item No.) Column.** Numbers in this column are for reference. When completing DA Form 2404 or DA Form 5988-E (*Equipment Inspection and Maintenance Worksheet*), include the item number for the check/service indicating a fault. Item numbers also appear in the order that you must perform checks and services for the interval listed.
2. **Interval Column.** This column tells you when you must perform the procedure in the procedure column.
  - a. *Before* procedures must be done immediately before you operate vehicle with Crew Protection Kit installed.
  - b. *After* procedures must be done immediately after operating vehicle with Crew Protection Kit installed.
  - c. *Weekly* procedures must be done once each week.
3. **Location, Item to Check/Service Column.** This column provides the location and item to be checked or serviced.

**NOTE**

The WARNINGS and CAUTIONS appearing in your PMCS table should always be observed. WARNINGS and CAUTIONS appear before applicable procedures. You must observe these WARNINGS to prevent injury or death to personnel, and CAUTIONS to prevent your equipment from being damaged.

4. **Procedure Column.** This column gives the procedure you must perform to check or service the item listed in the Item to Check/Service column, to know if the equipment is ready or available for its intended mission. You must perform the procedure at the time stated in the interval column.
5. **Not Fully Mission Capable If: Column.** Information in this column tells you what faults will keep your equipment from being capable of performing its primary mission. If you perform check/service procedures that show faults listed in this column, the equipment is not mission-capable. Follow standard operating procedures for maintaining the equipment or reporting equipment failure.

**GENERAL PMCS PROCEDURES**

1. Always perform PMCS in the same order so it gets to be a habit. Once you've had some practice, you'll spot anything wrong in a hurry.
2. If anything looks wrong and you can't fix it, write it on your DA Form 2404 or DA Form 5988-E. If you find something seriously wrong, IMMEDIATELY report it to your supervisor.
3. Before performing preventive maintenance, read all the checks required for the applicable interval and prepare all that is needed to make all the checks. You'll always need a rag (Item 6, WP 0034 00) or two.

---

**OPERATOR PREVENTIVE MAINTENANCE CHECKS AND SERVICES (PMCS)  
INTRODUCTION - CONTINUED**


---

0008 00

**GENERAL PMCS PROCEDURES - CONTINUED****WARNING**

Solvent cleaning compound MIL-PRF-680 Type III is an environmentally compliant and low toxic material. However, it may be irritating to the eyes and skin. Use protective gloves and goggles. Use in well-ventilated areas. Keep away from open flames and other sources of ignition.

- a. **Keep It Clean.** Dirt, grease, oil, and debris get in the way and may cover up a serious problem. Clean as you work and as needed. Use solvent cleaning compound (Item 2, WP 0034 00) on all metal surfaces. Use detergent (Item 4, WP 0034 00) and water when you clean rubber, plastic, and painted surfaces.

**WARNING**

When servicing this machine, performing maintenance or disposing of materials such as engine coolant, hydraulic fluid, lubricants, battery acids or batteries and CARC paint, consult your unit/local hazardous waste disposal center or safety office for local regulatory guidance. If further information is needed, please contact The Army Environmental Hotline at 1-800-872-3845.

- b. **Hazardous Waste Disposal.** Ensure all spills are cleaned up and disposed of IAW local policy and ordinances.
- c. **Rust and Corrosion.** Check metal parts for rust and corrosion. If any bare metal or corrosion exists, clean and apply a light coat of lubricating oil (Item 5, WP 0034 00). Report it to your supervisor.
- d. **Bolts, Nuts and Screws.** Check bolts, nuts, and screws for obvious looseness, missing, bent, or broken condition. If you find one is loose, notify your supervisor.
- e. **Electric Wires and Connectors.** Look for cracked or broken insulation, bare wires, and loose or broken connectors. Reconnect loose connectors. Ensure that wires are in good condition.

**CAUTION**

- Remove rings or other hard objects from hands before cleaning ballistic glass. **DO NOT** use hard, dirty or gritty cloths on ballistic glass. **DO NOT** apply water or detergent unless ballistic glass is cool and is protected from heating effects of sunlight. Failure to follow these instructions will damage ballistic glass.
  - **DO NOT** use bug spray or other aerosol sprays on or near ballistic glass. Failure to follow these instructions will damage ballistic glass.
- f. **Ballistic Glass.** Keep ballistic glass clean (WP 0010 00).
4. **Inspection Procedures and Replacement Criteria for Armor and Ballistic Glass.**
- a. **Metallic Armor.** Inspect for and replace the armor if any of the following conditions exist:
- (1) Stage 3 rust spots are areas of corrosion which may indicate a rusted through condition; (i.e. metal in corroded area is unsound and small pin holes are present).
  - (2) Stage 4 rust is a rust through condition.
  - (3) User modifications that have not been authorized by the Vehicle PM.



---

**OPERATOR PREVENTIVE MAINTENANCE CHECKS AND SERVICES (PMCS)  
INTRODUCTION - CONTINUED**

---

0008 00

**GENERAL PMCS PROCEDURES - CONTINUED**

- (4) Examine areas around bolts and bolt holes for cracks or elongation of the holes. Cracks that are 1 inch or longer, or 2 consecutive bolt holes elongated are cause to replace the armor panel.
- (5) Look for signs that the armor has been deformed or damaged, including:
  - (a) Armor that is dented or bent out of shape.
  - (b) Bent door frames and door support posts which won't allow the doors to close properly.
  - (c) Bent, warped, or misaligned body panels that cause gaps between adjacent armor panels.
  - (d) Any complete penetration of the armor (a hole in the armor) or multiple gouges 1/4 inch or deeper within 3 inches of each other.
- b. **Ceramic/Composite Armor.** Inspect for and replace if there is any visible damage.
- c. **Transparent Armor (Ballistic Glass).** Inspect transparent armor for damage and replace if any of the following conditions exist:
  - (1) Cloudiness in the glass which interfere with the driver's vision.
  - (2) Rock chips, cracks with spider webbing, decals, or stickers that impair vision.
  - (3) Any hit that exposes the glass below the first layer.

**END OF WORK PACKAGE**



Item No.	Interval	Location	Procedure	Not Fully Mission Capable If:
		Item To Check/Service		
			<p><b>NOTE</b></p> <ul style="list-style-type: none"> <li>• Perform PMCS in Operator Technical Manual for specific vehicle BEFORE performing PMCS for the Crew Protection Kit. Refer to <i>References</i> (WP 0031 00) for more information on sited reference.</li> <li>• Review all WARNINGS, CAUTIONs, and NOTEs before performing PMCS and operating vehicle.</li> <li>• Perform all PMCS checks if:                             <ol style="list-style-type: none"> <li>a. You are the assigned operator but have not operated the vehicle with armor kit since the last weekly checks.</li> <li>b. You are operating the vehicle with armor kit for the first time.</li> </ol> </li> <li>• Perform PMCS with vehicle parked on level ground, parking brake applied, transmission in N (Neutral), wheels blocked, and engine shut down.</li> </ul>	

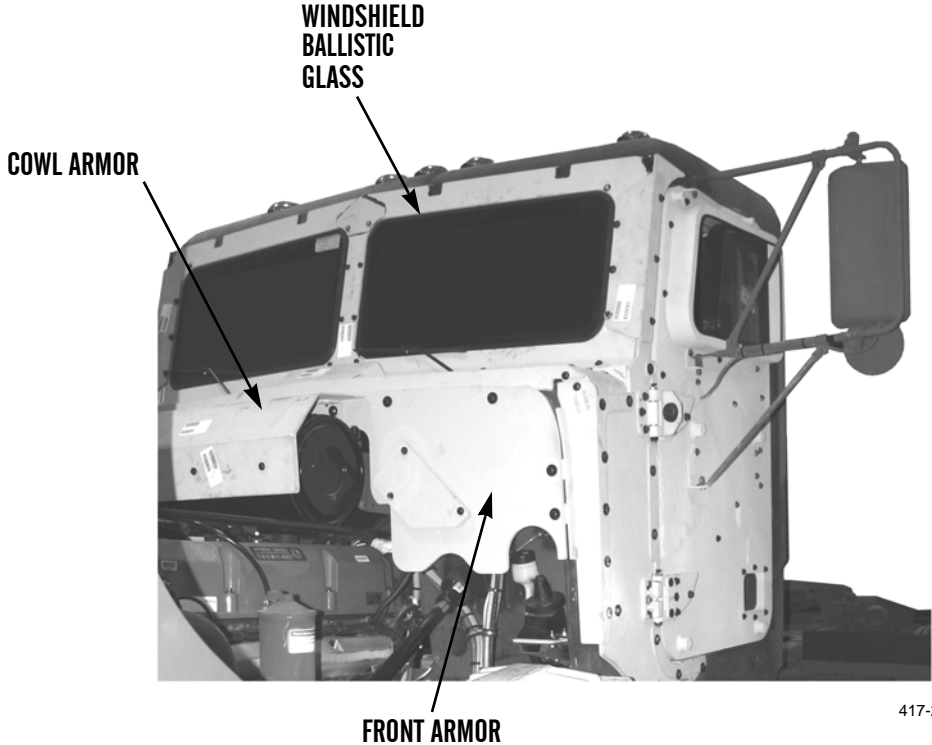
OPERATOR PREVENTIVE MAINTENANCE CHECKS AND SERVICES (PMCS) - CONTINUED

0009 00

Item No.	Interval	Location	Procedure	Not Fully Mission Capable If:
		Item To Check/ Service		
1	Before	<b>FRONT AND LEFT SIDE</b>	a. Inspect front and cowl armor panels for damage or loose or missing mounting hardware. b. Inspect front and cowl armor panels for areas of rust or corrosion. c. Inspect front and cowl armor panels for cracks near or elongation of bolt holes. d. Inspect front and cowl armor panels for any holes or gouges. e. Inspect windshield ballistic glass mounting hardware for damage, loose, or missing mounting hardware. f. Inspect exterior surface of windshield ballistic glass for rock chips, cracks, scratches, pitting, any hits that expose glass below the first layer, cloudiness, or any stickers that impair vision. g. If dirty, clean windshield ballistic glass (WP 0010 00).	Any panel or armor plate is damaged, bent out of shape, misaligned, loose or missing, or mounting bolts are loose or missing. Any corrosion where area is unsound and small pin holes are present, or a rusted through condition is present. Any cracks that are longer than 1" or two consecutive bolt holes that are elongated. Any complete penetration of the armor (hole in the armor) or multiple gouges 1/4" or deeper within 3" of each other. Any ballistic glass mounting hardware is damaged, loose, or missing, or mounting bolts are loose or missing. Rock chips, cracks with spider webbing, scratches, pitting, or hits in the exterior layer of ballistic glass that expose glass below the first layer, cloudiness that impairs vision.
		<b>Front Armor</b>		

OPERATOR PREVENTIVE MAINTENANCE CHECKS AND SERVICES (PMCS) - CONTINUED

0009 00

Item No.	Interval	Location	Procedure	Not Fully Mission Capable If:
		Item To Check/ Service		
1 (Con't)	Before	Front Armor		

OPERATOR PREVENTIVE MAINTENANCE CHECKS AND SERVICES (PMCS) - CONTINUED

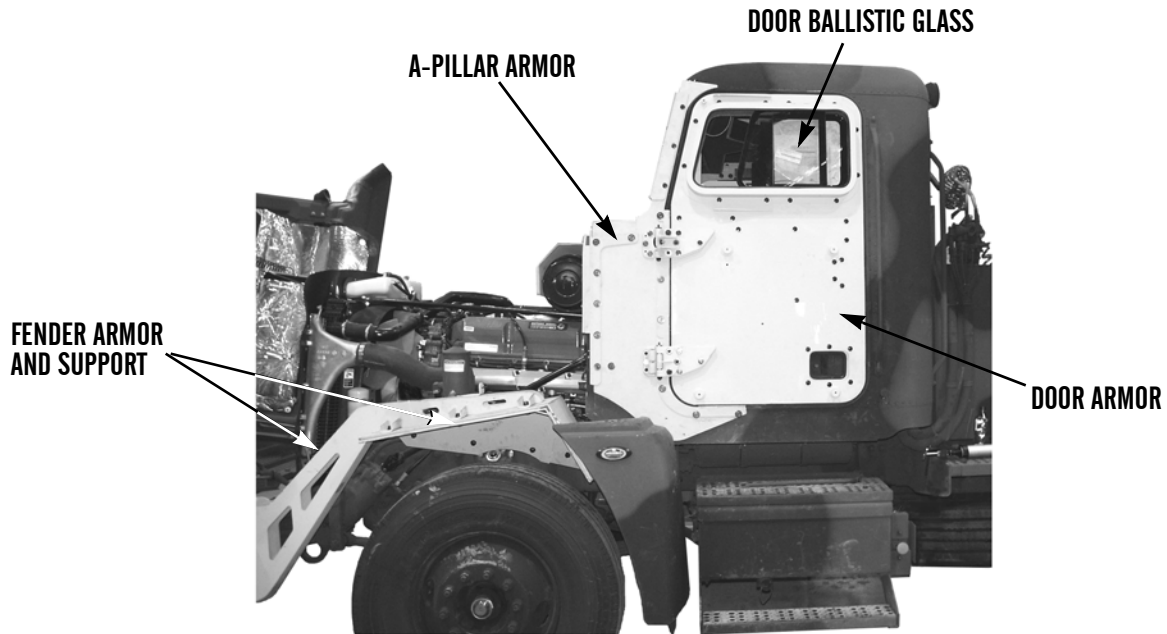
0009 00

Item No.	Interval	Location	Procedure	Not Fully Mission Capable If:
		Item To Check/Service		
2	Before	Side Armor (Left Side)	<p>a. Inspect A-pillar armor panels for damage or loose or missing mounting hardware.</p> <p>b. Inspect A-pillar armor panels for areas of rust or corrosion.</p> <p>c. Inspect A-pillar armor panels for cracks near or elongation of bolt holes.</p> <p>d. Inspect A-pillar armor panels for any holes or gouges.</p> <p>e. Inspect door ballistic glass mounting hardware for damage, loose, or missing mounting hardware.</p> <p>f. Inspect exterior surface of door ballistic glass for rock chips, cracks, scratches, pitting, any hits that expose glass below the first layer, cloudiness, or any stickers that impair vision.</p> <p>g. Inspect fender armor and support for damage or loose or missing mounting hardware.</p> <p>h. Inspect fender armor and support for areas of rust or corrosion.</p> <p>i. Inspect fender armor and support for cracks near or elongation of bolt holes.</p> <p>j. Inspect fender armor and support for any holes or gouges.</p> <p>k. Open door and enter cab. Close door using grab handle. Make sure door closes without binding and locks correctly (WP 0004 00).</p> <p>l. Make sure door ballistic glass can open, close, and securely lock.</p>	<p>Any panel or armor plate is damaged, bent out of shape, misaligned, loose or missing, or mounting bolts are loose or missing.</p> <p>Any corrosion where area is unsound and small pin holes are present, or a rusted through condition is present.</p> <p>Any cracks that are longer than 1" or two consecutive bolt holes that are elongated.</p> <p>Any complete penetration of the armor (hole in the armor) or multiple gouges 1/4" or deeper within 3" of each other.</p> <p>Any ballistic glass mounting hardware is damaged, loose, or missing, or mounting bolts are loose or missing.</p> <p>Rock chips, cracks with spider webbing, scratches, pitting, or hits in the exterior layer of ballistic glass that expose glass below the first layer, cloudiness that impairs vision.</p> <p>Any panel or armor plate is damaged, bent out of shape, misaligned, loose or missing, or mounting bolts are loose or missing.</p> <p>Any corrosion where area is unsound and small pin holes are present, or a rusted through condition is present.</p> <p>Any cracks that are longer than 1" or two consecutive bolt holes that are elongated.</p> <p>Any complete penetration of the armor (hole in the armor) or multiple gouges 1/4" or deeper within 3" of each other.</p> <p>Door binds or does not lock.</p> <p>Door ballistic glass will not close or lock.</p>

OPERATOR PREVENTIVE MAINTENANCE CHECKS AND SERVICES (PMCS) - CONTINUED

0009 00

Item No.	Interval	Location	Procedure	Not Fully Mission Capable If:
		Item To Check/Service		
2 (Con't)	Before	Side Armor (Left Side)	<p>m. Inspect interior surface of door ballistic glass and windshield ballistic glass for rock chips, cracks, scratches, pitting, any hits that expose glass below the first layer, cloudiness, or any stickers that impair vision.</p> <p>n. If dirty, clean ballistic glass (WP 0010 00).</p>	Rock chips, cracks with spider webbing, scratches, pitting, or hits in the exterior layer of ballistic glass that expose glass below the first layer, cloudiness that impairs vision.

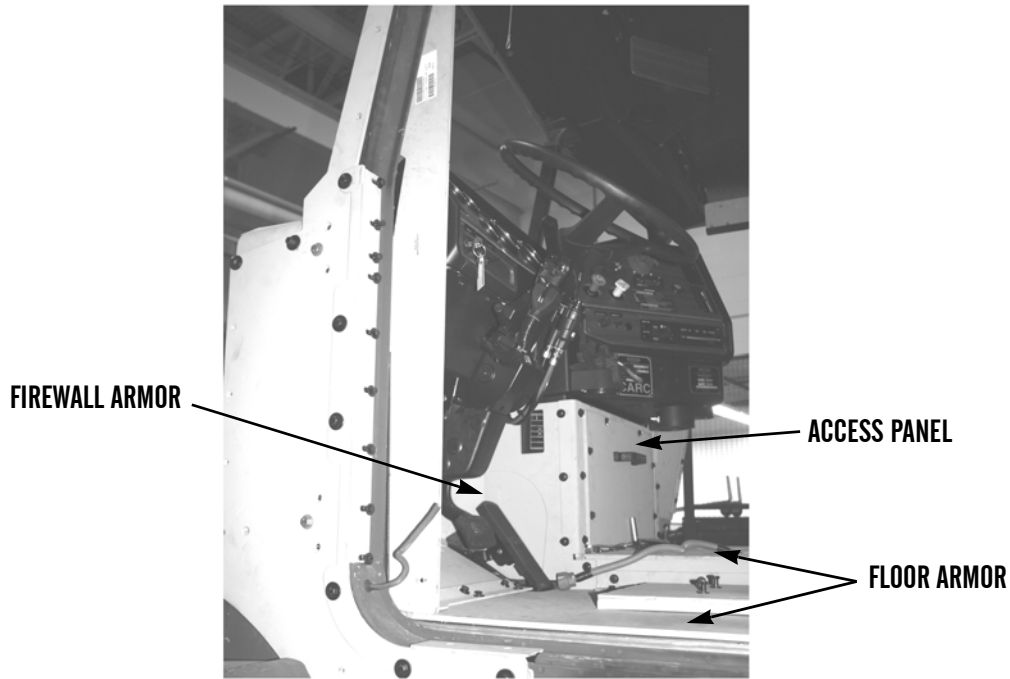


417-267

OPERATOR PREVENTIVE MAINTENANCE CHECKS AND SERVICES (PMCS) - CONTINUED

0009 00

Item No.	Interval	Location	Procedure	Not Fully Mission Capable If:
		Item To Check/Service		
3	Before	Floor /Fire-wall Armor (Left Side)	<p>a. Inspect left side floor and firewall armor panels for damage or loose or missing mounting hardware.</p> <p>b. Inspect left side floor and firewall panels for areas of rust or corrosion.</p> <p>c. Inspect left side floor and firewall armor panels for cracks near or elongation of bolt holes.</p> <p>d. Inspect left side floor and firewall armor panels for any holes or gouges.</p> <p>e. Inspect fuse access panel and support for damaged, loose, or missing mounting hardware.</p>	<p>Any panel or armor plate is damaged, bent out of shape, misaligned, loose or missing, or mounting bolts are loose or missing.</p> <p>Any corrosion where area is unsound and small pin holes are present, or a rusted through condition is present.</p> <p>Any cracks that are longer than 1" or two consecutive bolt holes that are elongated.</p> <p>Any complete penetration of the armor (hole in the armor) or multiple gouges 1/4" or deeper within 3" of each other.</p> <p>Any damaged to access panel or mounting hardware is loose or missing.</p>

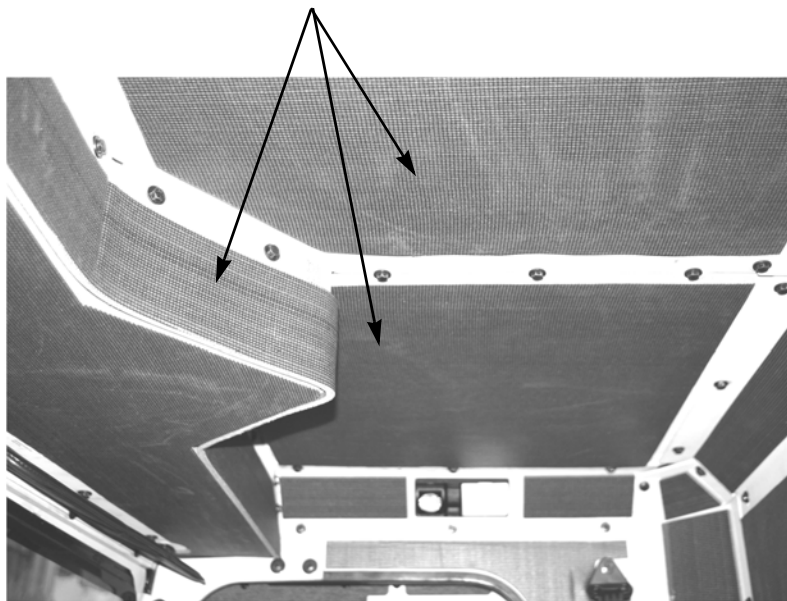


417-268



Item No.	Interval	Location	Procedure	Not Fully Mission Capable If:
		Item To Check/ Service		
4	Before	ROOF	a. Inspect roof armor panels for damage or loose or missing mounting hardware. b. Inspect roof armor panels for areas of rust or corrosion. c. Inspect roof armor panels for cracks near or elongation of bolt holes. d. Inspect roof armor panels for any holes or gouges.	Any panel or armor plate is damaged, bent out of shape, misaligned, loose or missing, or mounting bolts are loose or missing. Any corrosion where area is unsound and small pin holes are present, or a rusted through condition is present. Any cracks that are longer than 1" or two consecutive bolt holes that are elongated. Any complete penetration of the armor (hole in the armor) or multiple gouges 1/4" or deeper within 3" of each other.
		Roof Armor		

ROOF ARMOR




417-269

Item No.	Interval	Location	Procedure	Not Fully Mission Capable If:
		Item To Check/Service		
5	Before	<b>REAR AND RIGHT SIDE</b>	<p>a. Inspect rear cab armor panels for damage or loose or missing mounting hardware.</p> <p>b. Inspect rear cab armor panels for areas of rust or corrosion.</p> <p>c. Inspect rear cab armor panels for cracks near or elongation of bolt holes.</p> <p>d. Inspect rear cab armor panels for any holes or gouges.</p> <p>e. Inspect escape hatch ballistic glass mounting hardware for damage, loose, or missing mounting hardware.</p> <p>f. Inspect interior surface of escape hatch ballistic glass for rock chips, cracks, scratches, pitting, any hits that expose glass below the first layer, cloudiness, or any stickers that impair vision.</p> <p>g. Exit vehicle and inspect exterior surface of escape hatch ballistic glass for rock chips, cracks, scratches, pitting, any hits that expose glass below the first layer, cloudiness, or any stickers that impair vision.</p>	<p>Any panel or armor plate is damaged, bent out of shape, misaligned, loose or missing, or mounting bolts are loose or missing.</p> <p>Any corrosion where area is unsound and small pin holes are present, or a rusted through condition is present.</p> <p>Any cracks that are longer than 1" or two consecutive bolt holes that are elongated.</p> <p>Any complete penetration of the armor (hole in the armor) or multiple gouges 1/4" or deeper within 3" of each other.</p> <p>Any ballistic glass mounting hardware is damaged, loose, or missing, or mounting bolts are loose or missing.</p> <p>Rock chips, cracks with spider webbing, scratches, pitting, or hits in the exterior layer of ballistic glass that expose glass below the first layer, cloudiness that impairs vision.</p> <p>Rock chips, cracks with spider webbing, scratches, pitting, or hits in the exterior layer of ballistic glass that expose glass below the first layer, cloudiness that impairs vision.</p>
		<b>Rear Cab Armor</b>		

OPERATOR PREVENTIVE MAINTENANCE CHECKS AND SERVICES (PMCS) - CONTINUED

0009 00

Item No.	Interval	Location	Procedure	Not Fully Mission Capable If:
		Item To Check/Service		
5 (Con't)	Before	Rear Cab Armor		
 <p>417-298</p>				

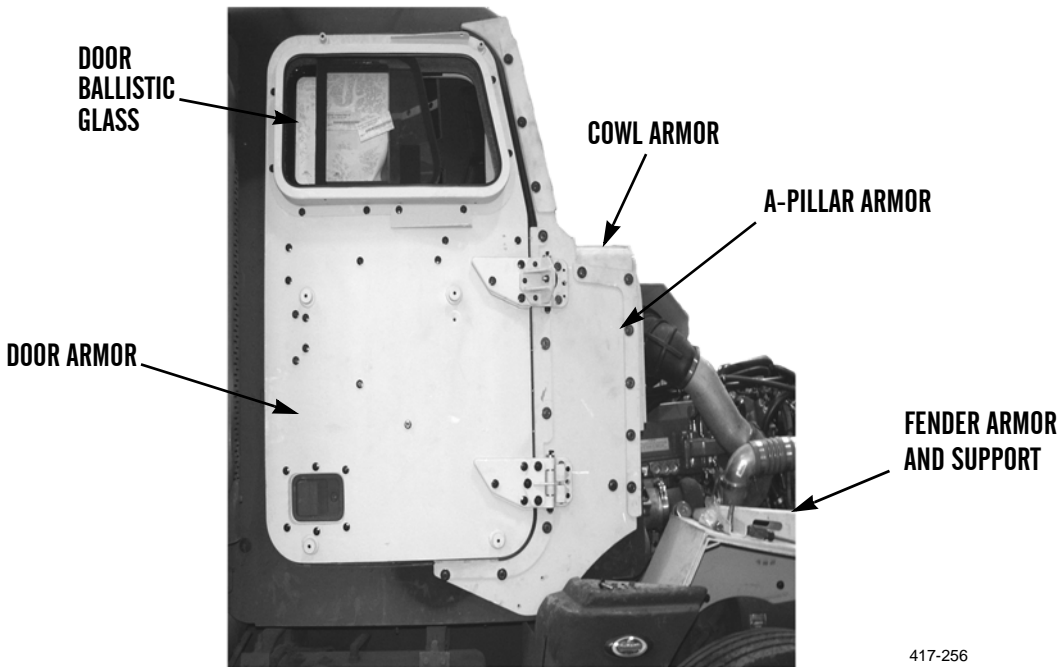
OPERATOR PREVENTIVE MAINTENANCE CHECKS AND SERVICES (PMCS) - CONTINUED

0009 00

Item No.	Interval	Location	Procedure	Not Fully Mission Capable If:
		Item To Check/ Service		
6	Before	Side Armor (Right Side)	<p>a. Inspect A-pillar armor panels for damage or loose or missing mounting hardware.</p> <p>b. Inspect A-pillar armor panels for areas of rust or corrosion.</p> <p>c. Inspect A-pillar armor panels for cracks near or elongation of bolt holes.</p> <p>d. Inspect A-pillar armor panels for any holes or gouges.</p> <p>e. Inspect door ballistic glass mounting hardware for damage, loose, or missing mounting hardware.</p> <p>f. Inspect exterior surface of door ballistic glass for rock chips, cracks, scratches, pitting, any hits that expose glass below the first layer, cloudiness, or any stickers that impair vision.</p> <p>g. Inspect fender armor and support for damage or loose or missing mounting hardware.</p> <p>h. Inspect fender armor and support for areas of rust or corrosion.</p> <p>i. Inspect fender armor and support for cracks near or elongation of bolt holes.</p> <p>j. Inspect fender armor and support for any holes or gouges.</p> <p>k. Open door and enter cab. Close door using grab handle. Make sure door closes without binding and locks correctly (WP 0004 00).</p> <p>l. Make sure door ballistic glass can open, close, and securely lock.</p>	<p>Any panel or armor plate is damaged, bent out of shape, misaligned, loose or missing, or mounting bolts are loose or missing.</p> <p>Any corrosion where area is unsound and small pin holes are present, or a rusted through condition is present.</p> <p>Any cracks that are longer than 1" or two consecutive bolt holes that are elongated.</p> <p>Any complete penetration of the armor (hole in the armor) or multiple gouges 1/4" or deeper within 3" of each other.</p> <p>Any ballistic glass mounting hardware is damaged, loose, or missing, or mounting bolts are loose or missing.</p> <p>Rock chips, cracks with spider webbing, scratches, pitting, or hits in the exterior layer of ballistic glass that expose glass below the first layer, cloudiness that impairs vision.</p> <p>Any panel or armor plate is damaged, bent out of shape, misaligned, loose or missing, or mounting bolts are loose or missing.</p> <p>Any corrosion where area is unsound and small pin holes are present, or a rusted through condition is present.</p> <p>Any cracks that are longer than 1" or two consecutive bolt holes that are elongated.</p> <p>Any complete penetration of the armor (hole in the armor) or multiple gouges 1/4" or deeper within 3" of each other.</p> <p>Door binds or does not lock.</p> <p>Door ballistic glass will not close or lock.</p>

OPERATOR PREVENTIVE MAINTENANCE CHECKS AND SERVICES (PMCS) - CONTINUED

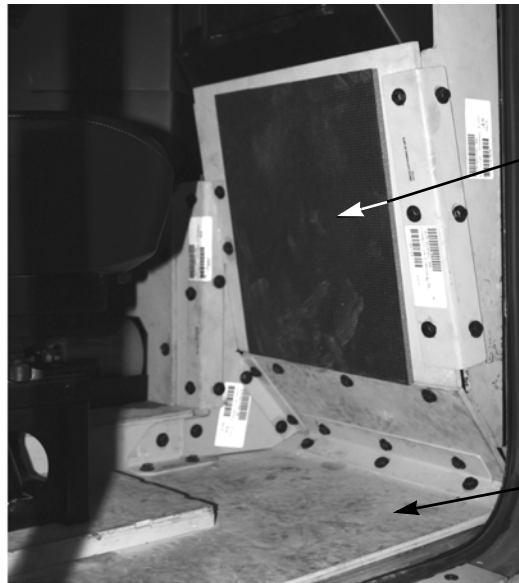
0009 00

Item No.	Interval	Location	Procedure	Not Fully Mission Capable If:
		Item To Check/Service		
6 (Con't)	Before	Side Armor (Right Side)	<p>m. Inspect interior surface of door ballistic glass and windshield ballistic glass for rock chips, cracks, scratches, pitting, any hits that expose glass below the first layer, cloudiness, or any stickers that impair vision.</p> <p>n. If dirty, clean ballistic glass (WP 0010 00).</p>	Rock chips, cracks with spider webbing, scratches, pitting, or hits in the exterior layer of ballistic glass that expose glass below the first layer, cloudiness that impairs vision.
				
				417-256

OPERATOR PREVENTIVE MAINTENANCE CHECKS AND SERVICES (PMCS) - CONTINUED

0009 00

Item No.	Interval	Location	Procedure	Not Fully Mission Capable If:
		Item To Check/ Service		
7	Before	Floor /Fire-wall Armor (Right Side)	<p>a. Inspect right side floor and firewall armor panels for damage or loose or missing mounting hardware.</p> <p>b. Inspect right side floor and firewall armor panels for areas of rust or corrosion.</p> <p>c. Inspect right side floor and firewall armor panels for cracks near or elongation of bolt holes.</p> <p>d. Inspect right side floor and firewall armor panels for any holes or gouges.</p>	<p>Any panel or armor plate is damaged, bent out of shape, misaligned, loose or missing, or mounting bolts are loose or missing.</p> <p>Any corrosion where area is unsound and small pin holes are present, or a rusted through condition is present.</p> <p>Any cracks that are longer than 1" or two consecutive bolt holes that are elongated.</p> <p>Any complete penetration of the armor (hole in the armor) or multiple gouges 1/4" or deeper within 3" of each other.</p>



FIREWALL ARMOR

FLOOR ARMOR

417-257

8	Weekly	Front Suspension	Inspect front suspension springs and mounting hardware for cracks, breaks, or loose or missing hardware and/or shackles. Notify your supervisor of any damage found.	Any cracks, breaks, or loose hardware or damage to suspension springs is noted.
9	Weekly	Cab Mounts	Inspect cab mounts for evidence of deterioration, over compression or loose mounting hardware. Notify your supervisor of any damage or looseness found.	Deterioration, over compression, or loose mounting hardware is noted.

OPERATOR PREVENTIVE MAINTENANCE CHECKS AND SERVICES (PMCS) - CONTINUED

0009 00

Item No.	Interval	Location	Procedure	Not Fully Mission Capable If:
		Item To Check/Service		
10	Weekly	Wheels and Wheel Rims	Inspect wheel lug nuts and wheel rim bolts/nuts for looseness (e.g., polished surface, rust, or minor cracks around bolt and wheel mating surfaces). Notify your supervisor of any looseness found.	Two or more studs or nuts are missing from the same wheel.
11	Weekly	Crew Protection Kit Mounting Hardware	Check all armor kit mounting hardware for loose or missing hardware. Notify your supervisor of any loose or missing mounting hardware found.	Loose or missing mounting hardware is noted.
12	Weekly	Escape Hatch	a. From inside the cab, check that escape hatch door will open and then securely latch closed. Ensure there is no damage to pins and mounting hardware.  b. Inspect for damage to escape hatch seal. Notify your supervisor of any damage found.	Escape hatch door will not open or latch closed securely.
13	Weekly	Door Assemblies	Check both door assembly seals, hardware and door stops for damaged or loose components. Notify your supervisor of any damage found.	Door assembly is damaged, loose or missing or mounting bolts are loose or missing.

END OF WORK PACKAGE





---

**CLEANING BALLISTIC GLASS**

**0010 00**

---

**THIS WORK PACKAGE COVERS**

Cleaning

---

**INITIAL SETUP**

**Maintenance Level**

Operator

**Materials/Parts**

Detergent (Item 4, WP 0034 00)

Rag, Wiping (Item 6, WP 0034 00)

**Equipment Conditions**

**(M915A3P1, M916A3P1, and M917A2P1)**

Vehicle parked on level ground (TM 9-2320-302-10)

Parking/Emergency Brake applied (TM 9-2320-302-10)

Engine off (TM 9-2320-302-10)

Battery Disconnect Switch in OFF position (TM 9-2320-302-10)

**Equipment Conditions - Continued**

**(M915A4P1)**

Vehicle parked on level ground (TM 9-2320-303-10)

Parking/Emergency Brake applied (TM 9-2320-303-10)

Engine off (TM 9-2320-303-10)

Battery Disconnect Switch in OFF position (TM 9-2320-303-10)

**(M915A2P1, M916A1P1, M916A2P1, and M917A1P1)**

Vehicle parked on level ground (TM 9-2320-363-10)

Parking/Emergency Brake applied (TM 9-2320-363-10)

Engine off (TM 9-2320-363-10)

If equipped, Battery Disconnect Switch in OFF position (TM 9-2320-363-10), otherwise disconnect battery cables (TM 9-2320-363-20-2)

---

**CLEANING**

**CAUTION**

- Remove rings or other hard objects from hands before cleaning ballistic glass. DO NOT use hard, dirty, or gritty cloths on ballistic glass. DO NOT apply water or detergent unless ballistic glass is cool and is protected from heating effects of sunlight. Failure to follow these instructions will damage ballistic glass.
- Do not use bug spray or other aerosol sprays on or near ballistic glass. Failure to follow these instructions will damage ballistic glass.

**NOTE**

Follow this procedure to clean inner plastic laminate surfaces of ballistic glass. Clean outside surfaces of ballistic glass as you would clean plain glass as directed by manufacturer.

1. Add detergent to 1 gal. (3.8 L) of water as directed by manufacturer.
2. Saturate a soft, clean cloth with cleaning solution and lightly rub plastic surfaces.
3. Flush off cleaning solution with water and dry with a soft, clean cloth.

**END OF WORK PACKAGE**



**CHAPTER 4**  
**UNIT MAINTENANCE INSTRUCTIONS**



---

**GENERAL MAINTENANCE INSTRUCTIONS**

**0011 00**

---

**THIS WORK PACKAGE COVERS**

Scope	Standard Tool Requirements
Work Safety	Use of Thread Adhesive
General Information	Use of Sealant
Cleaning Instructions	Applying Torque
Inspection Instructions	Tagging Instructions
Painting Instructions	

---

**INITIAL SETUP**

**Maintenance Level**

Unit

**Tools and Special Tools**

Tool Kit, General Mechanic's (Item 8, WP 0033 00)  
 Shop Equipment, Common No. 1 (Item 6, WP 0033 00)

**Materials/Parts**

Adhesive, Thread (Item 1, WP 0034 00)  
 Cleaning Compound, Solvent (Item 2, WP 0034 00)  
 Cloth, Abrasive (Item 3, WP 0034 00)  
 Detergent (Item 4, WP 0034 00)

**Materials/Parts - Continued**

Oil, Lubricating (Item 5, WP 0034 00)  
 Rag, Wiping (Item 6, WP 0034 00)  
 Tag, Marker (Item 10, WP 0034 00)

**References**

WP 0031 00  
 WP 0035 00  
 TB 43-0209  
 TB 43-0242  
 TM 9-247

---

**SCOPE**

1. These general maintenance instructions contain general shop practices and specific methods you must be familiar with to properly install and maintain the Crew Protection Kit.
2. Read and understand these practices and methods before starting maintenance tasks on the Crew Protection Kit.

**WORK SAFETY**



**WARNING**

- Use caution when handling window glass. Glass can break unexpectedly during removal/installation procedure. Wear face shield, apron, and gloves. Failure to follow this warning may cause injury to personnel.
  - Edges of metal armor panels may be sharp. Wear protective gloves when handling armor panels. Failure to follow this warning may cause injury to personnel.
1. Before starting a task, think about the risks and hazards to your safety as well as others. Wear protective gear such as safety goggles or lenses, face shield, safety shoes, and gloves. Protect yourself against injury.
  2. Observe all WARNINGS and CAUTIONS.

---

**GENERAL MAINTENANCE INSTRUCTIONS - CONTINUED**

---

0011 00

**WORK SAFETY - CONTINUED**

3. When lifting heavy parts, have someone help you. Make sure that lifting equipment is working properly, that it is suitable for the task assigned, of sufficient load capacity and is secured against slipping.
4. Always use power tools carefully.
5. Before beginning a procedure, ensure that the following conditions have been observed, unless otherwise specified:
  - a. Vehicle must be parked on level ground with parking/emergency brake applied.
  - b. Transmission must be in N (Neutral).
  - c. Engine must be off.
  - d. Battery disconnect switch must be in OFF position.

These procedures are located in Operator Technical Manual for specific vehicle. Refer to *References* (WP 0031 00).

**GENERAL INFORMATION**

1. Before beginning a task, find out how much teardown is needed to fix the equipment as described in this manual. Sometimes complete teardown is not necessary. Remove components only as far as necessary to replace damaged or broken parts.
2. All tags and forms attached to the equipment must be checked to learn the reason for removal from service. Check all Modification Work Orders (MWOs) and Technical Bulletins (TBs) for equipment changes and updates.
3. Replace all locknuts and lockwashers if removed during procedure.
4. Inspect seals for damage. Replace seals if damaged.

**CLEANING INSTRUCTIONS**

1. **General.**
  - a. The importance of cleaning must be thoroughly understood by maintenance personnel. Great care and effort are required in cleaning. Dirt and foreign material are a constant threat to satisfactory maintenance.
  - b. The following should apply to all cleaning operations:
    - (1) Keep all related parts and components together. DO NOT mix parts.
    - (2) Clean all parts before inspection and before installation.
    - (3) To prevent contamination, hands should be kept free of accumulation of grease, which can collect dust, dirt, or grit.

**CLEANING INSTRUCTIONS - CONTINUED**2. **Cleaning Instructions.****WARNING**

- Solvent cleaning compound MIL-PRF-680 Type III is an environmentally compliant and low toxic material. However, it may be irritating to the eyes and skin. Use protective gloves and goggles. Use in well-ventilated areas. Keep away from open flames and other sources of ignition. Failure to follow this warning may result in injury to personnel.
  - Improper cleaning methods and use of unauthorized cleaning solvents may injure personnel and damage equipment. Refer to TM 9-247, *Materials Used for Cleaning, Preserving, Abrading, and Cementing Ordnance Materiels and Related Materiels Including Chemicals*, for correct information.
  - Fire extinguishers should be placed nearby when using solvent cleaning compound.
  - Cloths or rags saturated with solvent cleaning compound must be disposed of IAW authorized facilities' procedures.
  - Eye shields must be worn when cleaning with a wire brush. Flying rust and metal particles may cause injury.
  - Particles blown by compressed air are hazardous. DO NOT exceed 15 psi (103 kPa) nozzle pressure when drying parts with compressed air. Use a maximum of 30 psi (207 kPa) when cleaning components. DO NOT direct compressed air against human skin. Failure to follow this warning may result in injury or death. Make sure air stream is directed away from user and other personnel in the area. To prevent injury, user must wear protective goggles or face shield.
- a. Use solvent cleaning compound to clean any surface coated with grease or oil.
  - b. Clear out all drilled or tapped (threaded) holes with compressed air to remove dirt and solvent cleaning compound.
  - c. Wash externally exposed parts, not subject to grease and oil, with detergent and water. Rinse thoroughly and air dry.
  - d. Remove old sealing compound using a wire brush and solvent cleaning compound.
  - e. Clean all rusted surfaces using a wire brush and abrasive cloth.
  - f. After cleaning, cover or wrap all parts to protect them from dust and dirt. Any part that is subject to rust should be lightly coated with lubricating oil.

**INSPECTION INSTRUCTIONS**

1. **General.** All components and parts must be carefully inspected to determine if they are serviceable for reuse or if they must be replaced.
2. **Drilled and Tapped (Threaded) Holes.**
  - a. Inspect for wear, distortion (stretching), cracks, or any other damage in or around holes.
  - b. Inspect threaded areas for wear, distortion, or evidence of cross-threading.
  - c. If damage is noted, entire part should be replaced.
3. **Armor Plates.**
  - a. Inspect for breaks, cracks, dents, and rust damage.
  - b. Particularly check areas around studs, screw openings, and sharp corners.

**INSPECTION INSTRUCTIONS - CONTINUED****WARNING**

To ensure survivability of personnel, welding repairs on Crew Protection Kit are NOT authorized. If armor plates are damaged, they must be replaced. Failure to follow this warning may cause failure of armor, resulting in injury or death to personnel.

- c. Replace any damaged armor plate. DO NOT repair by welding.
4. **Bolts and Screws.** Replace if threads are damaged, bent, loose, or stretched.
5. **Studs.** If studs are damaged, repair or replace as necessary.
6. **Rubber Seals.** Replace seal if damaged, cracked, or shows signs of excessive wear.

**PAINTING INSTRUCTIONS****CAUTION**

Whenever paint is applied, care must be taken to prevent covering up installation aid markings (**THIS SIDE UP**, up arrows ↑↑, etc.). These installation aid markings must be protected during paint application by using masking tape, paper, etc.

Parts must be painted in accordance with TB 43-0209, *Color, Marking, and Camouflage Painting of Military Vehicles, Construction Equipment, and Materials Handling Equipment*, and TB 43-0242, *CARC Spot Painting*.

**STANDARD TOOL REQUIREMENTS**

1. The following are general practices regarding the use of tools:
  - a. Always use the proper tool kit and tools for the procedure being performed.
  - b. Ensure that tools are clean and lubricated to reduce wear and to prevent rust.
  - c. Keep track of tools. DO NOT be careless with them.
  - d. Return tools to toolbox when finished with repair or maintenance.
  - e. Return toolboxes and tools to tool storage when not in use.
  - f. Inventory tools before and after each use.
2. Some maintenance tasks may require special or fabricated tools. The "Initial Setup" of the procedure will specify any special or fabricated tools needed to perform that procedure. Use these special tools only for the maintenance procedures for which they are designed or called out. If you are unfamiliar with a required tool, see your supervisor.

**USE OF THREAD ADHESIVE****WARNING**

Use caution when using adhesives and sealants. Prolonged inhalation of vapors can cause lung irritation. Contact with skin can cause dermatitis. Wear gloves and safety goggles and use product in a well-ventilated area away from open flame. If ingested, keep individual calm and seek medical attention. DO NOT induce vomiting. If contact with skin or eyes is made, flush thoroughly with water. Dispose of cleanup rags IAW local policy and ordinances. Failure to follow this warning may cause injury to personnel.

Selected bolts and screws require use of adhesive during installation of the armor kit, or when replacing armor kit components. Generally, if no locking fastener (i.e., locknut or lockwasher) is used, thread adhesive is required.



---

**GENERAL MAINTENANCE INSTRUCTIONS - CONTINUED**

---

0011 00

**USE OF SEALANT**

1. When applying sealant, follow manufacturers instructions on label of container.
2. Sealant should be applied with an even and continuous 1/4 inch bead along mating surfaces.

**APPLYING TORQUE**

1. When tightening fasteners, use torque value as specified in *Torque Limits* (WP 0035 00).
2. If a unique torque value is required, it will be provided in the procedural step of the task.

**TAGGING INSTRUCTIONS**

1. Use marker tags to identify all electrical wires and any other parts which may be hard to identify or replace later. Fasten tags to parts during removal by wrapping wire fasteners around or through parts and twisting ends together. Position tags to be out of the way during cleaning, inspection, and repair. Mark tags with a pencil, pen, or marker.
2. Whenever possible, identify electrical wires with the number of the terminal or wire to which it connects. If no markings can be found, tag both wires or wire and terminal, and use the same identifying mark for both. If you cannot tag a wire because it must fit through a small hole or you cannot reach it, write down the description of the wire and the point to which it connects or draw a simple diagram on paper. Be sure to write down enough information so you will be able to properly connect the wires during assembly. If you need to identify a loose wire, look for identifying number near end of the wire, stamped on a permanent metal tag. Compare the number to wire numbers on the appropriate electrical schematic.
3. Identify and tag other parts as required by name and installed location.

**END OF WORK PACKAGE**



---

**DOOR ASSEMBLY REPLACEMENT**

**0012 00**

---

**THIS WORK PACKAGE COVERS**

Removal, Cleaning and Inspection, Installation

---

**INITIAL SETUP**

**Maintenance Level**

Unit

**Tools and Special Tools**

Tool Kit, General Mechanic's (Item 8, WP 0033 00)

Shop Equipment, Common No. 1 (Item 6, WP 0033 00)

Sling, Nylon (Item 7, WP 0033 00)

Link, Lifting (Item 5, WP 0033 00)

Device, Lifting (500-lb capacity)

**Materials/Parts**

Rag, Wiping (Item 6, WP 0034 00)

**References**

WP 0011 00

WP 0016 00

**Personnel Required**

Two

**Equipment Conditions**

**(M915A3P1, M916A3P1, and M917A2P1)**

Vehicle parked on level ground (TM 9-2320-302-10)

Parking/Emergency Brake applied (TM 9-2320-302-10)

Engine off (TM 9-2320-302-10)

Battery Disconnect Switch in OFF position (TM 9-2320-302-10)

**Equipment Conditions - Continued**

**(M915A3P1, M916A3P1, and M917A2P1) - Continued**

Outside Door Mirror removed (TM 9-2320-302-20-2)

**(M915A4P1)**

Vehicle parked on level ground (TM 9-2320-303-10)

Parking/Emergency Brake applied (TM 9-2320-303-10)

Engine off (TM 9-2320-303-10)

Battery Disconnect Switch in OFF position (TM 9-2320-303-10)

Outside Door Mirror removed (TM 9-2320-303-24-1)

**(M915A2P1, M916A1P1, M916A2P1, and M917A1P1)**

Vehicle parked on level ground (TM 9-2320-363-10)

Parking/Emergency Brake applied (TM 9-2320-363-10)

Engine off (TM 9-2320-363-10)

If equipped, Battery Disconnect Switch in OFF position (TM 9-2320-363-10), otherwise, disconnect battery cables (TM 9-2320-363-20-2)

Outside Door Mirror removed (TM 9-2320-363-20-2)

---

**NOTE**

The following procedure is for right door assembly. Use same procedure for left door assembly.

**DOOR ASSEMBLY REPLACEMENT - CONTINUED**

0012 00

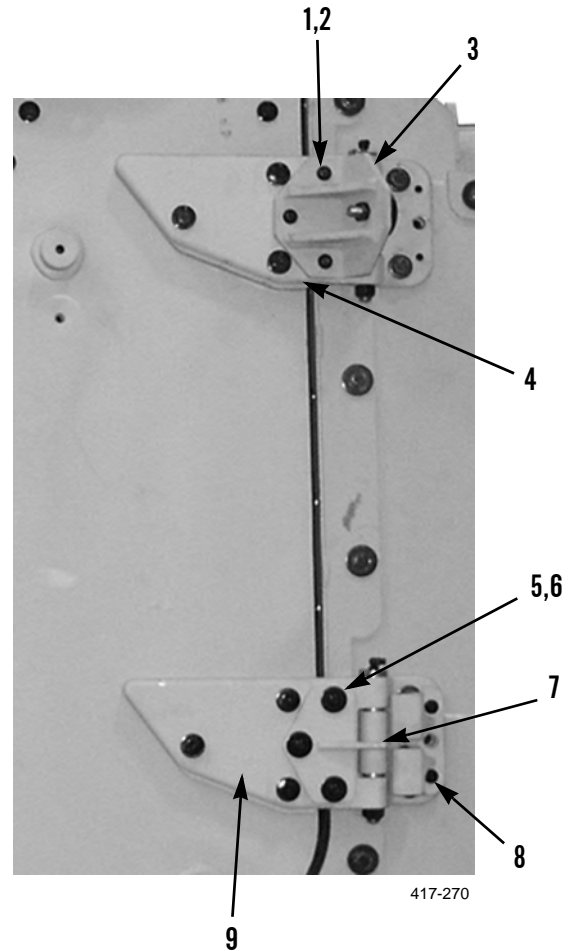
**REMOVAL**

1. Remove three bolts (1), washers (2), and upper hinge door bumper (3) from upper hinge assembly (4).

**NOTE**

Note location of bolts when removed as one bolt is longer.

2. Remove four bolts (5), washers (6), two bolts (8), and lower hinge door detent (7) from lower hinge assembly (9).

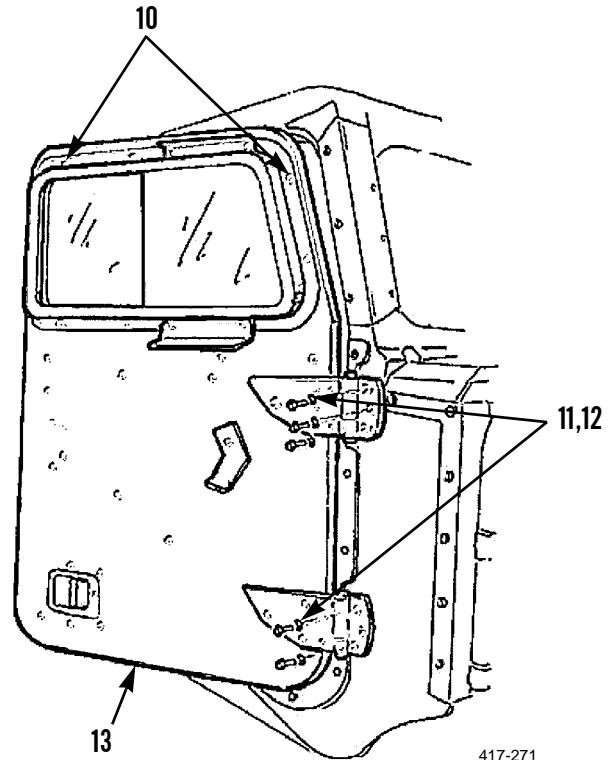
**WARNING**

Use extreme caution when handling heavy parts. Provide adequate support and use assistance during procedure. Ensure that any lifting device used is in good condition and of suitable load capacity. Keep clear of heavy parts supported only by lifting device. Failure to follow this warning may cause injury or death to personnel.

**REMOVAL - CONTINUED****NOTE**

Door assembly weighs 330 lb (150 kg).

3. Install two lifting links on two weld bosses (10).
4. Attach lifting device to two lifting links on door assembly (13).
5. Using lifting device, hold door suspended and remove five bolts (11), washers (12), and door assembly (13) from vehicle.
6. Remove lifting device from door assembly (13).
7. Remove two lifting links from two weld bosses (10).

**CLEANING AND INSPECTION**

Clean and inspect all parts IAW *General Maintenance Instructions* (WP 0011 00).

**INSTALLATION****WARNING**

Use extreme caution when handling heavy parts. Provide adequate support and use assistance during procedure. Ensure that any lifting device used is in good condition and of suitable load capacity. Keep clear of heavy parts supported only by lifting device. Failure to follow this warning may cause injury or death to personnel.

**NOTE**

Door assembly weighs 330 lb (150 kg).

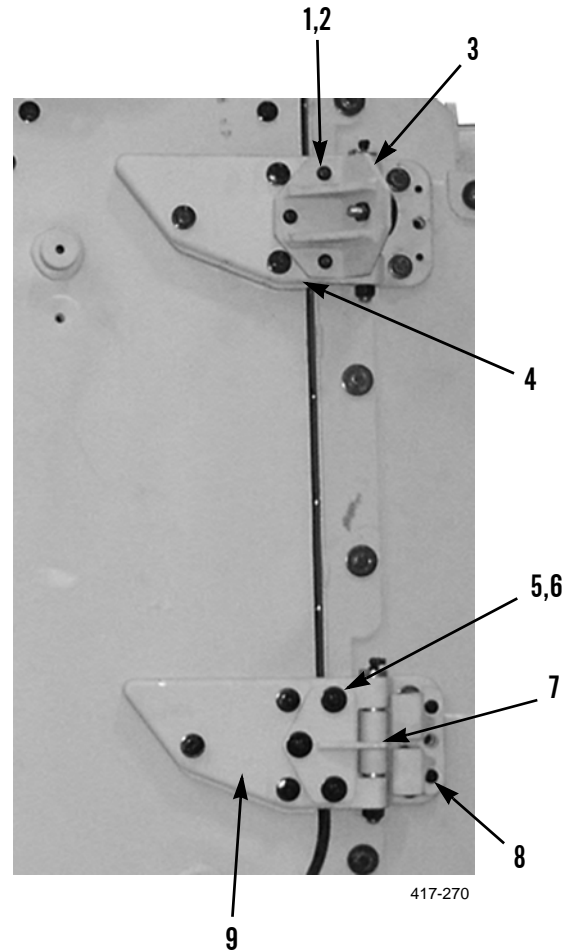
1. Attach two lifting links to two weld bosses (10).
2. Attach lifting device to door assembly (13).
3. Using lifting device, align holes in door assembly (13) with holes on side of cab and install five washers (12), bolts (11), and door assembly (13) to vehicle.
4. Check alignment between door assembly (13) and cab opening. Adjust door assembly as necessary until alignment is correct.
5. Remove two lifting links from two weld bosses (10).

**DOOR ASSEMBLY REPLACEMENT - CONTINUED**

0012 00

**INSTALLATION - CONTINUED**

6. Install lower hinge (9), door detent (7) to lower hinge assembly with four washers (6), bolts (5) and two bolts (8).
7. Install upper hinge (4), door bumper (3) to upper hinge assembly with three washers (2) and bolts (1).
8. Verify correct operation of door assembly.



9. Check alignment of latch (WP 0016 00).
10. If removed, install outside mirror on door assembly. For the M915A3P1, M916A3P1, and M917A2P1, refer to TM 9-2320-302-20-2 series. For the M915A4P1, refer to TM 9-2320-303-24-1. For the M915A2P1, M916A1P1, M916A2P1, and M917A1P1, refer to TM 9-2320-363-20-2.

**END OF WORK PACKAGE**

---

**DOOR HANDLE REPLACEMENT**

**0013 00**

---

**THIS WORK PACKAGE COVERS**

Removal, Cleaning and Inspection, Installation

---

**INITIAL SETUP**

**Maintenance Level**

Unit

**Tools and Special Tools**

Tool Kit, General Mechanic's (Item 8, WP 0033 00)

**Materials/Parts**

Rag, Wiping (Item 6, WP 0034 00)

**References**

WP 0011 00

WP 0016 00

**Equipment Conditions**

**(M915A3P1, M916A3P1, and M917A2P1)**

Vehicle parked on level ground (TM 9-2320-302-10)

Parking/Emergency Brake applied (TM 9-2320-302-10)

Engine off (TM 9-2320-302-10)

Battery Disconnect Switch in OFF position (TM 9-2320-302-10)

**Equipment Conditions - Continued**

**(M915A4P1)**

Vehicle parked on level ground (TM 9-2320-303-10)

Parking/Emergency Brake applied (TM 9-2320-303-10)

Engine off (TM 9-2320-303-10)

Battery Disconnect Switch in OFF position (TM 9-2320-303-10)

**(M915A2P1, M916A1P1, M916A2P1, and M917A1P1)**

Vehicle parked on level ground (TM 9-2320-363-10)

Parking/Emergency Brake applied (TM 9-2320-363-10)

Engine off (TM 9-2320-363-10)

If equipped, Battery Disconnect Switch in OFF position (TM 9-2320-363-10), otherwise, disconnect battery cables (TM 9-2320-363-20-2)

---

**NOTE**

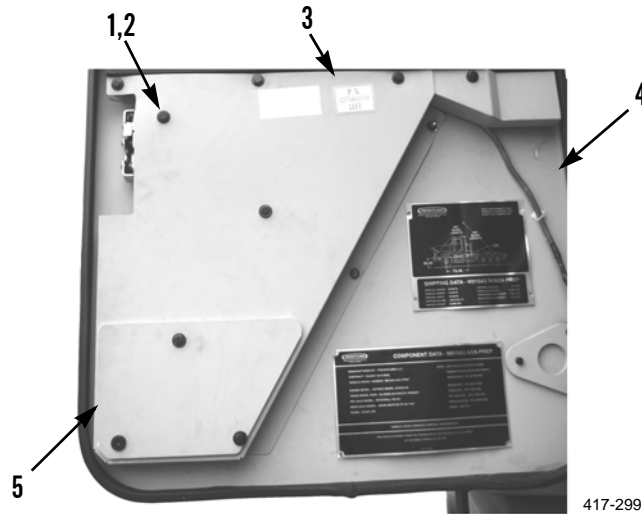
The following procedure is for left door handles. Use same procedure for right door handles.

## DOOR HANDLE REPLACEMENT - CONTINUED

0013 00

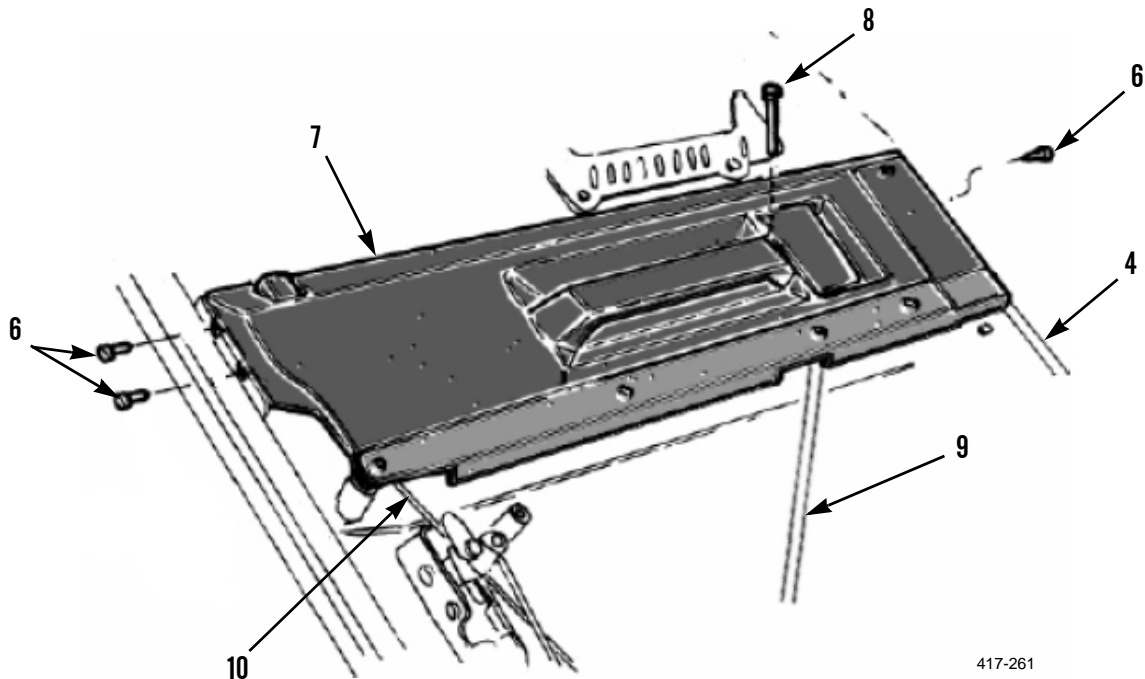
**REMOVAL**

1. Remove eight screws (2), washers (1), lower panel (5), and door panel (3) from door assembly (4).



417-299

2. Remove three screws (6), screw (8), and interior handle assembly (7) from door assembly (4).
3. Disconnect lock rod (10) and interior handle rod (9) from interior handle assembly (7).



417-261

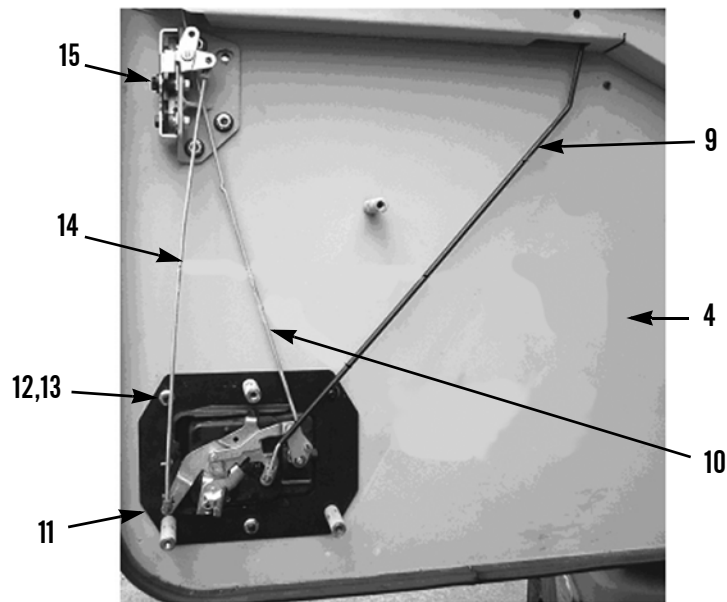


**DOOR HANDLE REPLACEMENT - CONTINUED**

0013 00

**REMOVAL - CONTINUED**

4. Disconnect interior handle rod (9) from exterior handle assembly (11).
5. Disconnect exterior handle rod (14) from exterior handle assembly (11) and from door latch (15).
6. Disconnect lock rod (10) from exterior handle assembly (11).
7. Remove three nuts (12), bolts (13), and exterior handle assembly (11) from door (4).



417-262

**CLEANING AND INSPECTION**

Clean and inspect all parts IAW *General Maintenance Instructions* (WP 0011 00).

**INSTALLATION**

1. Install exterior handle assembly (11), three bolts (13), and nuts (12) on door assembly (4).
2. Connect lock rod (10) on exterior handle assembly (11).
3. Connect exterior handle rod (14) to exterior handle assembly (11) and to door latch (15).
4. Connect interior handle rod (9) to exterior handle assembly (11).
5. Connect lock rod (10) and interior handle rod (9) on interior handle assembly (7).
6. Install interior handle assembly (7), three screws (6), and screw (8) on door assembly (4).
7. Install door panel (3), lower panel (5), eight washers (1), and screws (2) on door assembly (4).
8. Check alignment of door latch (WP 0016 00).

**END OF WORK PACKAGE**



---

**DOOR LATCH REPLACEMENT**

**0014 00**

---

**THIS WORK PACKAGE COVERS**

Removal, Cleaning and Inspection, Installation

---

**INITIAL SETUP**

**Maintenance Level**

Unit

**Tools and Special Tools**

Tool Kit, General Mechanic's (Item 8, WP 0033 00)

**Materials/Parts**

Rag, Wiping (Item 6, WP 0034 00)

Locknut (6)

**References**

WP 0004 00

WP 0011 00

**Equipment Conditions**

**(M915A3P1, M916A3P1, and M917A2P1)**

Vehicle parked on level ground (TM 9-2320-302-10)

Parking/Emergency Brake applied (TM 9-2320-302-10)

Engine off (TM 9-2320-302-10)

Battery Disconnect Switch in OFF position (TM 9-2320-302-10)

**Equipment Conditions - Continued**

**(M915A4P1)**

Vehicle parked on level ground (TM 9-2320-303-10)

Parking/Emergency Brake applied (TM 9-2320-303-10)

Engine off (TM 9-2320-303-10)

Battery Disconnect Switch in OFF position (TM 9-2320-303-10)

**(M915A2P1, M916A1P1, M916A2P1, and M917A1P1)**

Vehicle parked on level ground (TM 9-2320-363-10)

Parking/Emergency Brake applied (TM 9-2320-363-10)

Engine off (TM 9-2320-363-10)

If equipped, Battery Disconnect Switch in OFF position (TM 9-2320-363-10), otherwise, disconnect battery cables (TM 9-2320-363-20-2)

---

**NOTE**

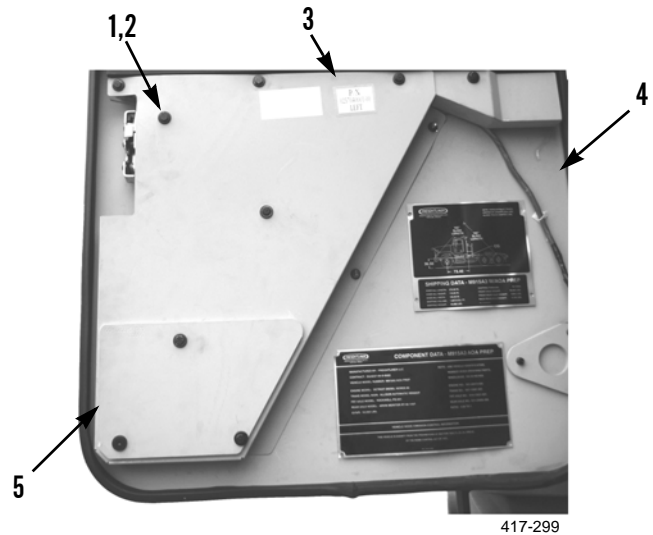
The following procedure is for left side latch. Use same procedure for right side latch.

**DOOR LATCH REPLACEMENT - CONTINUED**

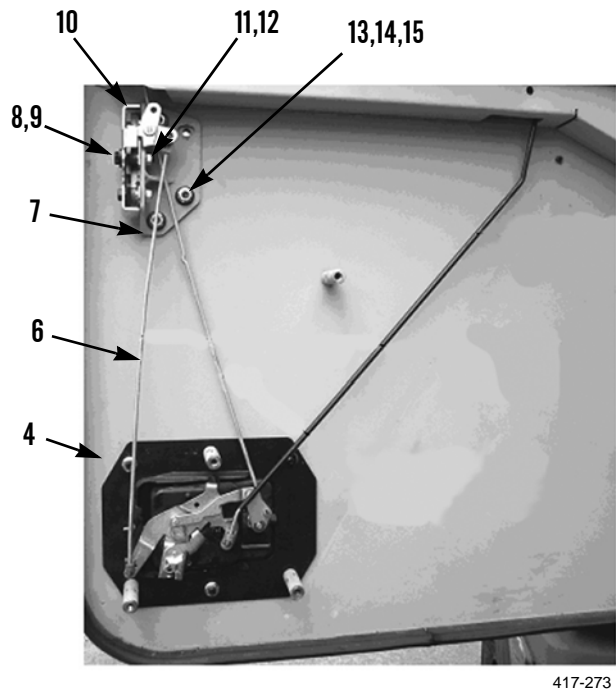
0014 00

**REMOVAL**

1. Remove eight screws (2), washers (1), lower panel (5), and door panel (3) from door assembly (4).



2. Disconnect outside door handle linkage (6) from door latch (10).
3. Remove three locknuts (11), washers (12), bolts (8), washers (9), and door latch (10) from latch bracket (7). Discard locknuts.
4. Remove three locknuts (13), washers (14), bolts (15), and door latch bracket (7) from door assembly (4). Discard locknuts.

**CLEANING AND INSPECTION**

Clean and inspect all parts IAW *General Maintenance Instructions* (WP 0011 00).

---

**DOOR LATCH REPLACEMENT - CONTINUED**

---

**0014 00**

***INSTALLATION***

1. Install door latch bracket (7), three bolts (15), washers (14), and new locknuts (13) on door assembly (4).
2. Install door latch (10), three washers (9), bolts (8), washers (12), and new locknuts (11) on latch bracket (7).
3. Connect outside door handle linkage (6) to door latch (10).
4. Install door panel (3), lower panel (5), eight washers (1), and screws (2) on door assembly (4).
5. Verify correct operation of door assembly (WP 0004 00).

**END OF WORK PACKAGE**



---

**DOOR BALLISTIC GLASS AND FRAME ASSEMBLY REPLACEMENT**

---

**0015 00**

**THIS WORK PACKAGE COVERS**

Removal, Cleaning and Inspection, Installation

---

**INITIAL SETUP**

**Maintenance Level**

Unit

**Tools and Special Tools**

Tool Kit, General Mechanic's (Item 8, WP 0033 00)

**Materials/Parts**

Rag, Wiping (Item 6, WP 0034 00)

**References**

WP 0011 00

**Personnel Required**

Two

**Equipment Conditions**

**(M915A3P1, M916A3P1, and M917A2P1)**

Vehicle parked on level ground (TM 9-2320-302-10)

Parking/Emergency Brake applied (TM 9-2320-302-10)

Engine off (TM 9-2320-302-10)

Battery Disconnect Switch in OFF position (TM 9-2320-302-10)

Outside Door Mirror removed (TM 9-2320-302-20)

**Equipment Conditions - Continued**

**(M915A4P1)**

Vehicle parked on level ground (TM 9-2320-303-10)

Parking/Emergency Brake applied (TM 9-2320-303-10)

Engine off (TM 9-2320-303-10)

Battery Disconnect Switch in OFF position (TM 9-2320-303-10)

Outside Door Mirror removed (TM 9-2320-303-24-1)

**(M915A2P1, M916A1P1, M916A2P1, and M917A1P1)**

Vehicle parked on level ground (TM 9-2320-363-10)

Parking/Emergency Brake applied (TM 9-2320-363-10)

Engine off (TM 9-2320-363-10)

If equipped, Battery Disconnect Switch in OFF position (TM 9-2320-363-10), otherwise, disconnect battery cables (TM 9-2320-363-20-2)

Outside Door Mirror removed (TM 9-2320-363-20-2)

---

**NOTE**

The following procedure is for right side door ballistic glass and frame. Use same procedure for left side door ballistic glass and frame.

REMOVAL



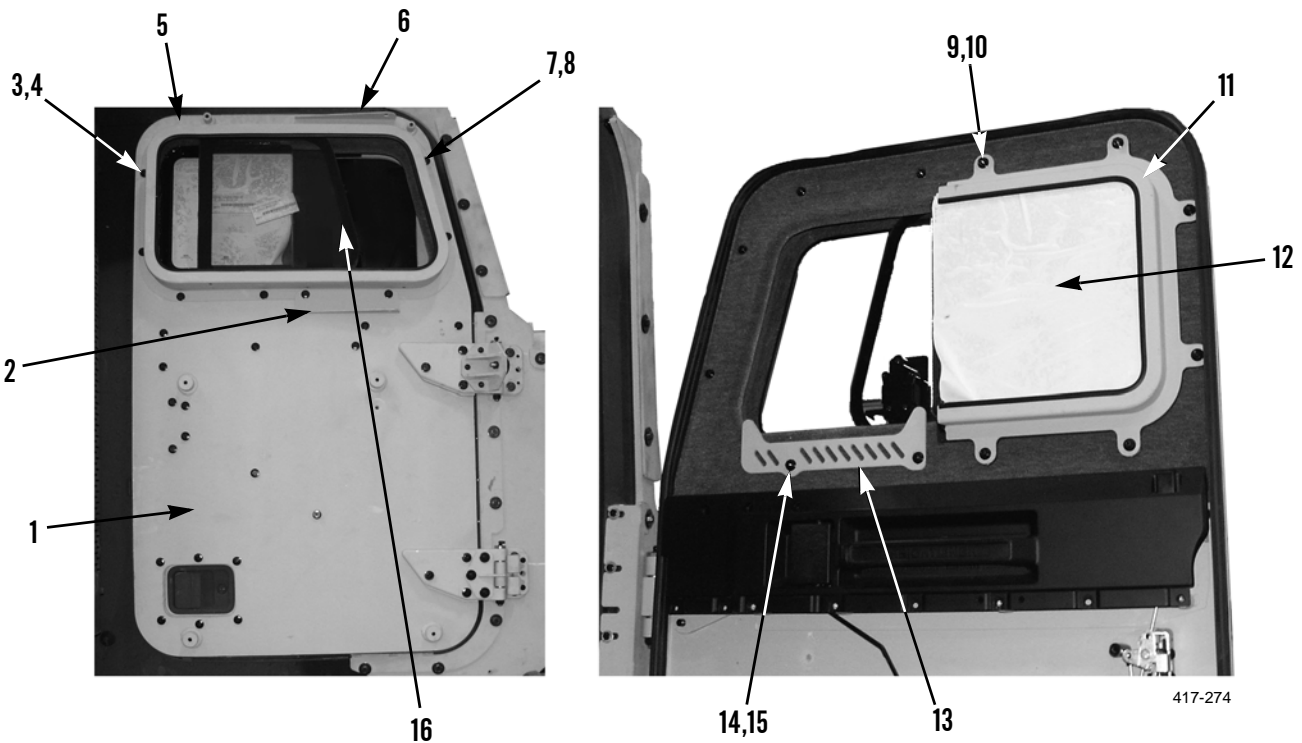
WARNING

Use extreme caution when handling heavy parts. Provide adequate support and use assistance during procedure. Failure to follow this warning may cause injury or death to personnel.

NOTE

Door ballistic glass and frame assembly weighs 151.8 lb (69 kg).

1. With assistance, remove six nuts (9), washers (10), bolts (3), and washers (4) while maintaining support for internal ballistic glass door frame (11) with ballistic glass (12).
2. With assistance, carefully remove internal ballistic glass door frame (11) with ballistic glass (12) from door (1).



3. With assistance, remove lower two nuts (14), washers (15), ballistic window stop (13), bolts (7), washers (8), and lower mirror support (2) while maintaining support for ballistic glass (16).
4. With assistance, remove upper two nuts (14), washers (15), bolts (7), washers (8), and upper mirror support (6) while maintaining support for ballistic glass (16).
5. With assistance, remove two remaining nuts (14), washers (15), bolts (7), and washers (8) while maintaining support for ballistic glass (16).
6. With assistance, carefully remove ballistic glass (16) from outside of door (1).



**CLEANING AND INSPECTION**

Clean and inspect all parts IAW *General Maintenance Instructions* (WP 0011 00).

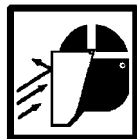
**INSTALLATION****WARNING**

- Use extreme caution when handling heavy parts. Provide adequate support and use assistance during procedure. Failure to follow this warning may cause injury or death to personnel.
- Use caution when handling window glass. Glass can break unexpectedly during removal/installation procedure. Wear face shield, apron, and gloves. Failure to follow this warning may cause injury to personnel.

**NOTE**

Door ballistic glass and frame assembly weighs 151.8 lb (69 kg).

1. With assistance, carefully install ballistic glass (16) from outside of door (1).
2. With assistance, install the two most forward facing washers (8), bolts (7), washers (15), and nuts (14) while maintaining support for ballistic glass (16).
3. With assistance, install upper mirror support (6) with upper two washers (8), bolts (7), washers (15), and nuts (14) while maintaining support for ballistic glass (16).
4. With assistance, install lower mirror support (2) with lower two remaining washers (8), bolts (7), ballistic window stop (13), washers (15), and nuts (14) while maintaining support for ballistic glass (16).

**WARNING**

Use caution when handling window glass. Glass can break unexpectedly during removal/installation procedure. Wear face shield, apron, and gloves. Failure to follow this warning may cause injury to personnel.

5. With assistance, carefully install internal ballistic glass door frame (11) with ballistic glass (12) to door (1).
6. With assistance, install six bolts (3), washers (4), washers (10), and nuts (9) while maintaining support for internal ballistic glass door frame (11) with ballistic glass (12).
7. Install outside mirror to door assembly. For the M915A3P1, M916A3P1, and M917A2P1, refer to TM 9-2320-302-20-2. For the M915A4P1, refer to TM 9-2320-303-24-1. For the M915A2P1, M916A1P1, M916A2P1, and M917A1P1, refer to TM 9-2320-363-20-2.

**END OF WORK PACKAGE**



---

**DOOR LATCH ADJUSTMENT**

**0016 00**

---

**THIS WORK PACKAGE COVERS**

Adjustment

---

**INITIAL SETUP**

**Maintenance Level**

Unit

**Tools and Special Tools**

Tool Kit, General Mechanic's (Item 8, WP 0033 00)

**Materials/Parts**

Rag, Wiping (Item 6, WP 0034 00)

**Equipment Conditions**

**(M915A3P1, M916A3P1, and M917A2P1)**

Vehicle parked on level ground (TM 9-2320-302-10)

Parking/Emergency Brake applied (TM 9-2320-302-10)

Engine off (TM 9-2320-302-10)

Battery Disconnect Switch in OFF position (TM 9-2320-302-10)

Door Panel removed (WP 0014 00)

**Equipment Conditions - Continued**

**(M915A4P1)**

Vehicle parked on level ground (TM 9-2320-303-10)

Parking/Emergency Brake applied (TM 9-2320-303-10)

Engine off (TM 9-2320-303-10)

Battery Disconnect Switch in OFF position (TM 9-2320-303-10)

Door Panel removed (WP 0014 00)

**(M915A2P1, M916A1P1, M916A2P1, and M917A1P1)**

Vehicle parked on level ground (TM 9-2320-363-10)

Parking/Emergency Brake applied (TM 9-2320-363-10)

Engine off (TM 9-2320-363-10)

If equipped, Battery Disconnect Switch in OFF position (TM 9-2320-363-10), otherwise, disconnect battery cables (TM 9-2320-363-20-2)

Door Panel removed (WP 0014 00)

---

**ADJUSTMENT****NOTE**

The latch can be centered in up/down direction by loosening three bolts (2). The latch can be centered in the in/out direction by loosening three bolts (4).

1. Loosen three bolts (2) and adjust latching mechanism (3) until striker is centered in the latching mechanism.

**NOTE**

Latch must be centered so that it contacts both the upper and lower dovetails on the striker mounting plate at approximately the same time.

2. Loosen three bolts (4) and adjust door latch bracket (1) until striker is centered in the latching mechanism.
3. Repeat steps 1 and 2 as required to ensure correct operation of latching mechanism.
4. Install door panel (WP 0014 00).



417-275

**END OF WORK PACKAGE**

---

**CAB SUPPORT REINFORCEMENT REPLACEMENT**

**0017 00**

---

**THIS WORK PACKAGE COVERS**

Removal, Cleaning and Inspection, Installation

---

**INITIAL SETUP**

**Maintenance Level**

Unit

**Tools and Special Tools**

Tool Kit, General Mechanic's (Item 8, WP 0033 00)

Shop Equipment, Common No. 1 (Item 6, WP 0033 00)

Device, Lifting (4,000-lb capacity)

**Materials/Parts**

Rag, Wiping (Item 6, WP 0034 00)

**References**

WP 0011 00

**Personnel Required**

Two

**Equipment Conditions**

**(M915A3P1, M916A3P1, and M917A2P1)**

Vehicle parked on level ground (TM 9-2320-302-10)

Parking/Emergency Brake applied (TM 9-2320-302-10)

Engine off (TM 9-2320-302-10)

Battery Disconnect Switch in OFF position (TM 9-2320-302-10)

Equipment air pressure relieved (TM 9-2320-302-10)

**Equipment Conditions - Continued**

**(M915A4P1)**

Vehicle parked on level ground (TM 9-2320-303-10)

Parking/Emergency Brake applied (TM 9-2320-303-10)

Engine off (TM 9-2320-303-10)

Battery Disconnect Switch in OFF position (TM 9-2320-303-10)

Equipment air pressure relieved (TM 9-2320-303-10)

**(M915A2P1, M916A1P1, M916A2P1, and M917A1P1)**

Vehicle parked on level ground (TM 9-2320-363-10)

Parking/Emergency Brake applied (TM 9-2320-363-10)

Engine off (TM 9-2320-363-10)

If equipped, Battery Disconnect Switch in OFF position (TM 9-2320-363-10), otherwise, disconnect battery cables (TM 9-2320-363-20-2)

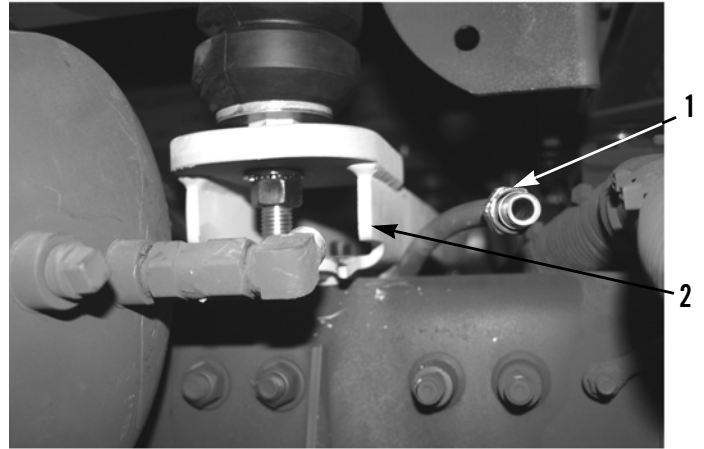
Equipment air pressure relieved (TM 9-2320-363-10)

---

**REMOVAL****WARNING**

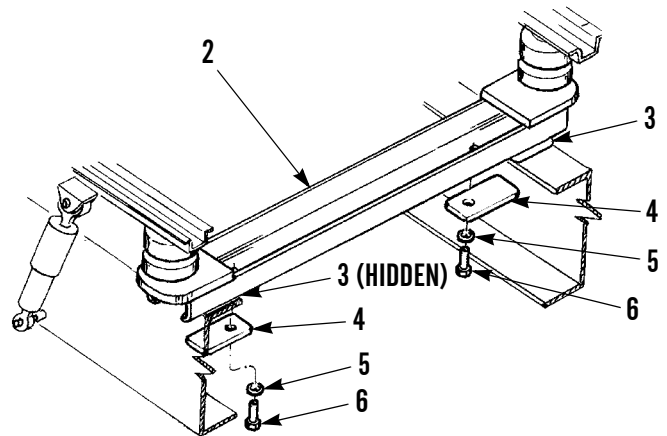
Use extreme caution when handling heavy parts. Provide adequate support and use assistance during procedure. Ensure that any lifting device used is in good condition and of suitable load capacity. Keep clear of heavy parts supported only by lifting device. Failure to follow this warning may cause injury or death to personnel.

1. Use lifting device to raise rear of cab enough to remove weight from cab support reinforcement (2).
2. After air pressure has been bled, disconnect air line (1) from rear end of air tank located under left side of the cab.



417-276

3. Remove two bolts (6), washers (5), clamp bars (4), and cab support reinforcement (2) from vehicle.
4. Remove two rubber insulators (3) from vehicle frame.



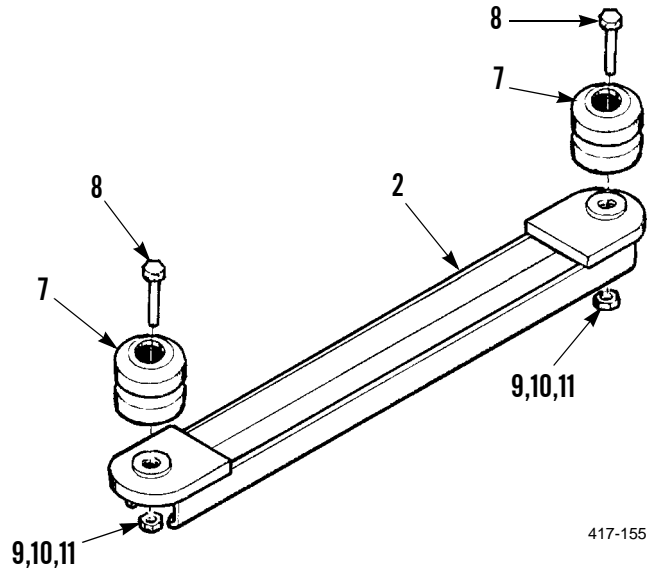
417-154

**CAB SUPPORT REINFORCEMENT REPLACEMENT - CONTINUED**

0017 00

**REMOVAL - CONTINUED**

- Remove two nuts (9), star washers (10), washers (11), bolts (8), and isolators (7) from cab support reinforcement (2).



417-155

**CLEANING AND INSPECTION**

Clean and inspect all parts IAW *General Maintenance Instructions* (WP 0011 00).

**INSTALLATION**

- Install two isolators (7), bolts (8), washers (11), star washers (10), and nuts (9) on cab support reinforcement (2).

**WARNING**

Use extreme caution when handling heavy parts. Provide adequate support and use assistance during procedure. Ensure that any lifting device used is in good condition and of suitable load capacity. Keep clear of heavy parts supported only by lifting device. Failure to follow this warning may cause injury or death to personnel.

- Use lifting device to raise rear of cab enough to install cab support reinforcement (2) on frame.
- Install two rubber insulators (3) on vehicle frame.
- Install cab support reinforcement (2) on rubber insulators (3).
- Install two clamp bars (4), washers (5), and bolts (6) on cab support reinforcement (2). Tighten to 120 ft-lb (160 Nm).
- Remove lifting device from vehicle.
- Connect air line (1) to air tank.

**END OF WORK PACKAGE**





---

**WHEEL ZONE DEFLECTOR REPLACEMENT**

**0018 00**

---

**THIS WORK PACKAGE COVERS**

Removal, Cleaning and Inspection, Installation

---

**INITIAL SETUP**

**Maintenance Level**

Unit

**Tools and Special Tools**

Tool Kit, General Mechanic's (Item 8, WP 0033 00)

Shop Equipment, Common No. 1 (Item 6, WP 0033 00)

Sling, Nylon (Item 7, WP 0033 00)

Device, Lifting (500-lb capacity)

**Materials/Parts**

Rag, Wiping (Item 6, WP 0034 00)

**References**

WP 001100

**Personnel Required**

Two

**Equipment Conditions**

**(M915A3P1, M916A3P1, and M917A2P1)**

Vehicle parked on level ground (TM 9-2320-302-10)

Parking/Emergency Brake applied (TM 9-2320-302-10)

**Equipment Conditions - Continued**

Engine off (TM 9-2320-302-10)

Battery Disconnect Switch in OFF position (TM 9-2320-302-10)

**(M915A4P1)**

Vehicle parked on level ground (TM 9-2320-303-10)

Parking/Emergency Brake applied (TM 9-2320-303-10)

Engine off (TM 9-2320-303-10)

Battery Disconnect Switch in OFF position (TM 9-2320-303-10)

**(M915A2P1, M916A1P1, M916A2P1, and M917A1P1)**

Vehicle parked on level ground (TM 9-2320-363-10)

Parking/Emergency Brake applied (TM 9-2320-363-10)

Engine off (TM 9-2320-363-10)

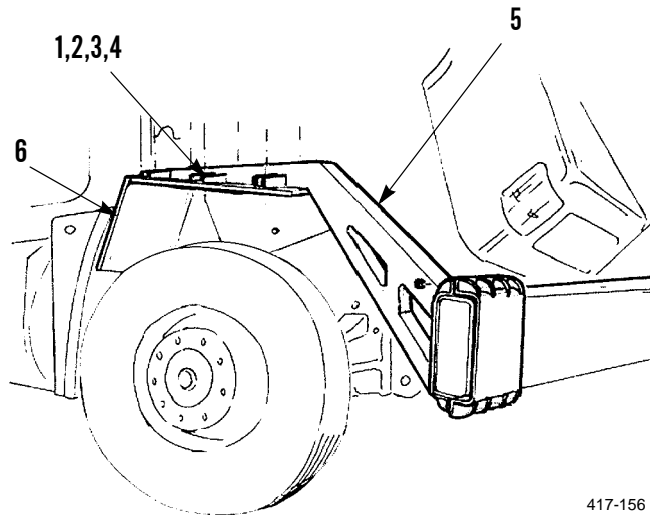
If equipped, Battery Disconnect Switch in OFF position (TM 9-2320-363-10), otherwise, disconnect battery cables (TM 9-2320-363-20-2)

---

**REMOVAL****WARNING**

Use extreme caution when handling heavy parts. Provide adequate support and use assistance during procedure. Failure to follow this warning may cause injury or death to personnel.

1. With assistance, remove six nuts (1), bolts (4), washers (2), star washers (3), and wheel zone deflector (6) from wheel zone deflector support arm (5).



417-156

2. Attach lifting device and sling to wheel zone deflector support arm (5).

**WARNING**

Use extreme caution when handling heavy parts. Provide adequate support and use assistance during procedure. Ensure that any lifting device used is in good condition and of suitable load capacity. Keep clear of heavy parts supported only by lifting device. Failure to follow this warning may cause injury or death to personnel.

**NOTE**

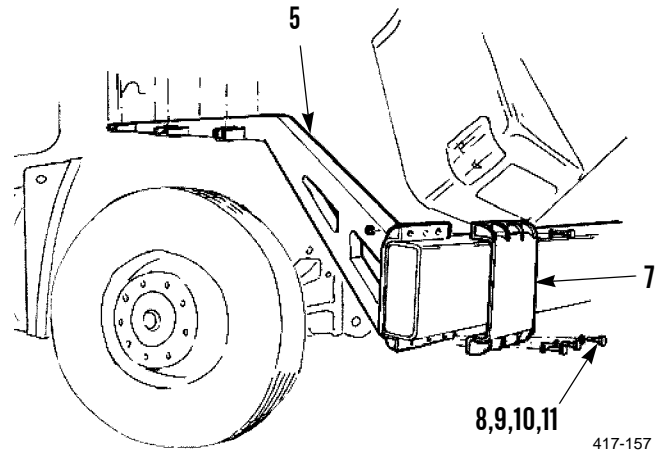
Door assembly weighs 368 lb (167 kg).

**WHEEL ZONE DEFLECTOR REPLACEMENT - CONTINUED**

0018 00

**REMOVAL - CONTINUED**

3. Using lifting device, remove six nuts (8), bolts (9), washers (10), star washers (11), bracket (7), and wheel zone deflector support arm (5) from bumper.
4. Remove sling and lifting device from wheel housing (5).

**CLEANING AND INSPECTION**

Clean and inspect all parts IAW *General Maintenance Instructions* (WP 0011 00).

**INSTALLATION**

1. Attach sling and lifting device to wheel zone deflector support arm (5).

**WARNING**

Use extreme caution when handling heavy parts. Provide adequate support and use assistance during procedure. Ensure that any lifting device used is in good condition and of suitable load capacity. Keep clear of heavy parts supported only by lifting device. Failure to follow this warning may cause injury or death to personnel.

**NOTE**

- Door assembly weighs 368 lb (167 kg).
  - Align wheel zone deflector support arm and bracket to allow wheel zone deflector to clear truck hood.
2. Using lifting device, install wheel zone deflector support arm (5), bracket (7), six washers (10), star washers (11), bolts (9), and nuts (8) on bumper.

**WARNING**

Use extreme caution when handling heavy parts. Provide adequate support and use assistance during procedure. Failure to follow this warning may cause injury or death to personnel.

3. With assistance, install wheel zone deflector (6), six washers (2), star washers (3), bolts (4), and nuts (1) on wheel zone deflector support arm (5).

**END OF WORK PACKAGE**



**FLOOR ARMOR REPLACEMENT**

**0019 00**

**THIS WORK PACKAGE COVERS**

Removal, Cleaning and Inspection, Installation

**INITIAL SETUP**

**Maintenance Level**

Unit

**Tools and Special Tools**

Tool Kit, General Mechanic's (Item 8, WP 0033 00)

**Materials/Parts**

Rag, Wiping (Item 6, WP 0034 00)

**References**

WP 0011 00

**Personnel Required**

Two

**Equipment Conditions**

**(M915A3P1, M916A3P1, and M917A2P1)**

Vehicle parked on level ground (TM 9-2320-302-10)

Parking/Emergency Brake applied (TM 9-2320-302-10)

Engine off (TM 9-2320-302-10)

Battery Disconnect Switch in OFF position (TM 9-2320-302-10)

Right and Left Seats removed (TM 9-2320-302-20)

Transmission Shift Tower removed (TM 9-2320-302-20)

Fire Extinguisher Bracket removed (TM 9-2320-302-20)

If equipped, Arctic Heater Box removed (TM 9-2320-302-20)

Rear Armor removed (WP 0023 00)

**Equipment Conditions - Continued**

**(M915A4P1)**

Vehicle parked on level ground (TM 9-2320-303-10)

Parking/Emergency Brake applied (TM 9-2320-303-10)

Engine off (TM 9-2320-303-10)

Battery Disconnect Switch in OFF position (TM 9-2320-303-10)

Right and Left Seats removed (TM 9-2320-303-24-1)

Transmission Shift Tower removed (TM 9-2320-303-24-1)

Fire Extinguisher Bracket removed (TM 9-2320-303-24-1)

If equipped, Arctic Heater Box removed (TM 9-2320-303-24-1)

Rear Armor removed (WP 0023 00)

**(M915A2P1, M916A1P1, M916A2P1, and M917A1P1)**

Vehicle parked on level ground (TM 9-2320-363-10)

Parking/Emergency Brake applied (TM 9-2320-363-10)

Engine off (TM 9-2320-363-10)

If equipped, Battery Disconnect Switch in OFF position (TM 9-2320-363-10), otherwise, disconnect battery cables (TM 9-2320-363-20-2)

Right and Left Seats removed (TM 9-2320-363-20-2)

Transmission Shift Tower removed (TM 9-2320-363-20-2)

Fire Extinguisher Bracket removed (TM 9-2320-363-20-2)

If equipped, Arctic Heater Box removed (TM 9-2320-363-20-2)

Rear Armor removed (WP 0023 00)

**FLOOR ARMOR REPLACEMENT - CONTINUED****0019 00****REMOVAL**

1. Remove left seat base (12) from left floor armor (11).
2. Remove seven bolts (3), washers (4), bracket (1), and angle bracket (2) from left floor armor (11).
3. Remove bolt (5) and washer (6) from center floor armor (10).
4. Remove eight bolts (7), washers (8), and angle bracket (9) from center floor armor (10).

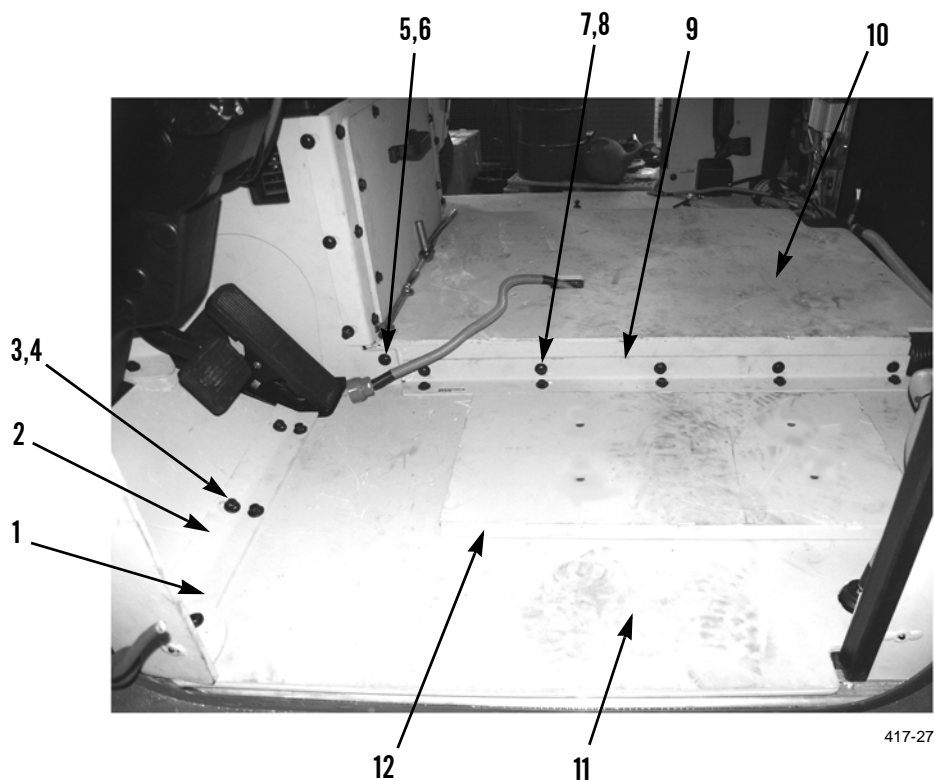
**WARNING**

Use extreme caution when handling heavy parts. Provide adequate support and use assistance during procedure. Failure to follow this warning may cause injury or death to personnel.

**NOTE**

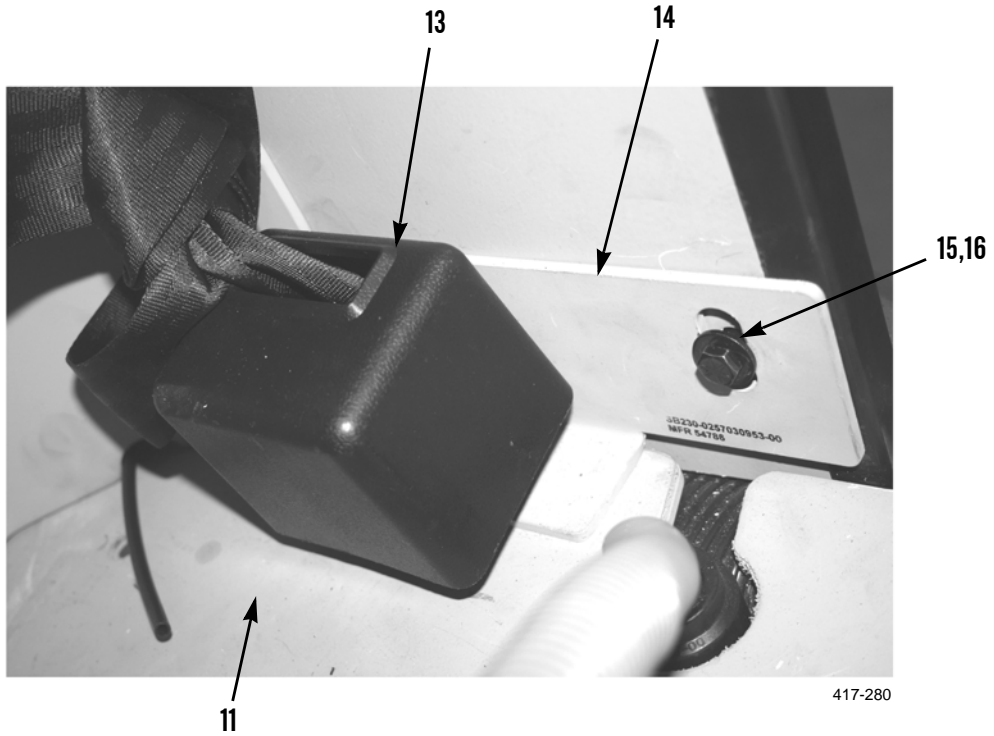
Left floor armor weighs 72 lb (33 kg) estimated.

5. With assistance, remove left floor armor (11) from cab.



**REMOVAL - CONTINUED**

6. Remove three bolts (15), washers (16), bracket (14), and restraint retractor (13) from left floor armor (11).

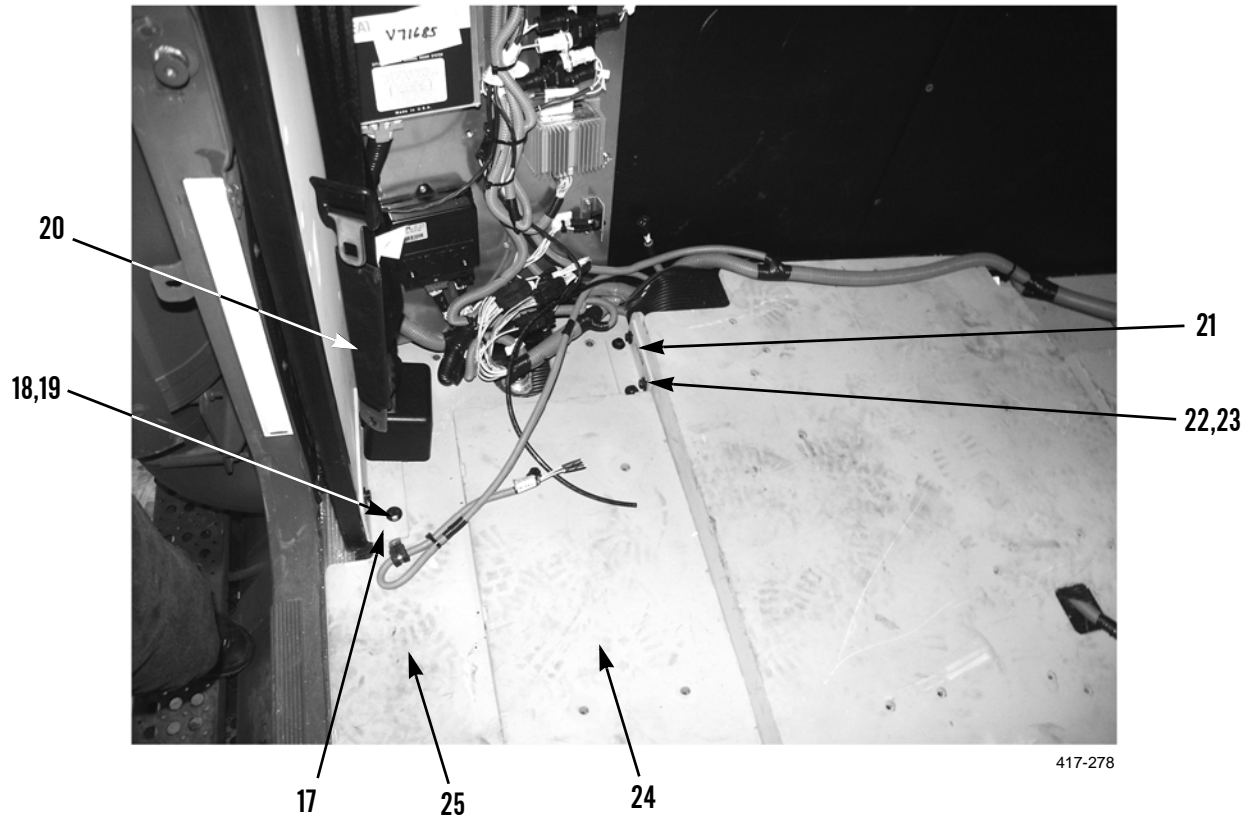


**FLOOR ARMOR REPLACEMENT - CONTINUED**

0019 00

**REMOVAL - CONTINUED**

7. Remove right seat base (24) from right floor armor (25).
8. Remove three bolts (18), washers (19), bracket (17), and restraint retractor (20) from right floor armor (25).
9. Remove four bolts (22), washers (23), and bracket (21) from right floor armor (25).





**REMOVAL - CONTINUED**

10. Remove three bolts (27), washers (28), and bracket (26) from right floor armor (25).
11. Remove bolt (29) and washer (30) from center floor armor (10).
12. Remove six bolts (32), washers (33), and angle bracket (31) from right floor armor (25).

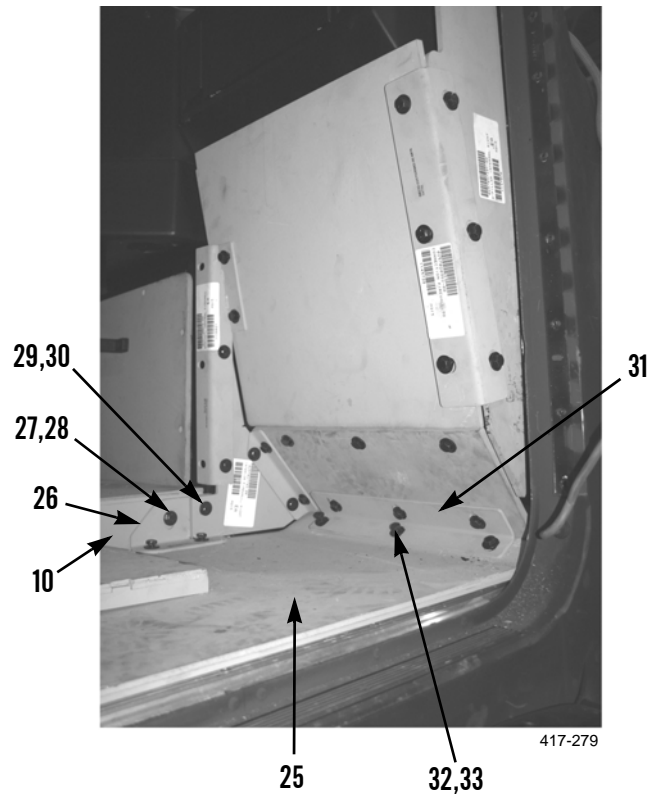
**WARNING**

Use extreme caution when handling heavy parts. Provide adequate support and use assistance during procedure. Failure to follow this warning may cause injury or death to personnel.

**NOTE**

Floor armor weighs 72 lb (33 kg) each estimated.

13. With assistance, remove center floor armor (10) then right floor armor (25) from cab.

**CLEANING AND INSPECTION**

Clean and inspect all parts IAW *General Maintenance Instructions* (WP 0011 00).

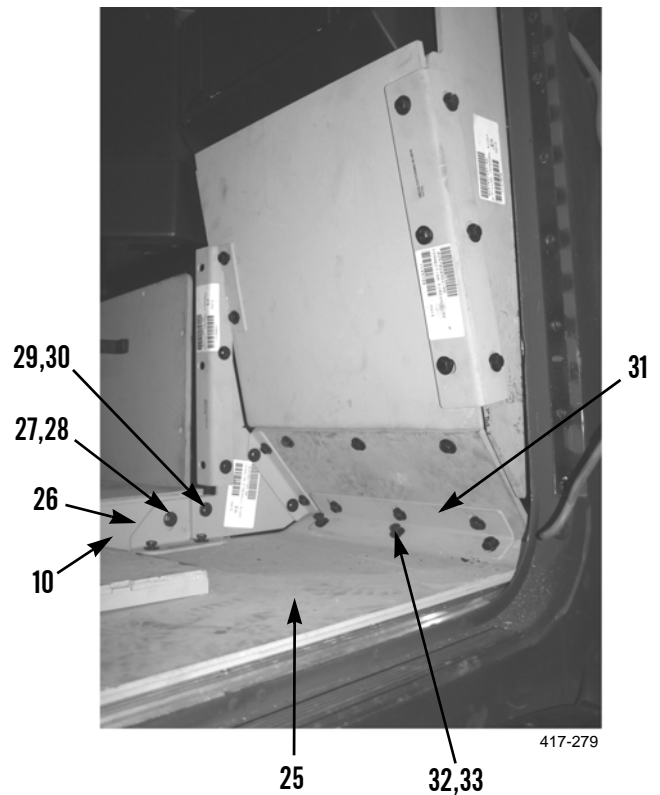
**INSTALLATION****WARNING**

Use extreme caution when handling heavy parts. Provide adequate support and use assistance during procedure. Failure to follow this warning may cause injury or death to personnel.

**NOTE**

Floor armor weighs 72 lb (33 kg) each estimated.

1. With assistance, install right floor armor (25) then center floor armor (10) on cab.
2. Install angle bracket (21), six washers (33), and bolts (32) on right floor armor (25).
3. Install washer (30) and bolt (29) on center floor armor (10).
4. Install bracket (26), three washers (28), and bolts (27) on right floor armor (25).

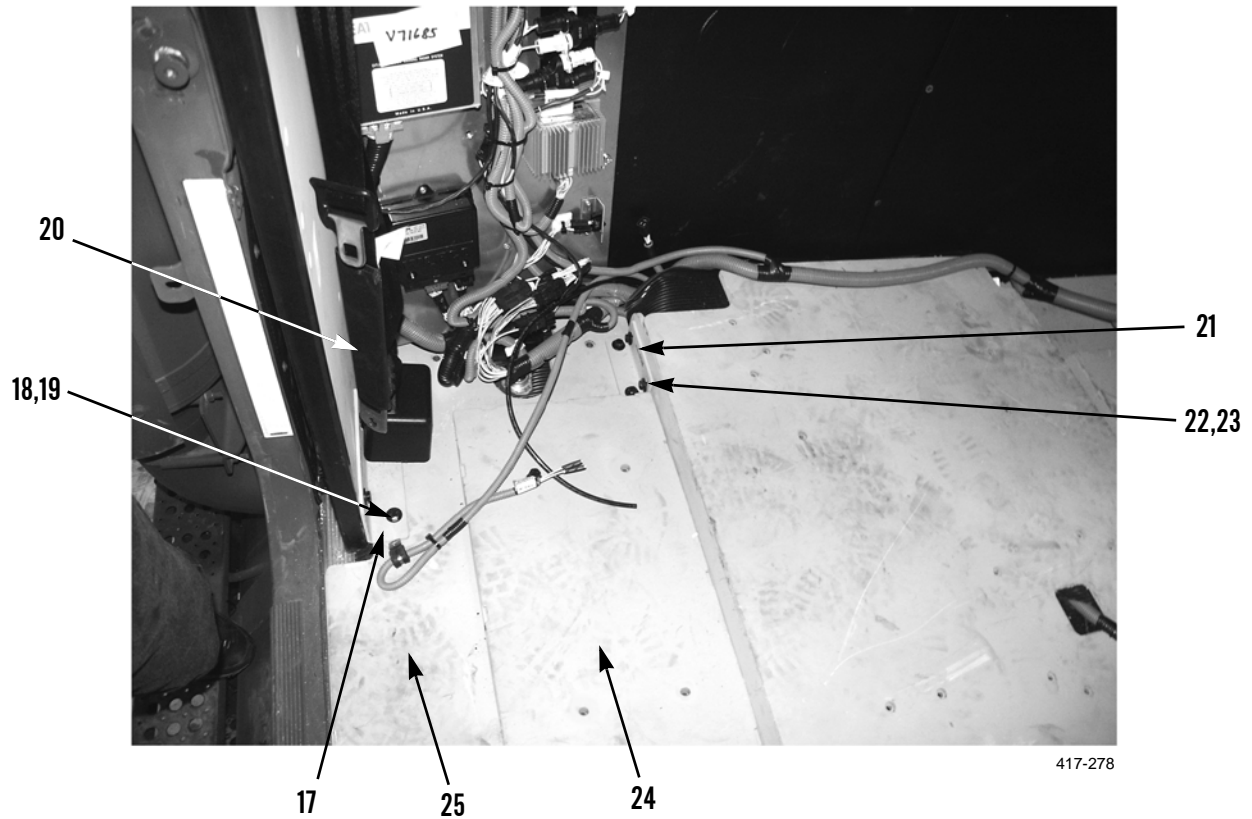


**FLOOR ARMOR REPLACEMENT - CONTINUED**

0019 00

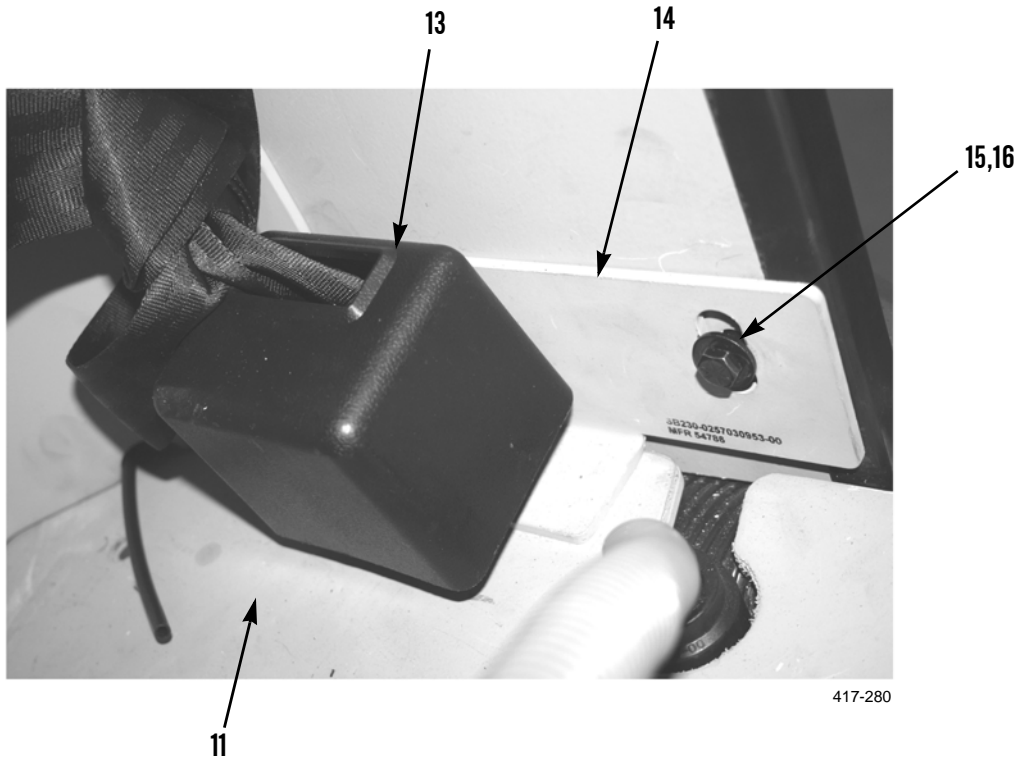
**INSTALLATION - CONTINUED**

5. Install bracket (21), four washers (23), and bolts (22) on right floor armor (25).
6. Install bracket (17), restraint retractor (20), three washers (19), and bolts (18) on right floor armor (25).
7. Install right seat base (24) on right floor armor (25).



**INSTALLATION - CONTINUED**

8. Install bracket (14), restraint retractor (13), three washers (16), and bolts (15) on left floor armor (11).



## INSTALLATION - CONTINUED

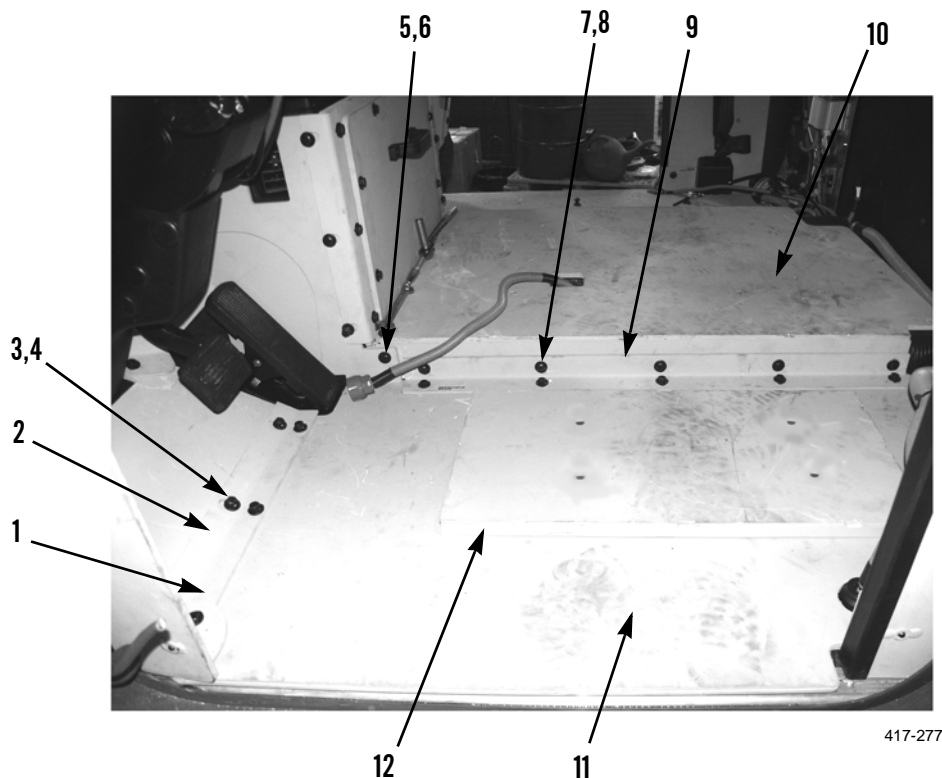
**WARNING**

Use extreme caution when handling heavy parts. Provide adequate support and use assistance during procedure. Failure to follow this warning may cause injury or death to personnel.

**NOTE**

Left floor armor weighs 72 lb (33 kg) estimated.

9. With assistance, install left floor (11) armor on cab.
10. Install angle bracket (9), eight washers (8), and bolts (7) on center floor armor (10).
11. Install washer (6) and bolt (5) on center floor armor (10).
12. Install angle bracket (2), bracket (1), seven washers (4), and bolts (3) on left floor armor (11).
13. Install left seat base (12) on left floor armor (11).



14. Install rear armor (WP 0023 00).
15. If removed, install arctic heater box. For the M915A3P1, M916A3P1, and M917A2P1, refer to TM 9-2320-302-20-2. For the M915A4P1, refer to TM 9-2320-303-24-1. For the M915A2P1, M916A1P1, M916A2P1, and M917A1P1, refer to TM 9-2320-363-20-2.

---

**FLOOR ARMOR REPLACEMENT - CONTINUED**

---

**0019 00**

***INSTALLATION - CONTINUED***

16. Install fire extinguisher bracket. For the M915A3P1, M916A3P1, and M917A2P1, refer to TM 9-2320-302-202. For the M915A4P1, refer to TM 9-2320-303-24-1. For the M915A2P1, M916A1P1, M916A2P1, and M917A1P1, refer to TM 9-2320-363-20-2.
17. Install transmission shift tower. For the M915A3P1, M916A3P1, and M917A2P1, refer to TM 9-2320-302-20-2. For the M915A4P1, refer to TM 9-2320-303-24-1. For the M915A2P1, M916A1P1, M916A2P1, and M917A1P1, refer to TM 9-2320-363-20-2.
18. Install right and left seats. For the M915A3P1, M916A3P1, and M917A2P1, refer to TM 9-2320-302-20-2. For the M915A4P1, refer to TM 9-2320-303-24-1. For the M915A2P1, M916A1P1, M916A2P1, and M917A1P1, refer to TM 9-2320-363-20-2.

**END OF WORK PACKAGE**

**RIGHT SIDE ARMOR REPLACEMENT**

**0020 00**

**THIS WORK PACKAGE COVERS**

Removal, Cleaning and Inspection, Installation

**INITIAL SETUP**

**Maintenance Level**

Unit

**Tools and Special Tools**

Tool Kit, General Mechanic's (Item 8, WP 0033 00)

**Materials/Parts**

Rag, Wiping (Item 6, WP 0034 00)

**References**

WP 0011 00

**Personnel Required**

Two

**Equipment Conditions**

**(M915A3P1, M916A3P1, and M917A2P1)**

Vehicle parked on level ground (TM 9-2320-302-10)

Parking/Emergency Brake applied (TM 9-2320-302-10)

Engine off (TM 9-2320-302-10)

Battery Disconnect Switch in OFF position (TM 9-2320-302-10)

Right Seat removed (TM 9-2320-302-20-2)

Firewall Armor removed (WP 0026 00)

If equipped, Collision Warning System Side Sensor Display removed (TM 9-2320-302-20-2)

Interior Light Unit removed (TM 9-2320-302-20-2)

**Equipment Conditions - Continued**

**(M915A4P1)**

Vehicle parked on level ground (TM 9-2320-303-10)

Parking/Emergency Brake applied (TM 9-2320-303-10)

Engine off (TM 9-2320-303-10)

Battery Disconnect Switch in OFF position (TM 9-2320-303-10)

Right Seat removed (TM 9-2320-303-24-1)

Firewall Armor removed (WP 0026 00)

If equipped, Collision Warning System Side Sensor Display removed (TM 9-2320-303-24-1)

Interior Light Unit removed (TM 9-2320-303-24-1)

**(M915A2P1, M916A1P1, M916A2P1, and M917A1P1)**

Vehicle parked on level ground (TM 9-2320-363-10)

Parking/Emergency Brake applied (TM 9-2320-363-10)

Engine off (TM 9-2320-363-10)

If equipped, Battery Disconnect Switch in OFF position (TM 9-2320-363-10), otherwise, disconnect battery cables (TM 9-2320-363-20-2)

Right Seat removed (TM 9-2320-363-20-2)

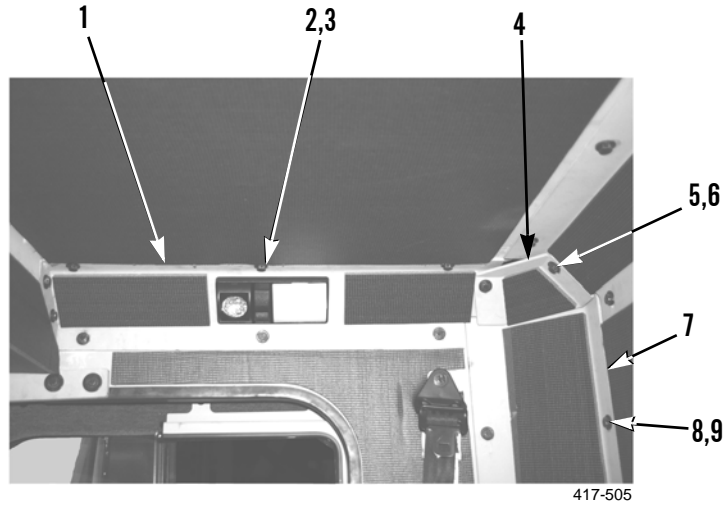
Firewall Armor removed (WP 0026 00)

If equipped, Collision Warning System Side Sensor Display removed (TM 9-2320-363-20-2)

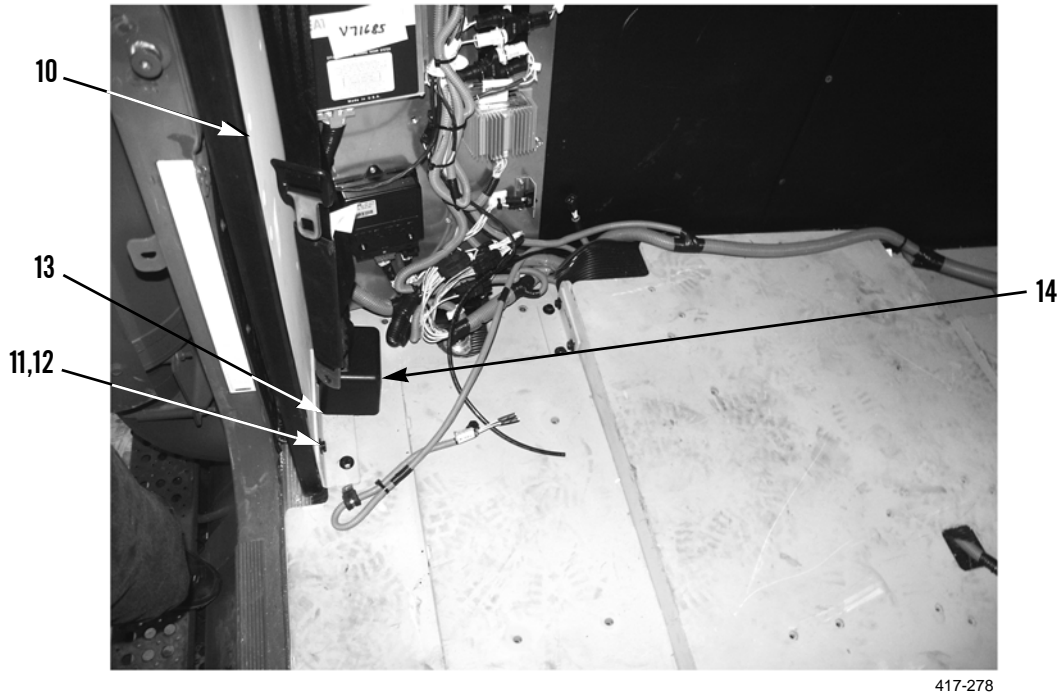
Interior Light Unit removed (TM 9-2320-363-20-2)

**REMOVAL**

1. Remove two bolts (5), washers (6), and right rear corner (4) from right rear B-pillar (7).
2. Remove eight bolts (8), washers (9), and right rear B-pillar (7) from right side armor (10).
3. Remove eight bolts (2), washers (3), and right rear roof overlap (1) from top of right side armor (10).



4. Remove four bolts (11), washers (12), restraint retractor (14), and bracket (13) from right side armor (10).



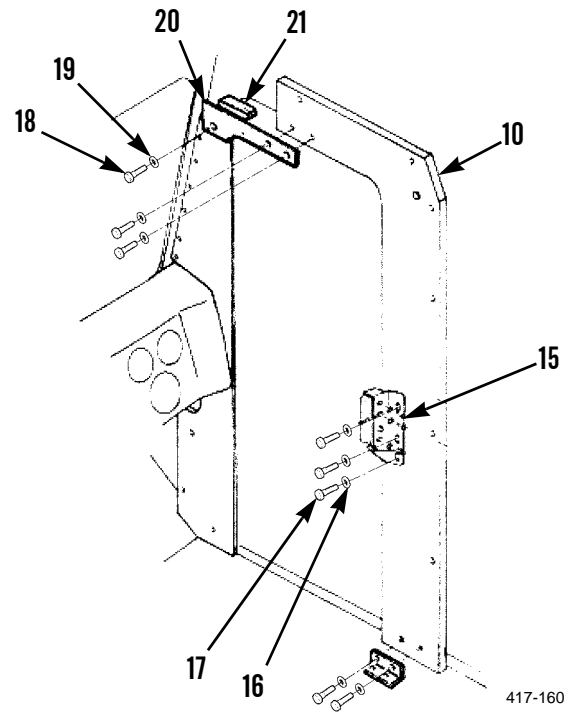


**RIGHT SIDE ARMOR REPLACEMENT - CONTINUED**

0020 00

**REMOVAL - CONTINUED**

5. Remove three bolts (17), washers (16), and latch (15) from right side armor (10).
6. Remove three bolts (18), washers (19), bracket (20), and spacer (21) from right side armor (10).

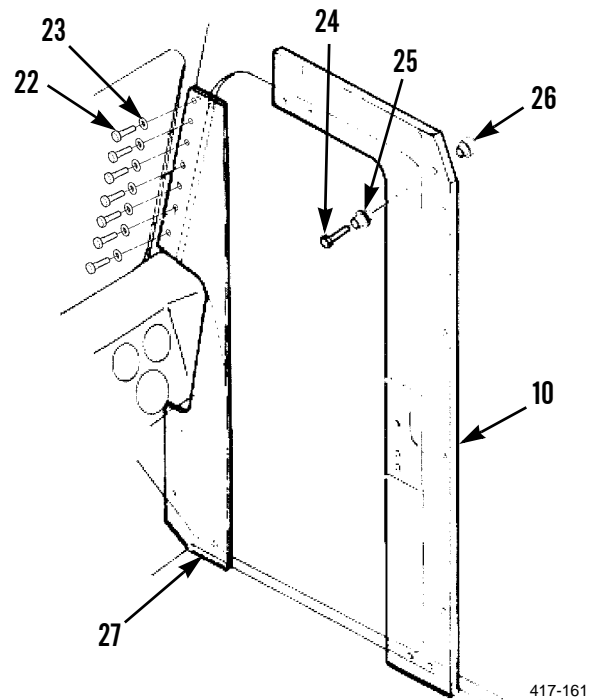


**REMOVAL - CONTINUED****WARNING**

Use extreme caution when handling heavy parts. Provide adequate support and use assistance during procedure. Failure to follow this warning may cause injury or death to personnel.

**NOTE**

- Right side armor weighs 70 lb (32 kg) estimated.
  - Right A-pillar armor weighs 40 lb (18 kg) estimated.
7. With assistance, remove seat belt bolt (24), bushing (26), bushing (25), and right side armor (10) from vehicle.
  8. With assistance, remove seven bolts (22), washers (23), and right A-pillar armor (27) from vehicle.

**CLEANING AND INSPECTION**

Clean and inspect all parts IAW *General Maintenance Instructions* (WP 0011 00).

**INSTALLATION****WARNING**

Use extreme caution when handling heavy parts. Provide adequate support and use assistance during procedure. Failure to follow this warning may cause injury or death to personnel.

**NOTE**

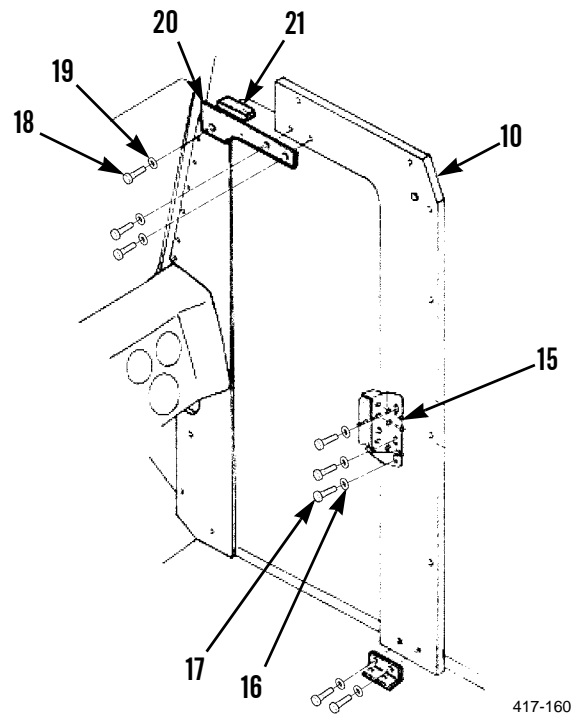
- Right side armor weighs 70 lb (32 kg) estimated.
  - Right A-pillar armor weighs 40 lb (18 kg) estimated.
1. With assistance, install right A-pillar armor (27), seven washers (23), and bolts (22) on vehicle.
  2. With assistance, install right side armor (10), bushing (26), bushing (25), and seat belt bolt (24) on vehicle.

**RIGHT SIDE ARMOR REPLACEMENT - CONTINUED**

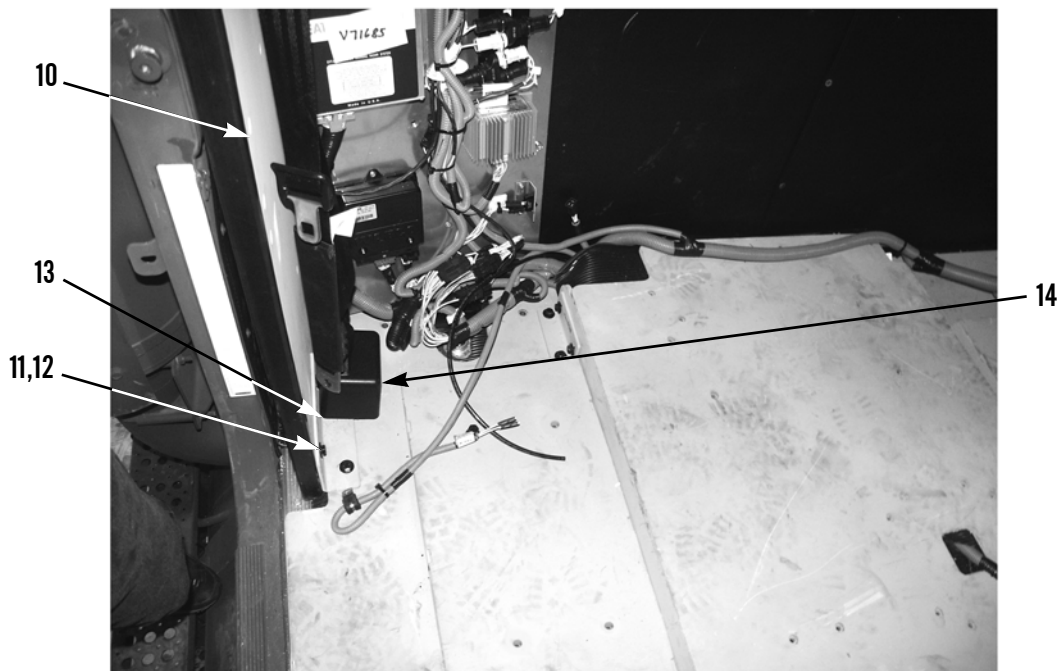
0020 00

**INSTALLATION - CONTINUED**

3. Install spacer (21), bracket (20), three washers (19), and bolts (18) on right side armor (10).
4. Install latch (15), three washers (16), and bolts (17) on right side armor (10).

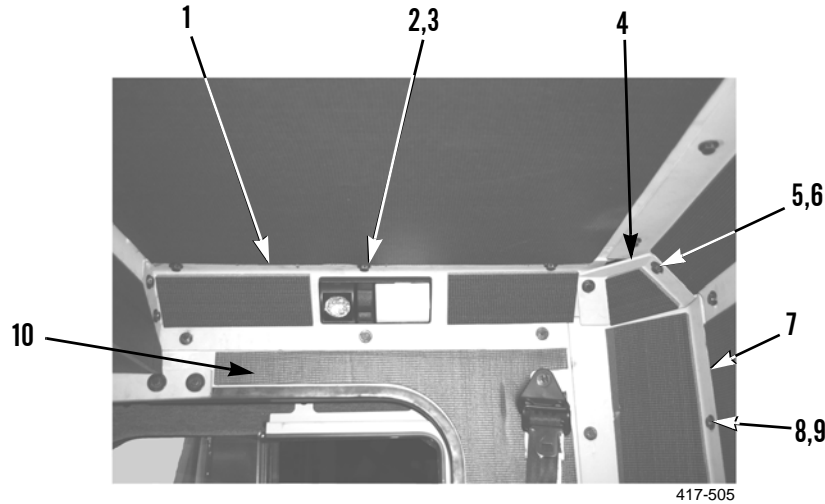


5. Install bracket (13), restraint retractor (14), four washers (12), and bolts (11) on right side armor (10).



**INSTALLATION - CONTINUED**

6. Install right rear roof overlap (1), eight washers (3), and bolts (2) on top of right side armor (10).
7. Install right rear B-pillar (7), eight washers (9), and bolts (8) on right side armor (10).
8. Install right rear corner (4), two washers (6), and bolts (5) on right rear B-pillar (7).



9. Install firewall armor (WP 0026 00).
10. Install right seat. For the M915A3P1, M916A3P1, and M917A2P1, refer to TM 9-2320-302-20-2. For the M915A4P1, refer to TM 9-2320-303-24-1. For the M915A2P1, M916A1P1, M916A2P1, and M917A1P1, refer to TM 9-2320-363-20-2.
11. If removed, Install collision warning system side sensor display. For the M915A3P1, M916A3P1, and M917A2P1, refer to TM 9-2320-302-20-2. For the M915A4P1, refer to TM 9-2320-303-24. For the M915A2P1, M916A1P1, M916A2P1, and M917A1P1, refer to TM 9-2320-363-20-2.
12. Install interior light unit. For the M915A3P1, M916A3P1, and M917A2P1, refer to TM 9-2320-302-20-2. For the M915A4P1, refer to TM 9-2320-303-24-1. For the M915A2P1, M916A1P1, M916A2P1, and M917A1P1, refer to TM 9-2320-363-20-2.

**END OF WORK PACKAGE**

---

**LEFT SIDE ARMOR REPLACEMENT**

**0021 00**

---

**THIS WORK PACKAGE COVERS**

Removal, Cleaning and Inspection, Installation

---

**INITIAL SETUP**

**Maintenance Level**

Unit

**Tools and Special Tools**

Tool Kit, General Mechanic's (Item 8, WP 0033 00)

**Materials/Parts**

Rag, Wiping (Item 6, WP 0034 00)

**References**

WP 0011 00

**Personnel Required**

Two

**Equipment Conditions**

**(M915A3P1, M916A3P1, and M917A2P1)**

Vehicle parked on level ground (TM 9-2320-302-10)

Parking/Emergency Brake applied (TM 9-2320-302-10)

Engine off (TM 9-2320-302-10)

Battery Disconnect Switch in OFF position (TM 9-2320-302-10)

Left Seat removed (TM 9-2320-302-20-2)

Firewall Armor removed (WP 0026 00)

Interior Light Unit removed (TM 9-2320-302-20-2)

**Equipment Conditions - Continued**

**(M915A4P1)**

Vehicle parked on level ground (TM 9-2320-303-10)

Parking/Emergency Brake applied (TM 9-2320-303-10)

Engine off (TM 9-2320-303-10)

Battery Disconnect Switch in OFF position (TM 9-2320-303-10)

Left Seat removed (TM 9-2320-303-24-1)

Firewall Armor removed (WP 0026 00)

Interior Light Unit removed (TM 9-2320-303-24-1)

**(M915A2P1, M916A1P1, M916A2P1, and M917A1P1)**

Vehicle parked on level ground (TM 9-2320-363-10)

Parking/Emergency Brake applied (TM 9-2320-363-10)

Engine off (TM 9-2320-363-10)

If equipped, Battery Disconnect Switch in OFF position (TM 9-2320-363-10), otherwise, disconnect battery cables (TM 9-2320-363-20-2)

Left Seat removed (TM 9-2320-363-20-2)

Firewall Armor removed (WP 0026 00)

Interior Light Unit removed (TM 9-2320-363-20-2)

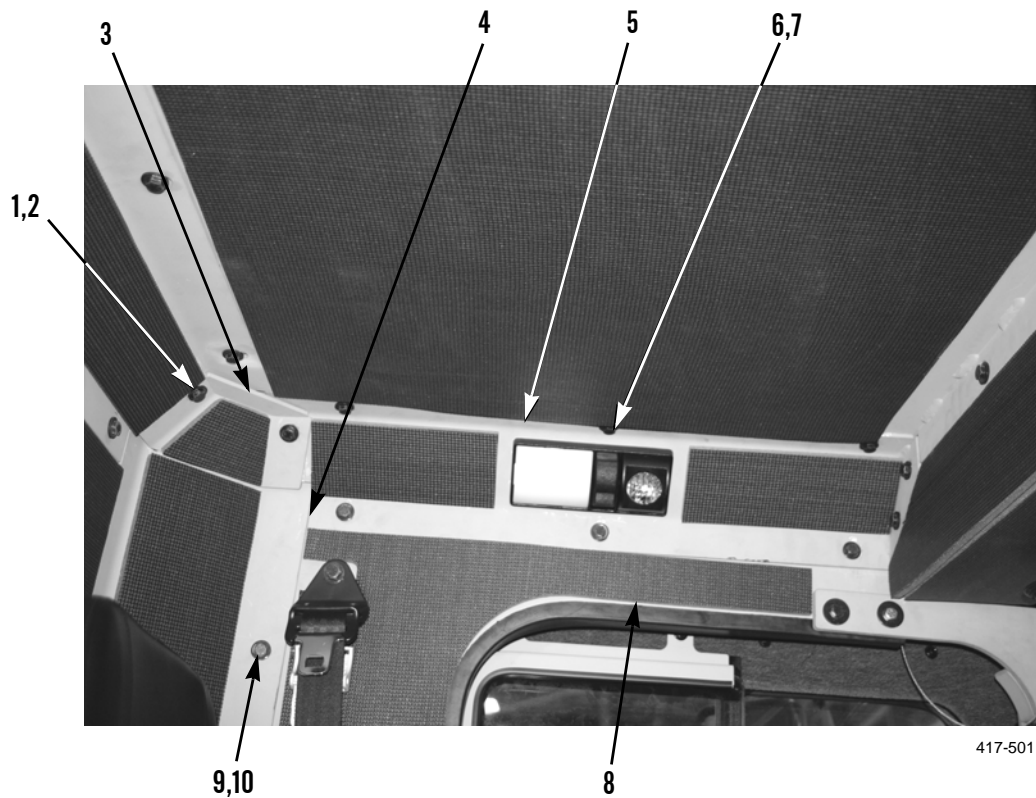
---

**LEFT SIDE ARMOR REPLACEMENT - CONTINUED**

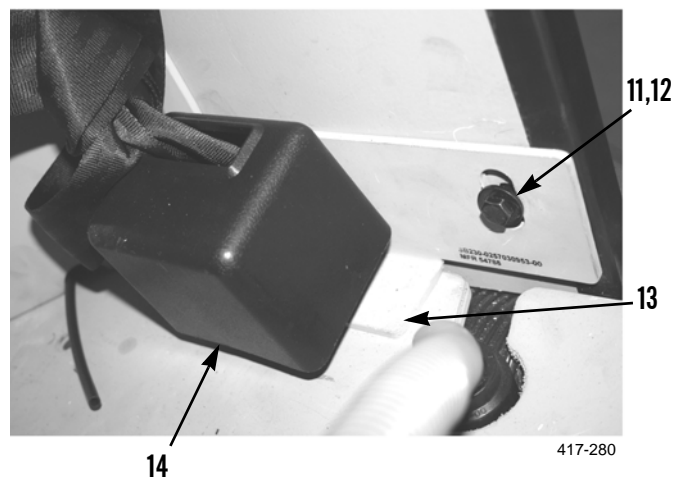
0021 00

**REMOVAL**

1. Remove two bolts (1), washers (2), and left rear corner (3) from left rear B-pillar (4).
2. Remove eight bolts (9), washers (10), and left rear B-pillar (4) from left side armor (8).
3. Remove eight bolts (6), washers (7), and left rear roof overlap (5) from top of left side armor (8).



4. Remove three bolts (11), washers (12), restraint retractor (14), and bracket (13) from left side armor (8).

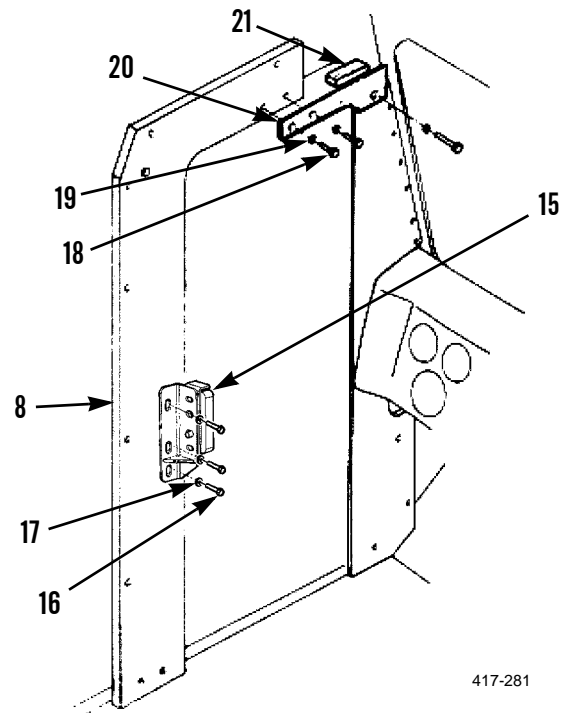


**LEFT SIDE ARMOR REPLACEMENT - CONTINUED**

0021 00

**REMOVAL - CONTINUED**

5. Remove three bolts (16), washers (17), and latch (15) from left side armor (8).
6. Remove four bolts (18), washers (19), bracket (20), and spacer (21) from left side armor (8).



417-281

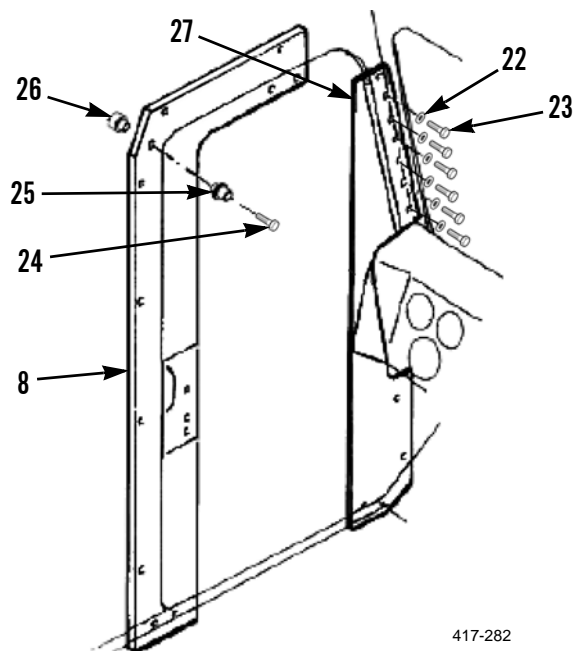
**REMOVAL - CONTINUED****WARNING**

Use extreme caution when handling heavy parts. Provide adequate support and use assistance during procedure. Failure to follow this warning may cause injury or death to personnel.

**NOTE**

- Left side armor weighs 70 lb (32 kg) estimated.
- Left A-pillar armor weighs 40 lb (18 kg) estimated.

7. With assistance, remove seat belt bolt (24), bushing (26), bushing (25), and left side armor (8) from vehicle.
8. With assistance, remove six bolts (23), washers (22), and left A-pillar armor (27) from vehicle.



417-282

**CLEANING AND INSPECTION**

Clean and inspect all parts IAW *General Maintenance Instructions* (WP 0011 00).

**INSTALLATION****WARNING**

Use extreme caution when handling heavy parts. Provide adequate support and use assistance during procedure. Failure to follow this warning may cause injury or death to personnel.

**NOTE**

- Left side armor weighs 70 lb (32 kg) estimated.
- Left A-pillar armor weighs 40 lb (18 kg) estimated.

1. With assistance, install left A-pillar armor (27), six washers (22), and bolts (23) on vehicle.
2. With assistance, install left side armor (8), bushing (26), bushing (25), and seat belt bolt (24) on vehicle.

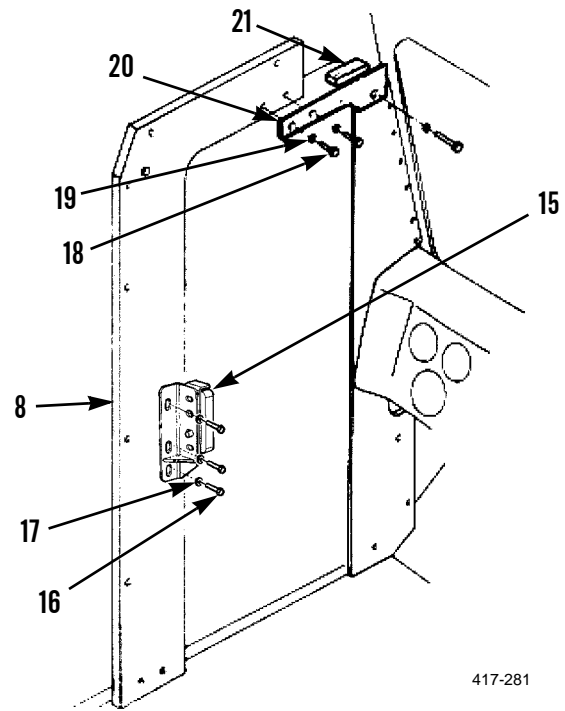


**LEFT SIDE ARMOR REPLACEMENT - CONTINUED**

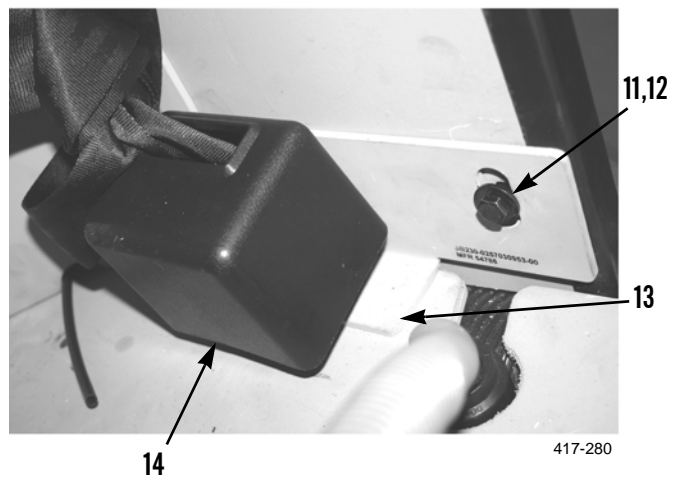
0021 00

**INSTALLATION - CONTINUED**

3. Install spacer (21), bracket (20), four washers (19), and bolts (18) on left side armor (8).
4. Install latch (15), three washers (17), and bolts (16) on left side armor (8).

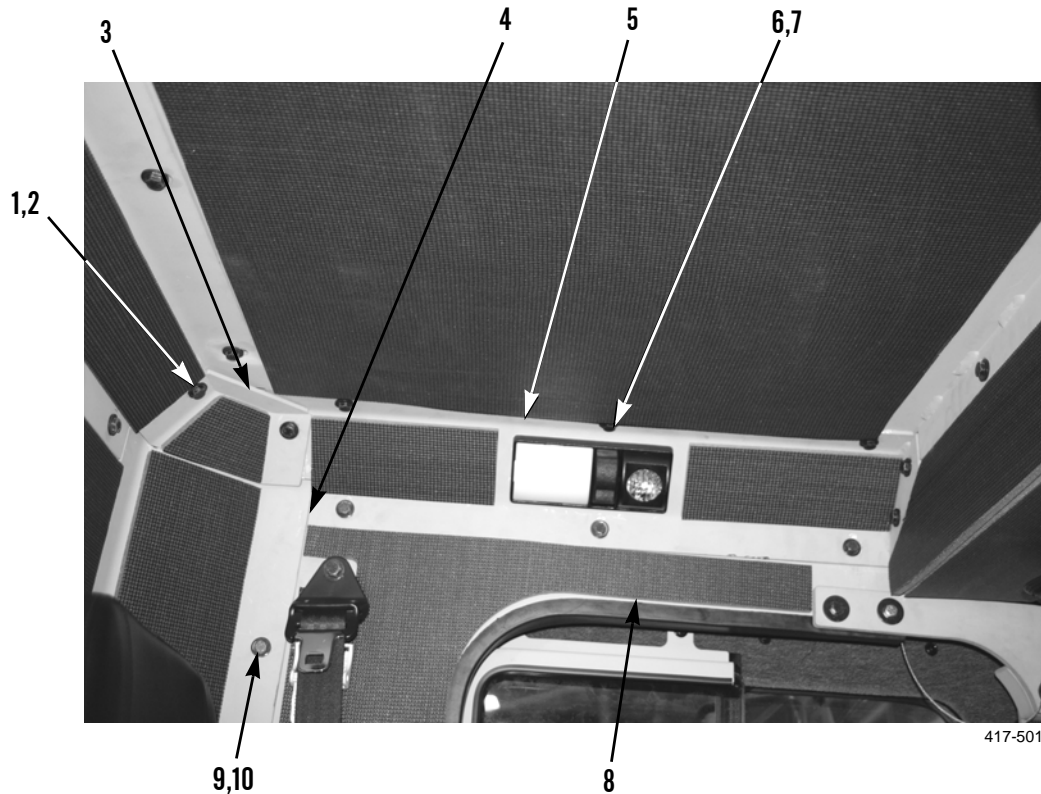


5. Install bracket (13), restraint retractor (14), three washers (12), and bolts (11) on left side armor (8).



**LEFT SIDE ARMOR REPLACEMENT - CONTINUED****0021 00****INSTALLATION - CONTINUED**

6. Install left rear roof overlap (5), eight washers (7), and bolts (6) on top of left side armor (8).
7. Install left rear B-pillar (4), eight washers (10), and bolts (9) on left side armor (8).
8. Install left rear corner (3), two washers (2), and bolts (1) on left rear B-pillar (4).



9. Install firewall armor (WP 0026 00).
10. Install left seat. For the M915A3P1, M916A3P1, and M917A2P1, refer to TM 9-2320-302-20-2. For the M915A4P1, refer to TM 9-2320-303-24-1. For the M915A2P1, M916A1P1, M916A2P1, and M917A1P1, refer to TM 9-2320-363-20-2.
11. Install interior light unit. For the M915A3P1, M916A3P1, and M917A2P1, refer to TM 9-2320-302-20-2. For the M915A4P1, refer to TM 9-2320-303-24-1. For the M915A2P1, M916A1P1, M916A2P1, and M917A1P1, refer to TM 9-2320-363-20-2.

**END OF WORK PACKAGE**

---

**A-PILLAR ARMOR REPLACEMENT**

**0022 00**

---

**THIS WORK PACKAGE COVERS**

Removal, Cleaning and Inspection, Installation

---

**INITIAL SETUP**

**Maintenance Level**

Unit

**Tools and Special Tools**

Tool Kit, General Mechanic's (Item 8, WP 0033 00)

**Materials/Parts**

Rag, Wiping (Item 6, WP 0034 00)

**References**

WP 0011 00

**Personnel Required**

Two

**Equipment Conditions**

**(M915A3P1, M916A3P1, and M917A2P1)**

Vehicle parked on level ground (TM 9-2320-302-10)

Parking/Emergency Brake applied (TM 9-2320-302-10)

Engine off (TM 9-2320-302-10)

Battery Disconnect Switch in OFF position (TM 9-2320-302-10)

Door Assembly removed (WP 0012 00)

Front Armor removed (WP 0029 00)

**Equipment Conditions - Continued**

**(M915A4P1)**

Vehicle parked on level ground (TM 9-2320-303-10)

Parking/Emergency Brake applied (TM 9-2320-303-10)

Engine off (TM 9-2320-303-10)

Battery Disconnect Switch in OFF position (TM 9-2320-303-10)

Door Assembly removed (WP 0012 00)

Front Armor removed (WP 0029 00)

**(M915A2P1, M916A1P1, M916A2P1, and M917A1P1)**

Vehicle parked on level ground (TM 9-2320-363-10)

Parking/Emergency Brake applied (TM 9-2320-363-10)

Engine off (TM 9-2320-363-10)

If equipped, Battery Disconnect Switch in OFF position (TM 9-2320-363-10), otherwise, disconnect battery cables (TM 9-2320-363-20-2)

Door Assembly removed (WP 0012 00)

Front Armor removed (WP 0029 00)

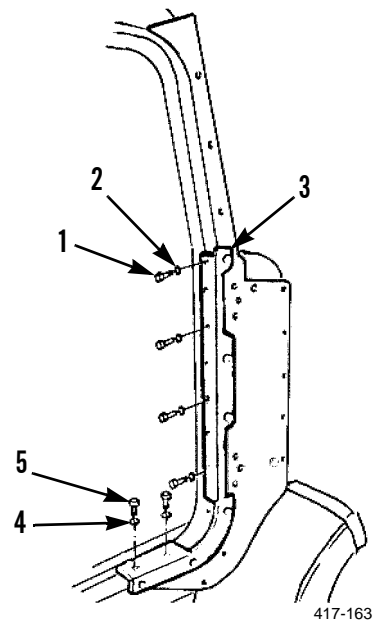
---

**A-PILLAR ARMOR REPLACEMENT - CONTINUED**

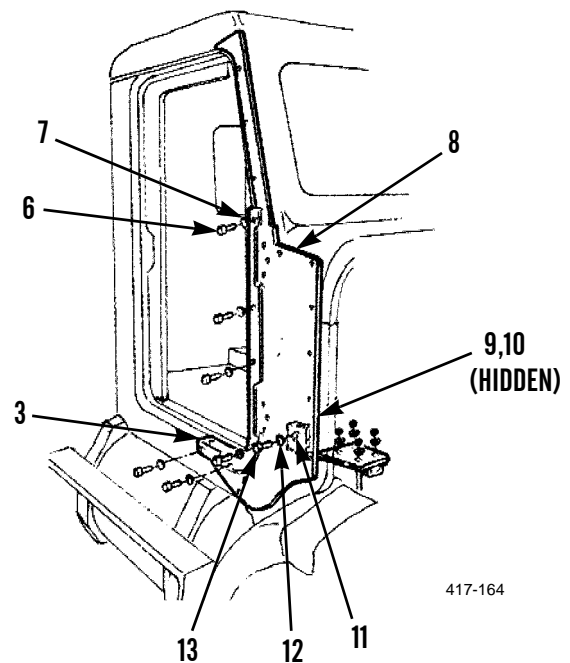
0022 00

**REMOVAL**

1. Remove nine bolts (1) and washers (2) from A-pillar overlap (3).
2. Remove two bolts (5) and washers (4) from bottom of A-pillar overlap (3).



3. Remove nut (9), washer (10), bolt (13), bushing (11), and washer (12) from A-pillar armor (8).



**REMOVAL - CONTINUED****WARNING**

Use extreme caution when handling heavy parts. Provide adequate support and use assistance during procedure. Failure to follow this warning may cause injury to personnel.

**NOTE**

A-pillar armor weighs 93 lb (42 kg) estimated.

4. With assistance, remove six bolts (6), washers (7), A-pillar overlap (3), and A-pillar armor (8) from vehicle.

**CLEANING AND INSPECTION**

Clean and inspect all parts IAW *General Maintenance Instructions* (WP 0011 00).

**INSTALLATION****WARNING**

Use extreme caution when handling heavy parts. Provide adequate support and use assistance during procedure. Failure to follow this warning may cause injury to personnel.

**NOTE**

A-pillar armor weighs 93 lb (42 kg) estimated.

1. With assistance, install A-pillar armor (8), A-pillar overlap (3), six washers (7), and bolts (6) on vehicle.
2. Install washer (12), bushing (11), bolt (13), washer (10), and nut (9) on A-pillar armor (8).
3. Install two washers (4) and bolts (5) on bottom of A-pillar overlap (3).
4. Install nine washers (2) and bolts (1) on A-pillar overlap (3).
5. Install door assembly (WP 0012 00).
6. Install front armor (WP 0029 00).

**END OF WORK PACKAGE**



**REAR ARMOR REPLACEMENT****0023 00****THIS WORK PACKAGE COVERS**

Removal, Cleaning and Inspection, Installation

**INITIAL SETUP****Maintenance Level**

Unit

**Tools and Special Tools**

Tool Kit, General Mechanic's (Item 8, WP 0033 00)

**Materials/Parts**

Rag, Wiping (Item 6, WP 0034 00)

**References**

WP 0011 00

**Personnel Required**

Two

**Equipment Conditions****(M915A3P1, M916A3P1, and M917A2P1)**

Vehicle parked on level ground (TM 9-2320-302-10)

Parking/Emergency Brake applied (TM 9-2320-302-10)

Engine off (TM 9-2320-302-10)

Battery Disconnect Switch in OFF position (TM 9-2320-302-10)

Right and Left Seats removed (TM 9-2320-302-20-2)

Transmission Shift Tower removed (TM 9-2320-302-20-2)

Fire Extinguisher Bracket removed (TM 9-2320-302-20-2)

If equipped, Arctic Heater Box removed (TM 9-2320-302-20-2)

Escape Hatch removed (WP 0027 00)

**(M915A4P1)**

Vehicle parked on level ground (TM 9-2320-303-10)

Parking/Emergency Brake applied (TM 9-2320-303-10)

**Equipment Conditions - Continued**

Engine off (TM 9-2320-303-10)

Battery Disconnect Switch in OFF position (TM 9-2320-303-10)

Right and Left Seats removed (TM 9-2320-303-24-1)

Transmission Shift Tower removed (TM 9-2320-303-24-1)

Fire Extinguisher Bracket removed (TM 9-2320-303-24-1)

If equipped, Arctic Heater Box removed (TM 9-2320-303-24-1)

Escape Hatch removed (WP 0027 00)

**(M915A2P1, M916A1P1, M916A2P1, and M917A1P1)**

Vehicle parked on level ground (TM 9-2320-363-10)

Parking/Emergency Brake applied (TM 9-2320-363-10)

Engine off (TM 9-2320-363-10)

If equipped, Battery Disconnect Switch in OFF position (TM 9-2320-363-10) otherwise, disconnect battery cables (TM 9-2320-363-20-2)

Right and Left Seats removed (TM 9-2320-363-20-2)

Transmission Shift Tower removed (TM 9-2320-363-20-2)

Fire Extinguisher Bracket removed (TM 9-2320-363-20-2)

If equipped, Arctic Heater Box removed (TM 9-2320-363-20-2)

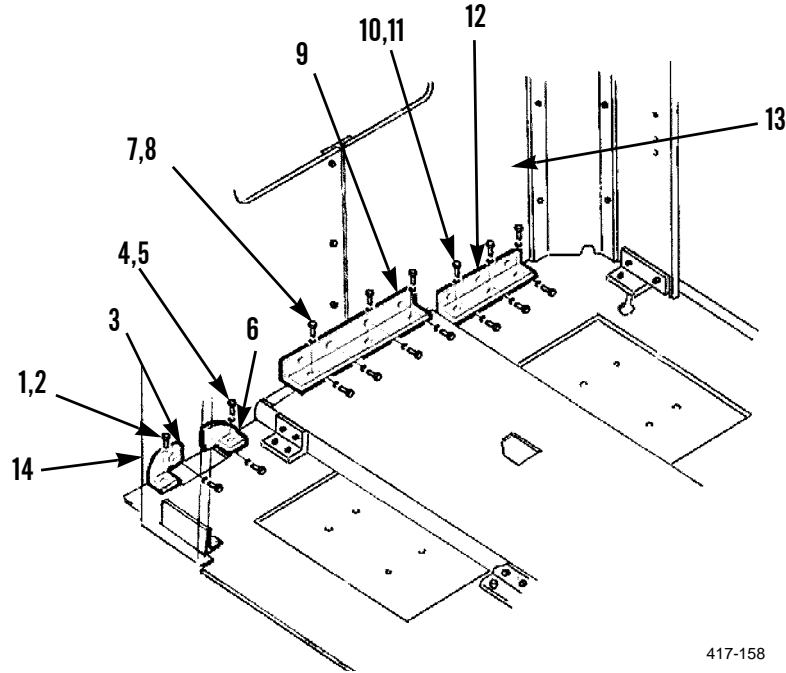
Escape Hatch removed (WP 0027 00)

REAR ARMOR REPLACEMENT - CONTINUED

0023 00

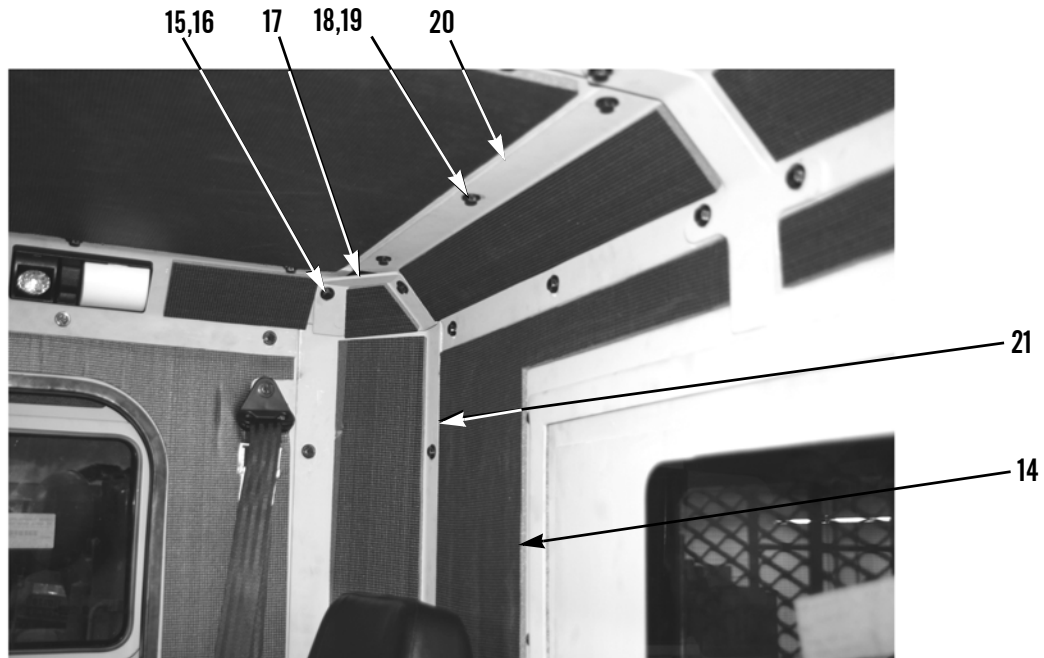
REMOVAL

1. Remove two bolts (1), washers (2), and bracket (3) from right rear wall armor (14).
2. Remove two bolts (4), washers (5), and bracket (6) from right rear wall armor (14).
3. Remove seven bolts (7), washers (8), and bracket (9) from right rear wall armor (14) and left rear wall armor (13).
4. Remove six bolts (10), washers (11), and bracket (12) from left rear wall armor (13).



417-158

5. Remove four bolts (15), washers (16), and right and left rear corner brackets (17) from right and left rear B-pillar (21).
6. Remove six bolts (18), washers (19), and right backside roof bar (20) from right rear wall armor (14).



417-283



**REMOVAL - CONTINUED**

7. Remove eight bolts (22), washers (23), and right rear B-pillar (21) from right rear wall armor (14).

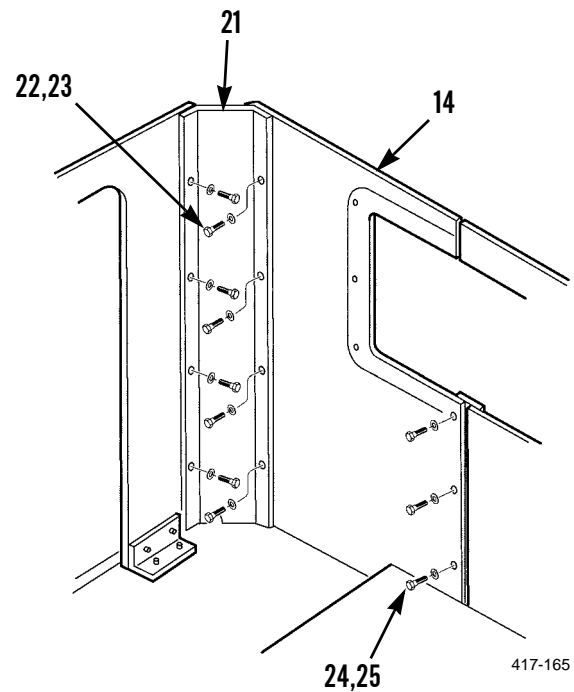
**WARNING**

Use extreme caution when handling heavy parts. Provide adequate support and use assistance during procedure. Failure to follow this warning may cause injury or death to personnel.

**NOTE**

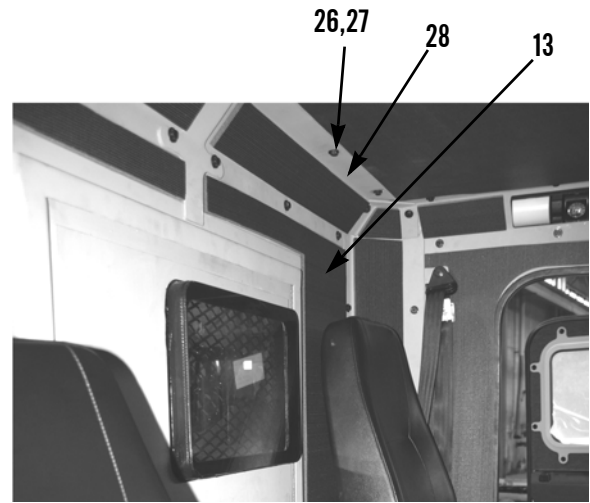
Right rear wall armor weighs 123 lb (56 kg) estimated.

8. With assistance, remove three bolts (24), washers (25), and right rear wall armor (14) from vehicle.



**REMOVAL - CONTINUED**

9. Remove six bolts (26), washers (27), and left backside roof bar (28) from left rear wall armor (13).



417-284



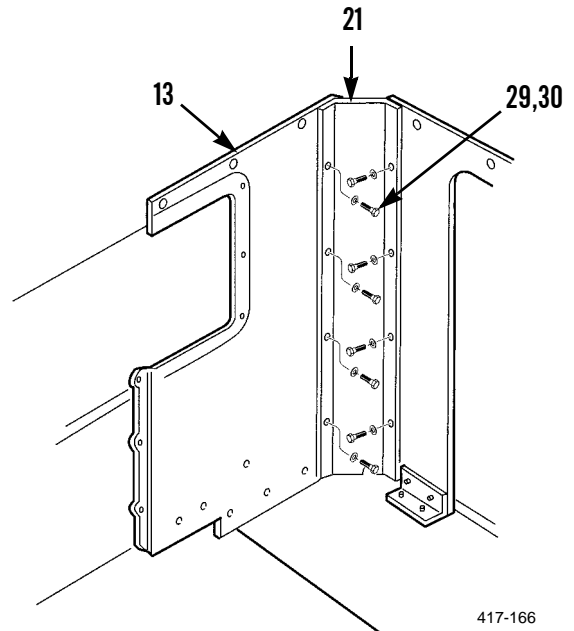
**WARNING**

Use extreme caution when handling heavy parts. Provide adequate support and use assistance during procedure. Failure to follow this warning may cause injury or death to personnel.

**NOTE**

Left rear wall armor weighs 123 lb (56 kg) estimated.

10. With assistance, remove eight bolts (29), washers (30), left rear B-pillar (21), and left rear wall armor (13) from vehicle.



417-166

**CLEANING AND INSPECTION**

Clean and inspect all parts IAW *General Maintenance Instructions* (WP 0011 00).

**INSTALLATION****WARNING**

Use extreme caution when handling heavy parts. Provide adequate support and use assistance during procedure. Failure to follow this warning may cause injury or death to personnel.

**NOTE**

Left rear wall armor weighs 123 lb (56 kg) estimated.

1. With assistance, install left rear wall armor (13), left rear B-pillar (21), eight washers (30), and bolts (29) on vehicle.
2. Install left backside roof bar (28), six washers (27), and bolts (26) on left rear wall armor (13).

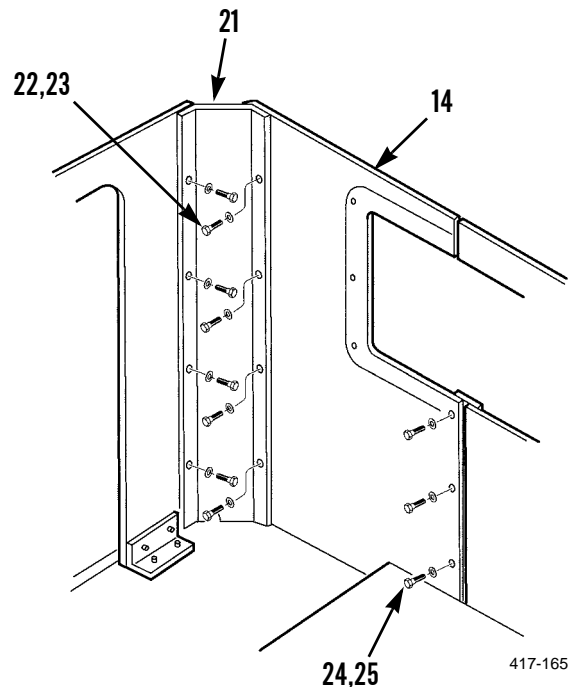
**WARNING**

Use extreme caution when handling heavy parts. Provide adequate support and use assistance during procedure. Failure to follow this warning may cause injury or death to personnel.

**NOTE**

Right rear wall armor weighs 123 lb (56 kg) estimated.

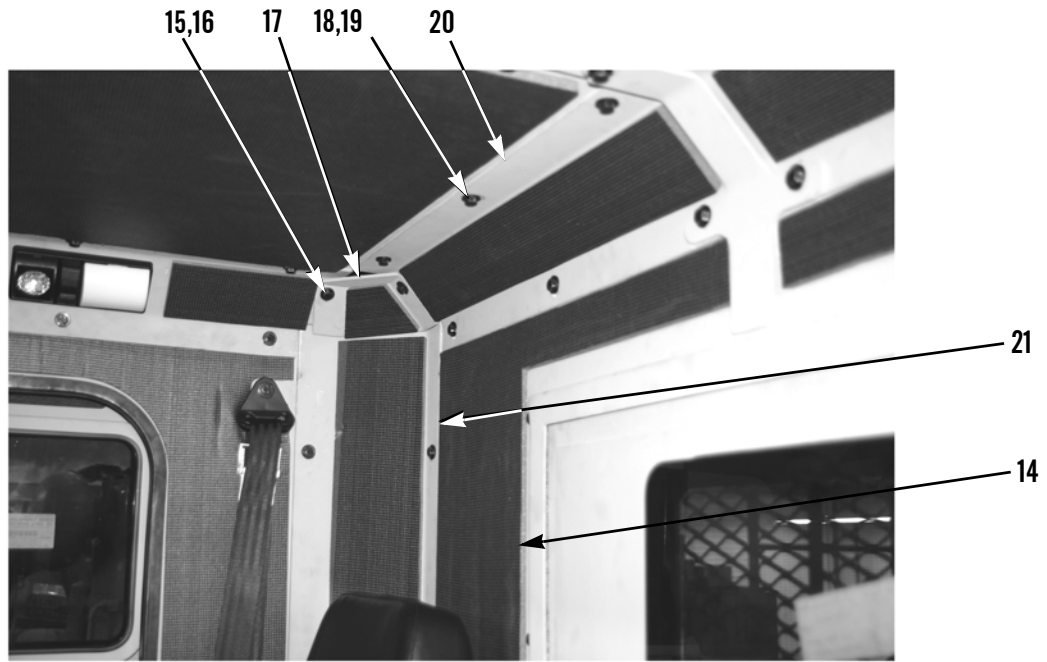
3. With assistance, install right rear wall armor (14), three washers (25), and bolts (24) on vehicle.
4. Install right rear B-pillar (21), eight washers (23), and bolts (22) on right rear wall armor (14).



417-165

**REAR ARMOR REPLACEMENT - CONTINUED****0023 00****INSTALLATION - CONTINUED**

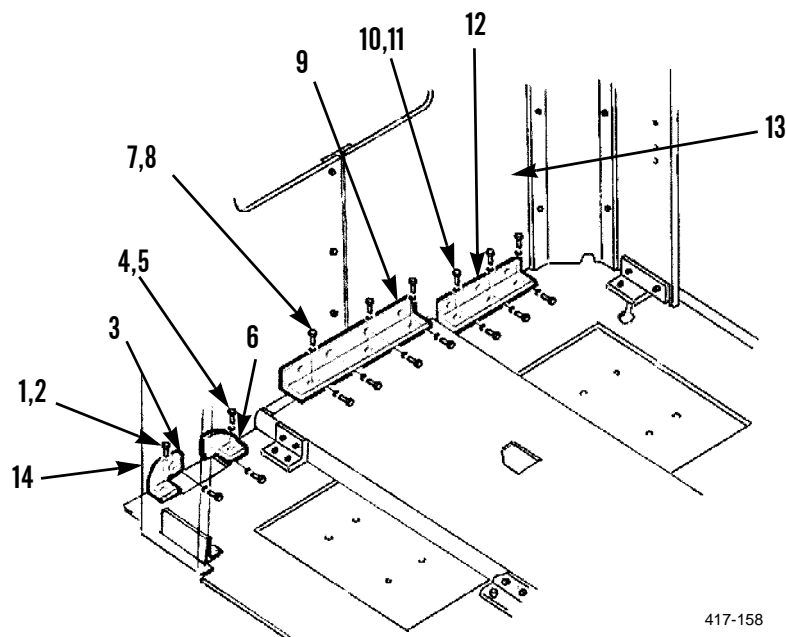
5. Install right backside roof bar (20), six washers (19), and bolts (18) on right rear wall armor (14).
6. Install right and left rear corner brackets (17), four washers (16), and bolts (15) on right and left rear B-pillar (21).



417-283

**REAR ARMOR REPLACEMENT - CONTINUED****0023 00****INSTALLATION - CONTINUED**

7. Install bracket (12), six washers (11), and bolts (10) on left rear wall armor (13).
8. Install bracket (9), seven washers (8), and bolts (7) on right rear wall armor (14) and left rear wall armor (13).
9. Install bracket (6), two washers (5), and bolts (4) on right rear wall armor (14).
10. Install bracket (3), two washers (2), and bolts (1) on right rear wall armor (14).



417-158

11. Install escape hatch (WP 0027 00).
12. If equipped, install arctic heater box. For the M915A3P1, M916A3P1, and M917A2P1, refer to TM 9-2320-302-20-2. For the M915A4P1, refer to TM 9-2320-303-24-1. For the M915A2P1, M916A1P1, M916A2P1, and M917A1P1, refer to TM 9-2320-363-20-2.
13. Install fire extinguisher bracket. For the M915A3P1, M916A3P1, and M917A2P1, refer to TM 9-2320-302-20-2. For the M915A4P1, refer to TM 9-2320-303-24-1. For the M915A2P1, M916A1P1, M916A2P1, and M917A1P1, refer to TM 9-2320-363-20-2.
14. Install transmission shift tower. For the M915A3P1, M916A3P1, and M917A2P1, refer to TM 9-2320-302-20-2. For the M915A4P1, refer to TM 9-2320-303-24-1. For the M915A2P1, M916A1P1, M916A2P1, and M917A1P1, refer to TM 9-2320-363-20-2.
15. Install right and left seats. For the M915A3P1, M916A3P1, and M917A2P1, refer to TM 9-2320-302-20-2. For the M915A4P1, refer to TM 9-2320-303-24-1. For the M915A2P1, M916A1P1, M916A2P1, and M917A1P1, refer to TM 9-2320-363-20-2.

**END OF WORK PACKAGE**



---

**ROOF ARMOR REPLACEMENT**

**0024 00**

---

**THIS WORK PACKAGE COVERS**

Removal, Cleaning and Inspection, Installation

---

**INITIAL SETUP**

**Maintenance Level**

Unit

**Tools and Special Tools**

Tool Kit, General Mechanic's (Item 8, WP 0033 00)

**Materials/Parts**

Rag, Wiping (Item 6, WP 0034 00)

**References**

WP 0011 00

**Personnel Required**

Two

**Equipment Conditions**

**(M915A3P1, M916A3P1, and M917A2P1)**

Vehicle parked on level ground (TM 9-2320-302-10)

Parking/Emergency Brake applied (TM 9-2320-302-10)

Engine off (TM 9-2320-302-10)

Battery Disconnect Switch in OFF position (TM 9-2320-302-10)

Interior Light Units removed (TM 9-2320-302-20-2)

If necessary, Foam Insulation removed (WP 0030 00)

**Equipment Conditions - Continued**

**(M915A4P1)**

Vehicle parked on level ground (TM 9-2320-303-10)

Parking/Emergency Brake applied (TM 9-2320-303-10)

Engine off (TM 9-2320-303-10)

Battery Disconnect Switch in OFF position (TM 9-2320-303-10)

Interior Light Units removed (TM 9-2320-303-24-1)

If necessary, Foam Insulation removed (WP 0030 00)

**(M915A2P1, M916A1P1, M916A2P1, and M917A1P1)**

Vehicle parked on level ground (TM 9-2320-363-10)

Parking/Emergency Brake applied (TM 9-2320-363-10)

Engine off (TM 9-2320-363-10)

If equipped, Battery Disconnect Switch in OFF position (TM 9-2320-363-10) otherwise, disconnect battery cables (TM 9-2320-363-20-2)

Interior Light Units removed (TM 9-2320-363-20-2)

If necessary, Foam Insulation removed (WP 0030 00)

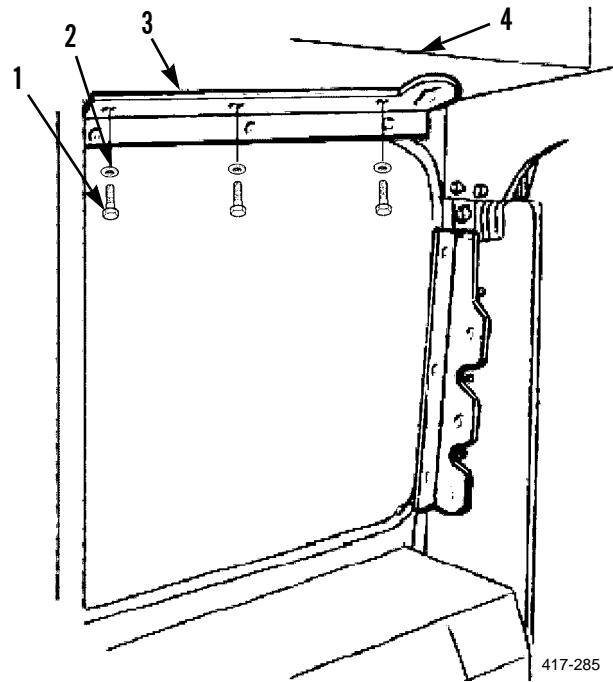
---

**ROOF ARMOR REPLACEMENT - CONTINUED**

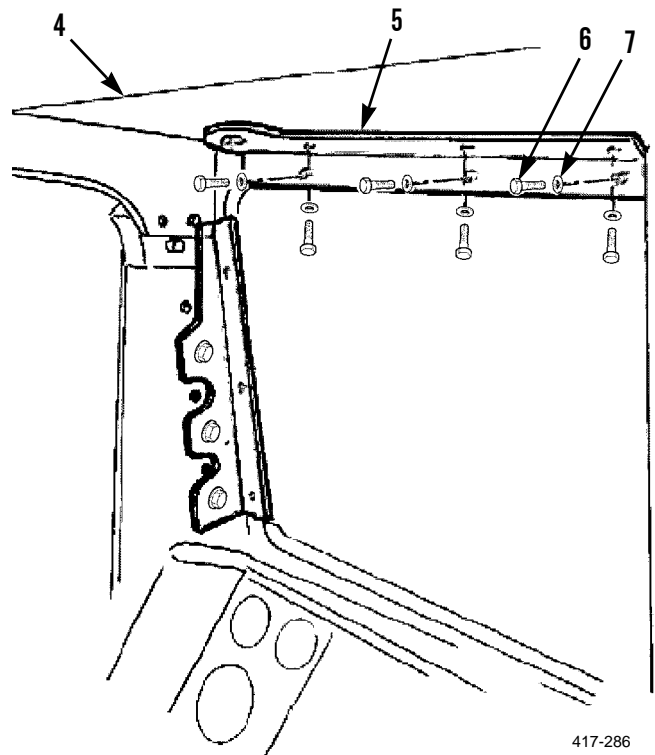
0024 00

**REMOVAL**

1. Remove six bolts (1), washers (2), and right front window bracket (3) from front roof panel (4).



2. Remove six bolts (6), washers (7), and left front window bracket (5) from front roof panel (4).





**REMOVAL - CONTINUED**

3. Remove four bolts (11), washers (12), and bracket (10) from front roof panel (4).



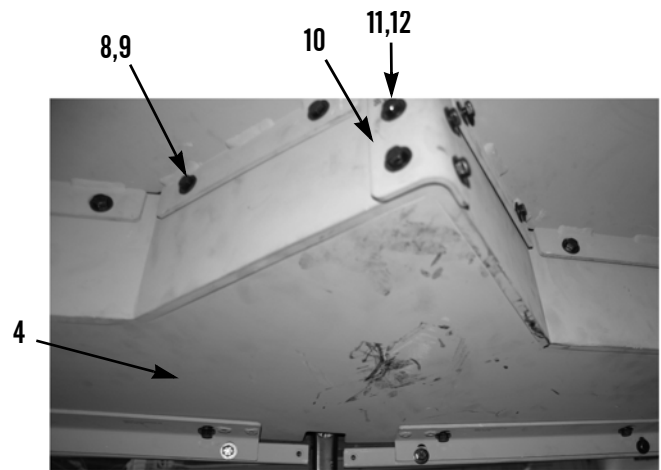
**WARNING**

Use extreme caution when handling heavy parts. Provide adequate support and use assistance during procedure. Failure to follow this warning may cause injury or death to personnel.

**NOTE**

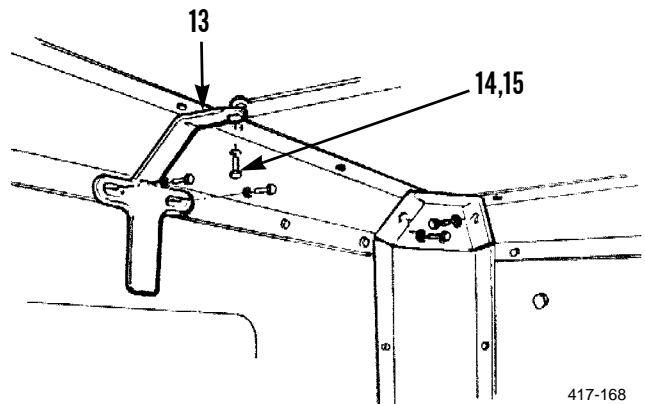
Front roof panel armor weighs 56 lb (26 kg) estimated.

4. With assistance, remove 12 bolts (8), washers (9), and front roof panel (4) from vehicle.



417-287

5. Remove three bolts (14), washers (15), and rear roof overlap (13) from above escape hatch.



417-168

**ROOF ARMOR REPLACEMENT - CONTINUED****0024 00****REMOVAL - CONTINUED**

- Remove two bolts (26), washers (27), and left rear corner bracket (25) from left rear roof panel (21).

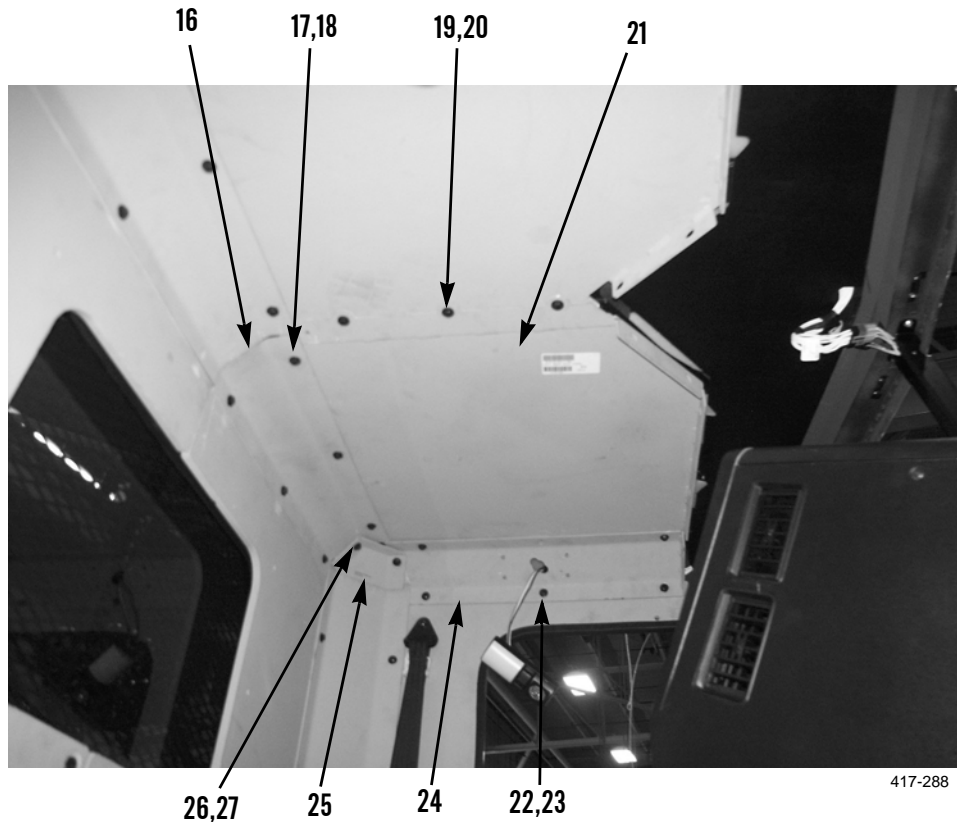
**WARNING**

Use extreme caution when handling heavy parts. Provide adequate support and use assistance during procedure. Failure to follow this warning may cause injury or death to personnel.

**NOTE**

Left roof panel armor weighs 56 lb (26 kg) estimated.

- With assistance, remove six bolts (22), washers (23), and left roof overlap (24) from left roof panel (21).
- With assistance, remove five bolts (17), washers (18), and left backside roof bar (16) from left roof panel (21).
- With assistance, remove three bolts (19), washers (20), and left roof panel (21) from vehicle.



**REMOVAL - CONTINUED**

10. Remove two bolts (33), washers (34), and right rear corner bracket (32) from right rear roof panel (28).

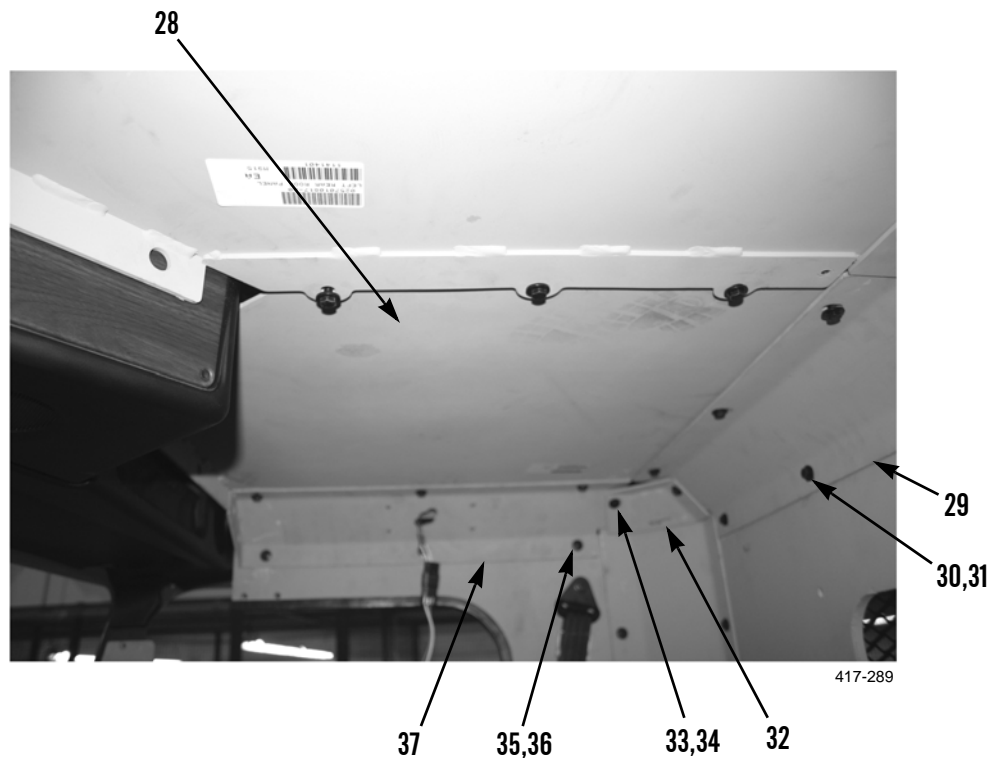
**WARNING**

Use extreme caution when handling heavy parts. Provide adequate support and use assistance during procedure. Failure to follow this warning may cause injury or death to personnel.

**NOTE**

Right roof panel armor weighs 56 lb (26 kg) estimated.

11. With assistance, remove six bolts (35), washers (36), and right roof overlap (37) from right roof panel (28).  
 12. With assistance, remove five bolts (30), washers (31), right backside roof bar (29), and right roof panel (28) from vehicle.

**CLEANING AND INSPECTION**

Clean and inspect all parts IAW *General Maintenance Instructions* (WP 0011 00).

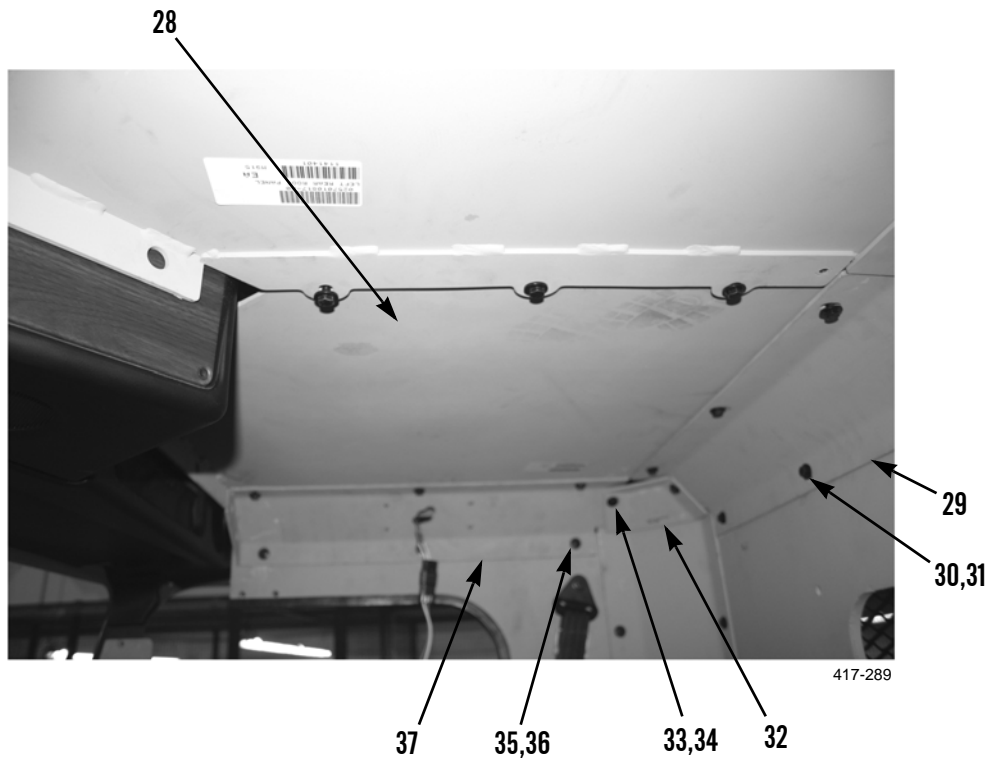
**INSTALLATION****WARNING**

Use extreme caution when handling heavy parts. Provide adequate support and use assistance during procedure. Failure to follow this warning may cause injury or death to personnel.

**NOTE**

Right roof panel armor weighs 56 lb (26 kg) estimated.

1. With assistance, install right roof panel (28), right backside roof bar (29), five washers (31), and bolts (30) on vehicle.
2. With assistance, install right roof overlap (37), six washers (36), and bolts (35) on right roof panel (28).
3. Install right rear corner bracket (32), two washers (34), and bolts (33) on right roof panel (28).



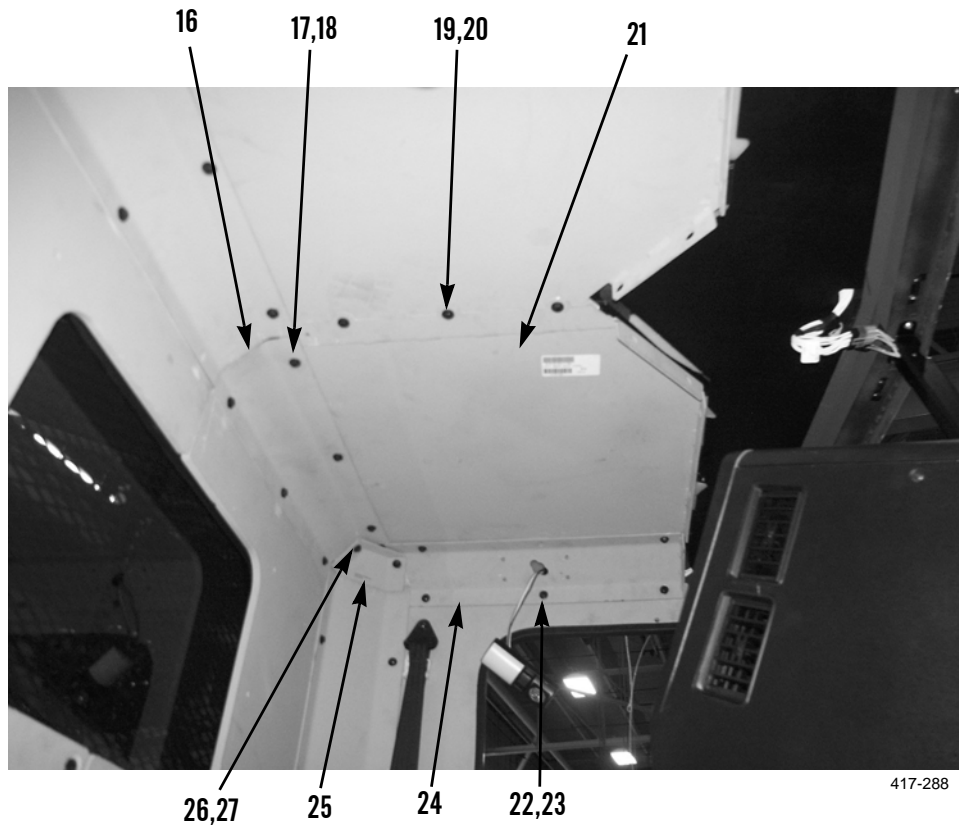
**INSTALLATION - CONTINUED****WARNING**

Use extreme caution when handling heavy parts. Provide adequate support and use assistance during procedure. Failure to follow this warning may cause injury or death to personnel.

**NOTE**

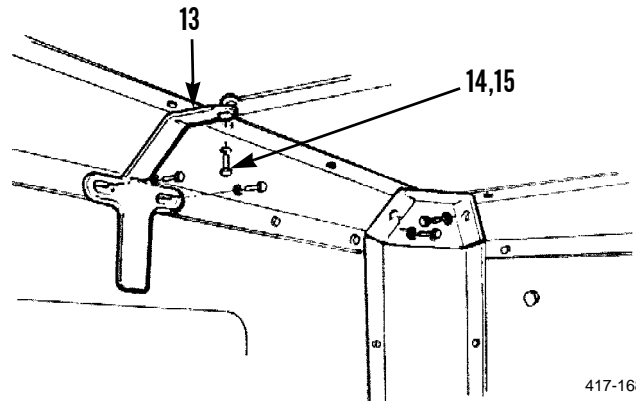
Left roof panel armor weighs 56 lb (26 kg) estimated.

4. With assistance, install left roof panel (21), three washers (20), and bolts (19) on vehicle.
5. With assistance, install left backside roof bar (16), five washers (18), and bolts (17) on left roof panel (21).
6. With assistance, install left roof overlap (24), six washers (23), and bolts (22) on left roof panel (21).
7. Install left corner bracket (25), two washers (27), and bolts (26) on left roof panel (21).



**INSTALLATION - CONTINUED**

8. Install rear roof overlap (13), three washers (15), and bolts (14) above escape hatch.



417-168



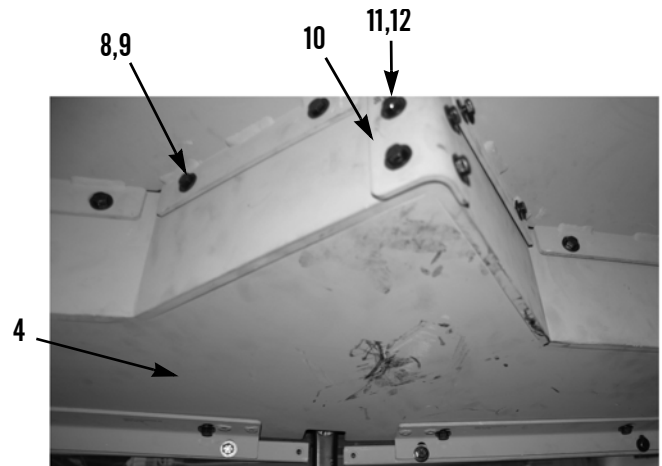
**WARNING**

Use extreme caution when handling heavy parts. Provide adequate support and use assistance during procedure. Failure to follow this warning may cause injury or death to personnel.

**NOTE**

Front roof panel armor weighs 56 lb (26 kg) estimated.

9. With assistance, install front roof panel (4), 12 washers (9), and bolts (8) on vehicle.
10. Install bracket (10), four washers (12), and bolts (11) on front roof panel (4).



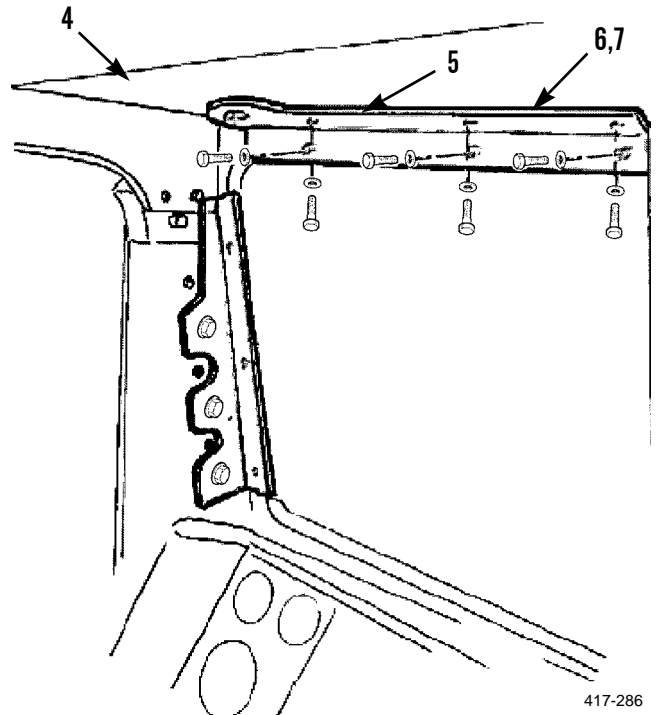
417-287

## ROOF ARMOR REPLACEMENT - CONTINUED

0024 00

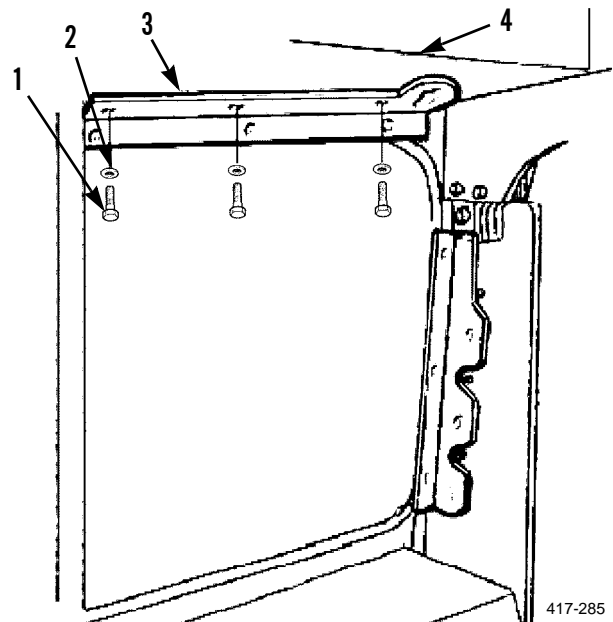
**INSTALLATION - CONTINUED**

11. Install left front window bracket (5), six washers (7), and bolts (6) on front roof panel (4).



417-286

12. Install right front window bracket (3), six washers (2), and bolts (1) on front roof panel (4).



417-285

13. Install interior light units. For the M915A3P1, M916A3P1, and M917A2P1, refer to TM 9-2320-302-20-2. For the M915A4P1, refer to TM 9-2320-303-24-1. For the M915A2P1, M916A1P1, M916A2P1, and M917A1P1, refer to TM 9-2320-363-20-2.
14. If removed, install foam insulation (WP 0030 00).

**END OF WORK PACKAGE**





---

**WINDSHIELD BALLISTIC GLASS REPLACEMENT**

**0025 00**

---

**THIS WORK PACKAGE COVERS**

Removal, Cleaning and Inspection, Installation

---

**INITIAL SETUP**

**Maintenance Level**

Unit

**Tools and Special Tools**

Tool Kit, General Mechanic's (Item 8, WP 0033 00)

**Materials/Parts**

Rag, Wiping (Item 6, WP 0034 00)

Sealing Compound, Urethane (Item 7, WP 0034 00)

Sika Primer (Item 8, WP 0034 00)

**References**

WP 0011 00

**Personnel Required**

Two

**Equipment Conditions**

**(M915A3P1, M916A3P1, and M917A2P1)**

Vehicle parked on level ground (TM 9-2320-302-10)

Parking/Emergency Brake applied (TM 9-2320-302-10)

Engine off (TM 9-2320-302-10)

Battery Disconnect Switch in OFF position (TM 9-2320-302-10)

**Equipment Conditions - Continued**

**(M915A4P1)**

Vehicle parked on level ground (TM 9-2320-303-10)

Parking/Emergency Brake applied (TM 9-2320-303-10)

Engine off (TM 9-2320-303-10)

Battery Disconnect Switch in OFF position (TM 9-2320-303-10)

**(M915A2P1, M916A1P1, M916A2P1, and M917A1P1)**

Vehicle parked on level ground (TM 9-2320-363-10)

Parking/Emergency Brake applied (TM 9-2320-363-10)

Engine off (TM 9-2320-363-10)

If equipped, Battery Disconnect Switch in OFF position (TM 9-2320-363-10) otherwise, disconnect battery cables (TM 9-2320-363-20-2)

---

**CAUTION**

Never use impact tools when removing or installing ballistic glass. Failure to follow this caution may damage ballistic glass.

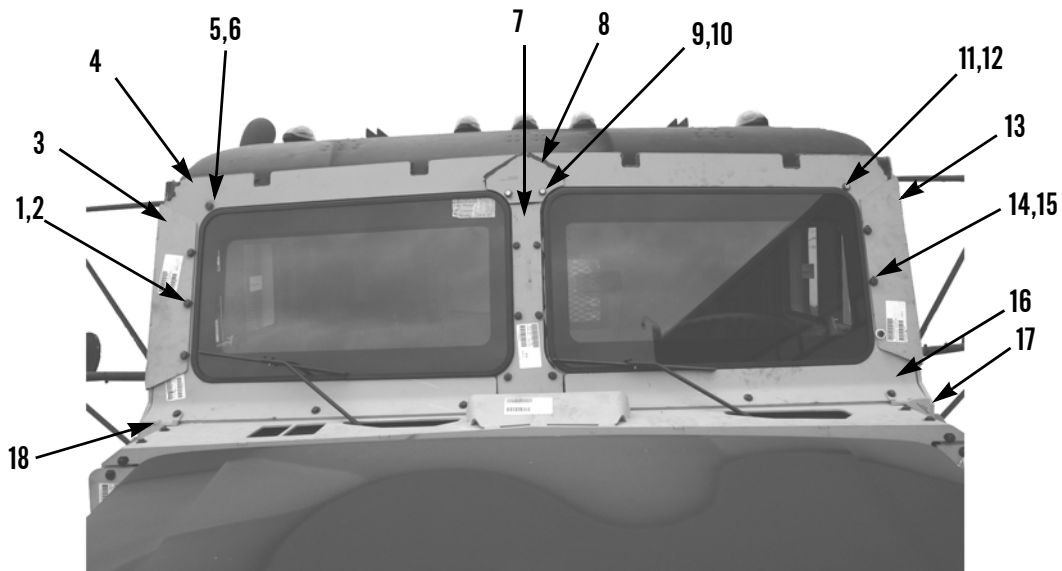
**REMOVAL**

1. Remove six bolts (1), washers (2), and right A-pillar overlap (3) from right windscreen surround overlap (4).
2. Remove six bolts (14), washers (15), and left A-pillar overlap (13) from left windscreen surround overlap (16).
3. Remove eight bolts (9), washers (10), bracket (8), and center windscreen overlap (7) from vehicle.

**WARNING**

Use extreme caution when handling heavy parts. Provide adequate support and use assistance during procedure. Failure to follow this warning may cause injury or death to personnel.

4. With assistance, remove four bolts (11), washers (12), left corner welding (17), and left windscreen surround overlap (19).
5. With assistance, remove four bolts (5), washers (6), right corner welding (18), and right windscreen surround overlap (4).

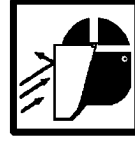


417-502

## REMOVAL - CONTINUED



WARNING

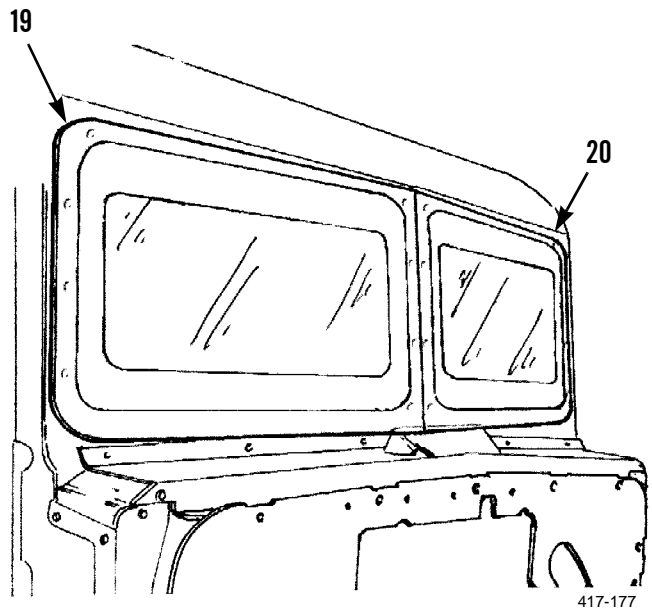


- Use extreme caution when handling heavy parts. Provide adequate support and use assistance during procedure. Failure to follow this warning may cause injury or death to personnel.
- Use caution when handling window glass. Glass can break unexpectedly during removal/installation procedure. Wear face shield, apron, and gloves. Failure to follow this warning may cause injury to personnel.

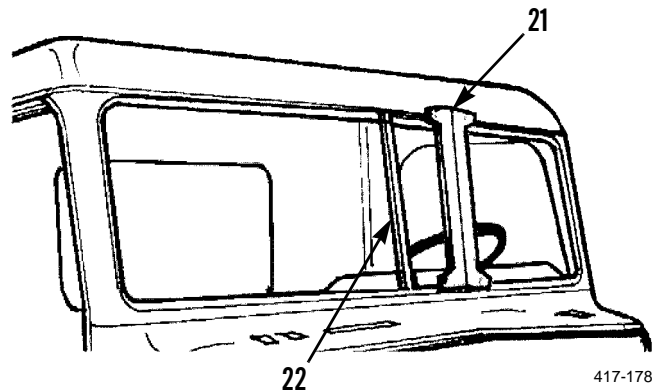
## NOTE

Left and right ballistic glass weighs 83 lb (37.5 kg) each estimated.

6. With assistance, remove left ballistic glass (20) and right ballistic glass (19) from vehicle.



7. Remove front window sealer plate (21) from center windshield support (22).

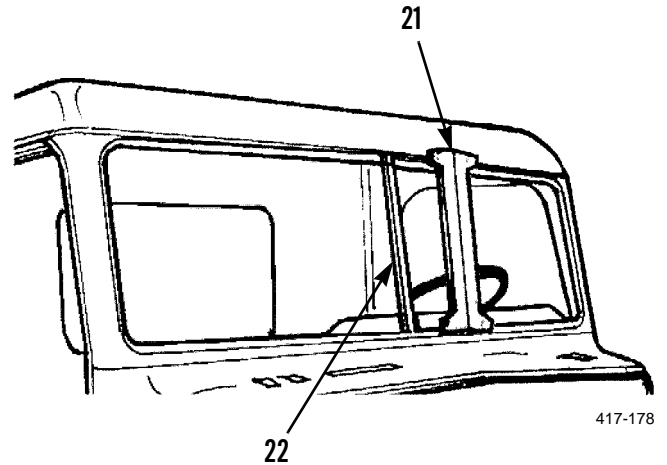


**CLEANING AND INSPECTION**

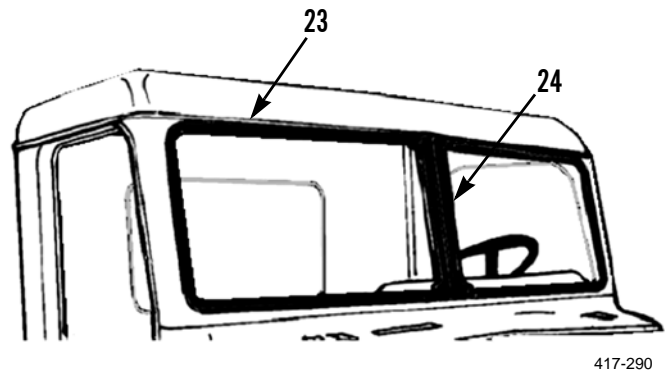
Clean and inspect all parts IAW *General Maintenance Instructions* (WP 0011 00).

**INSTALLATION**

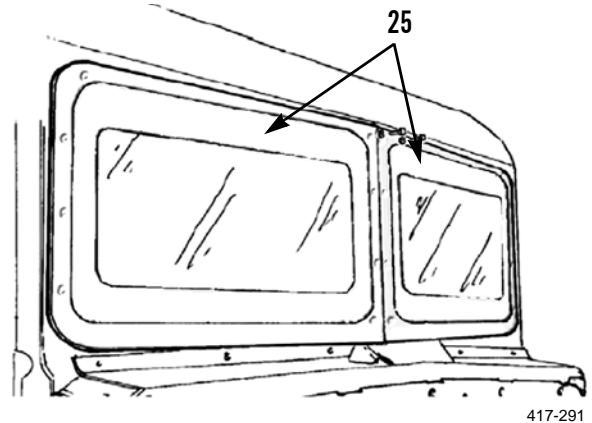
1. Install front window sealer plate (21) on center windshield support (22).



2. Apply primer on areas indicated by dark lines around windshield (23). Allow primer to dry.
3. Apply generous bead of sealant on primed area around windshield (23). Encircle all holes and across ends of center windshield support (24) with sealant.



4. Apply primer on mating areas of windshield frames (25).



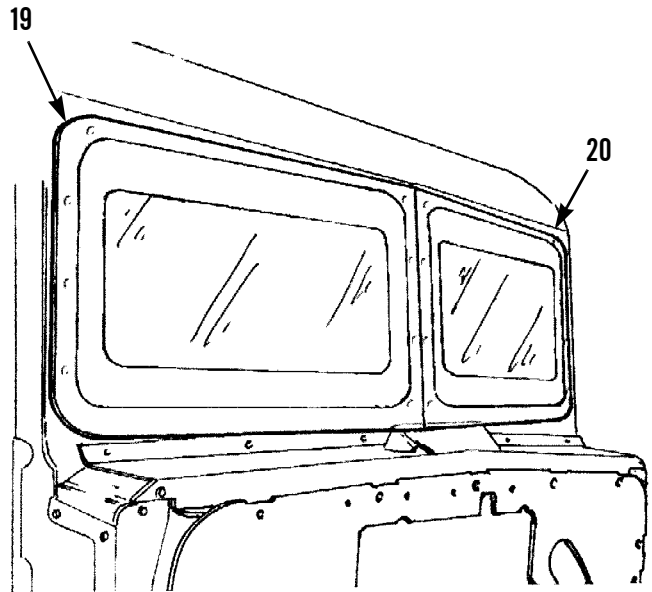
**INSTALLATION - CONTINUED****WARNING**

- Use extreme caution when handling heavy parts. Provide adequate support and use assistance during procedure. Failure to follow this warning may cause injury or death to personnel.
- Use caution when handling window glass. Glass can break unexpectedly during removal/installation procedure. Wear face shield, apron, and gloves. Failure to follow this warning may cause injury to personnel.
- For proper threat protection, ballistic glass must be correctly installed onto ballistic glass frame. During installation, ensure that decal "INSTALL THIS SURFACE TOWARDS THREAT" is located on outside of cab. Improperly installed windshield ballistic glass will not protect occupants. Failure to follow this warning may cause injury or death to personnel.

**NOTE**

Left and right ballistic glass weighs 83 lb (37.5 kg) each estimated.

5. With assistance, install left ballistic glass (20) and right ballistic glass (19) on vehicle.

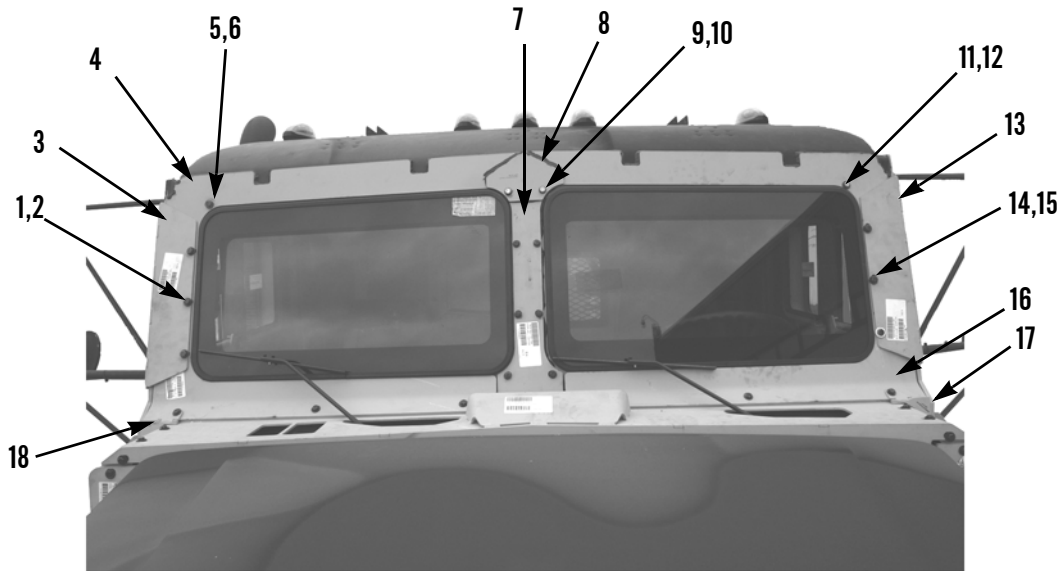


417-177

**INSTALLATION - CONTINUED****WARNING**

Use extreme caution when handling heavy parts. Provide adequate support and use assistance during procedure. Failure to follow this warning may cause injury or death to personnel.

6. With assistance, install right windscreen surround overlap (4), right corner welding (18), four washers (6), and bolts (5) on vehicle.
7. With assistance, install left windscreen surround overlap (16), left corner welding (17), four washers (12), and bolts (11) on vehicle.
8. Install center overlap (7), bracket (8), eight washers (10), and bolts (9) on vehicle.
9. Install left A-pillar overlaps (13), six washers (15), and bolts (14) on left windscreen surround overlap (16).
10. Install right A-pillar overlaps (3), six washers (2), and bolts (1) on right windscreen surround overlap (4).
11. Apply a bead of sealant between top forward edge of cab and back upper surface of windshield.
12. Apply a bead of sealant around right overlap (3) and left overlap (13).



417-502

**END OF WORK PACKAGE**

---

**FIREWALL ARMOR REPLACEMENT**

**0026 00**

---

**THIS WORK PACKAGE COVERS**

Removal, Cleaning and Inspection, Installation

---

**INITIAL SETUP**

**Maintenance Level**

Unit

**Tools and Special Tools**

Tool Kit, General Mechanic's (Item 8, WP 0033 00)

**Materials/Parts**

Rag, Wiping (Item 6, WP 0034 00)

**References**

WP 0011 00

**Equipment Conditions**

**(M915A3P1, M916A3P1, and M917A2P1)**

Vehicle parked on level ground (TM 9-2320-302-10)

Parking/Emergency Brake applied (TM 9-2320-302-10)

Engine off (TM 9-2320-302-10)

Battery Disconnect Switch in OFF position (TM 9-2320-302-10)

**Equipment Conditions - Continued**

**(M915A4P1)**

Vehicle parked on level ground (TM 9-2320-303-10)

Parking/Emergency Brake applied (TM 9-2320-303-10)

Engine off (TM 9-2320-303-10)

Battery Disconnect Switch in OFF position (TM 9-2320-303-10)

**(M915A2P1, M916A1P1, M916A2P1, and M917A1P1)**

Vehicle parked on level ground (TM 9-2320-363-10)

Parking/Emergency Brake applied (TM 9-2320-363-10)

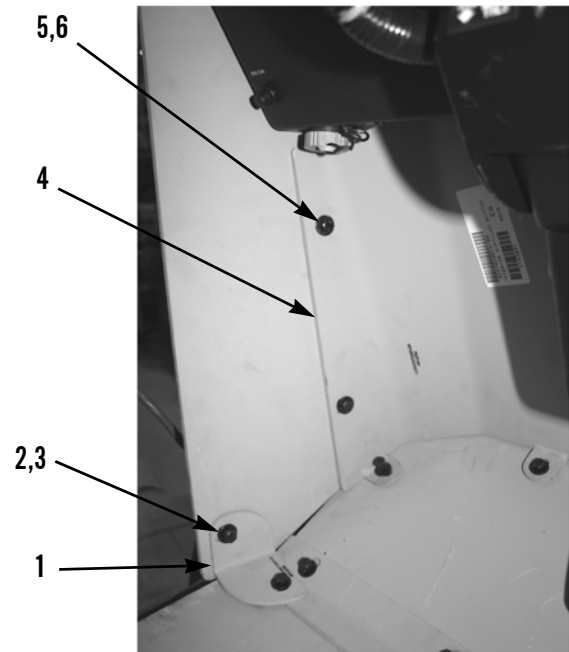
Engine off (TM 9-2320-363-10)

If equipped, Battery Disconnect Switch in OFF position (TM 9-2320-363-10) otherwise, disconnect battery cables (TM 9-2320-363-20-2)

---

**FIREWALL ARMOR REPLACEMENT - CONTINUED****0026 00****REMOVAL**

1. Remove two bolts (2), washers (3), and bracket (1) from bottom of A-pillar (4).
2. Remove four bolts (5), washers (6), and A-pillar (4) from left firewall.

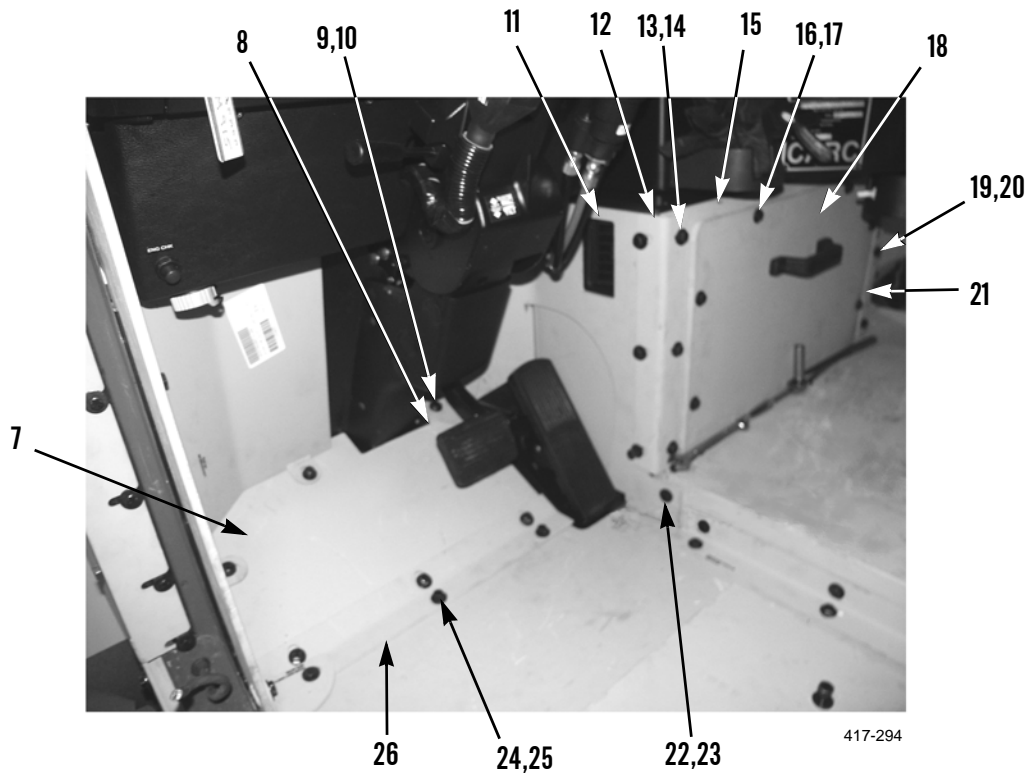


417-293



**FIREWALL ARMOR REPLACEMENT - CONTINUED****0026 00****REMOVAL - CONTINUED**

3. Remove two bolts (9), washers (10), and bracket (8) from top of left side toe board (7).
4. Remove five bolts (24), washers (25), angle bracket (26), and left side toe board (7).
5. Remove six bolts (13), washers (14), and angle bracket (12) from left side firewall (11).
6. Remove bolt (22), washer (23), and left side firewall (11).
7. Remove six bolts (16), washers (17), and firewall service hatch (18) from center firewall frame (15).
8. Remove three bolts (19), washers (20), and center firewall frame (15) from bracket (21).

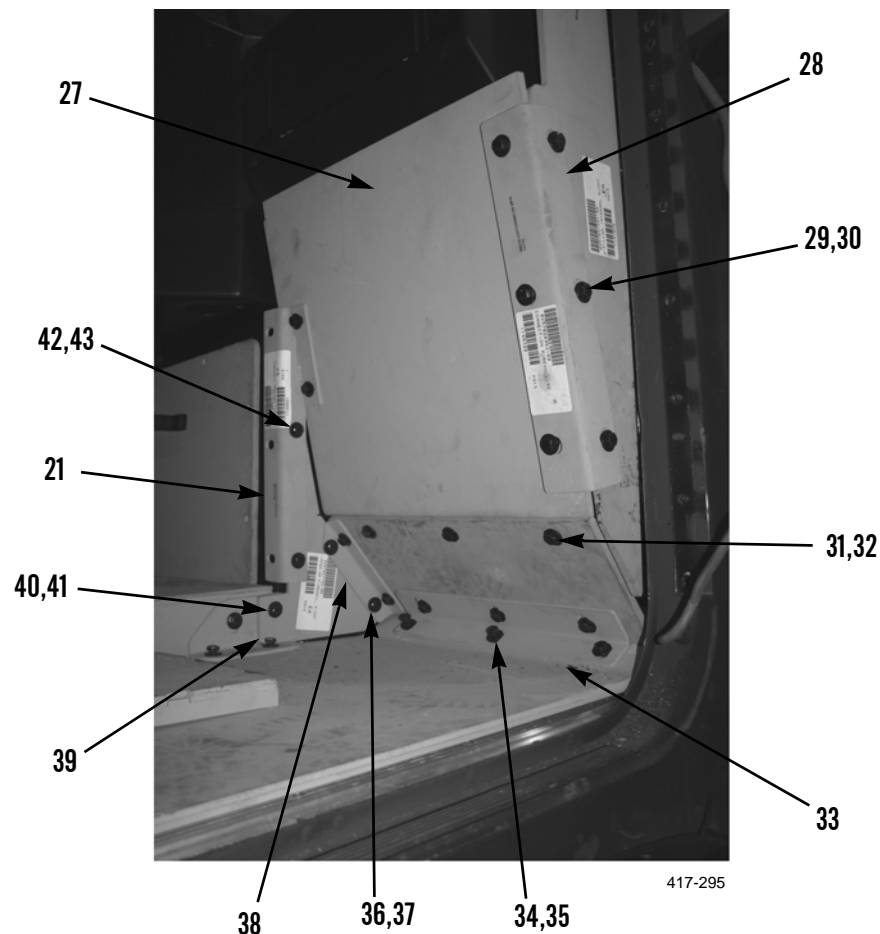


**FIREWALL ARMOR REPLACEMENT - CONTINUED**

0026 00

**REMOVAL - CONTINUED**

9. Remove six bolts (29), washers (30), and angle bracket (28) from right side firewall (27).
10. Remove six bolts (34), washers (35), and angle bracket (33) from right side firewall (27).
11. Remove four bolts (36), washers (37), and angle bracket (38) from right side firewall (27).
12. Remove four bolts (42), washers (43), and bracket (21) from right side firewall (27).
13. Remove bolt (40), washer (41), and bracket (39).
14. Remove three bolts (31), washers (32), and right side firewall (27).

**CLEANING AND INSPECTION**

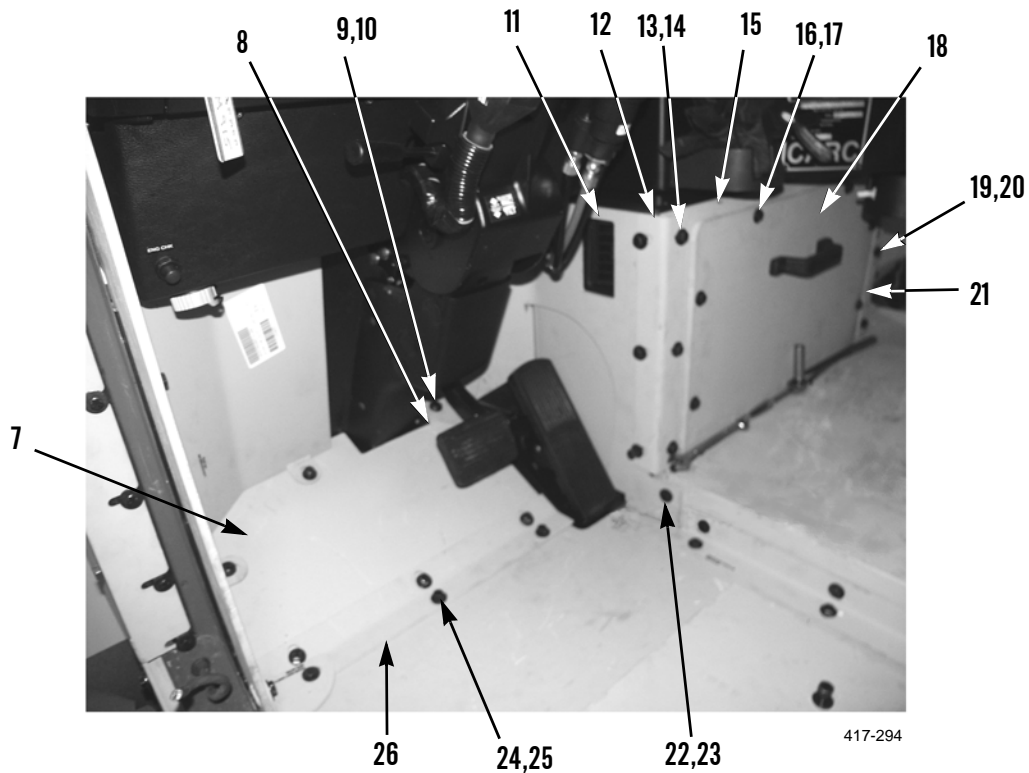
Clean and inspect all parts IAW *General Maintenance Instructions* (WP 0011 00).

**INSTALLATION**

1. Install right side firewall (27), three washers (32), and bolts (31) on right firewall.
2. Install bracket (39), washer (41), and bolt (40).
3. Install bracket (21), four washers (43), and bolts (42) on right side firewall (27).
4. Install angle bracket (38), four washers (37), and bolts (36) on right side firewall (27).
5. Install angle bracket (33), six washers (35), and bolts (34) on right side firewall (27).
6. Install angle bracket (28), six washers (30), and bolts (29) on right side firewall (27).

**FIREWALL ARMOR REPLACEMENT - CONTINUED****0026 00****INSTALLATION - CONTINUED**

7. Install center firewall frame (15), three washers (20), and bolts (19) on bracket (21).
8. Install firewall service hatch (18), six washers (17), and bolts (16) on center firewall frame (15).
9. Install left side firewall (11), washer (23), and bolt (22) on left firewall.
10. Install angle bracket (12), six washers (14), and bolts (13) on left side firewall (11).
11. Install left side toe board (7), angle bracket (26), five washers (25), and bolts (24) on left firewall.
12. Install bracket (8), two washers (10), and bolts (9) on top of left side toe board (7).

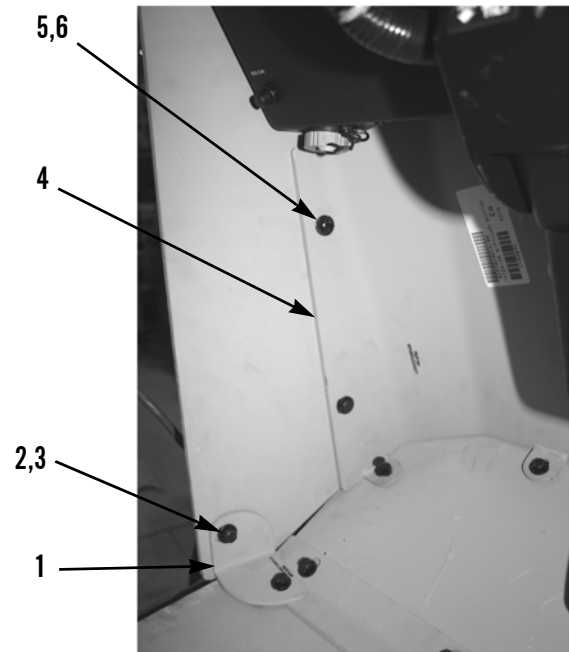


**FIREWALL ARMOR REPLACEMENT - CONTINUED**

0026 00

**INSTALLATION - CONTINUED**

13. Install A-pillar (4), four washers (6), and bolts (5) on bottom of A-pillar (4).
14. Install bracket (1), two washers (3), and bolts (2) on left firewall.



417-293

**END OF WORK PACKAGE**

---

**ESCAPE HATCH REPLACEMENT**

---

0027 00

**THIS WORK PACKAGE COVERS**Removal, Cleaning and Inspection, Installation

---

**INITIAL SETUP****Maintenance Level**

Unit

**Tools and Special Tools**

Tool Kit, General Mechanic's (Item 8, WP 0033 00)

**Materials/Parts**

Rag, Wiping (Item 6, WP 0034 00)

**References**

WP 0011 00

**Equipment Conditions****(M915A3P1, M916A3P1, and M917A2P1)**

Vehicle parked on level ground (TM 9-2320-302-10)

Parking/Emergency Brake applied (TM 9-2320-302-10)

Engine off (TM 9-2320-302-10)

Battery Disconnect Switch in OFF position (TM 9-2320-302-10)

**Equipment Conditions - Continued****(M915A4P1)**

Vehicle parked on level ground (TM 9-2320-303-10)

Parking/Emergency Brake applied (TM 9-2320-303-10)

Engine off (TM 9-2320-303-10)

Battery Disconnect Switch in OFF position (TM 9-2320-303-10)

**(M915A2P1, M916A1P1, M916A2P1, and M917A1P1)**

Vehicle parked on level ground (TM 9-2320-363-10)

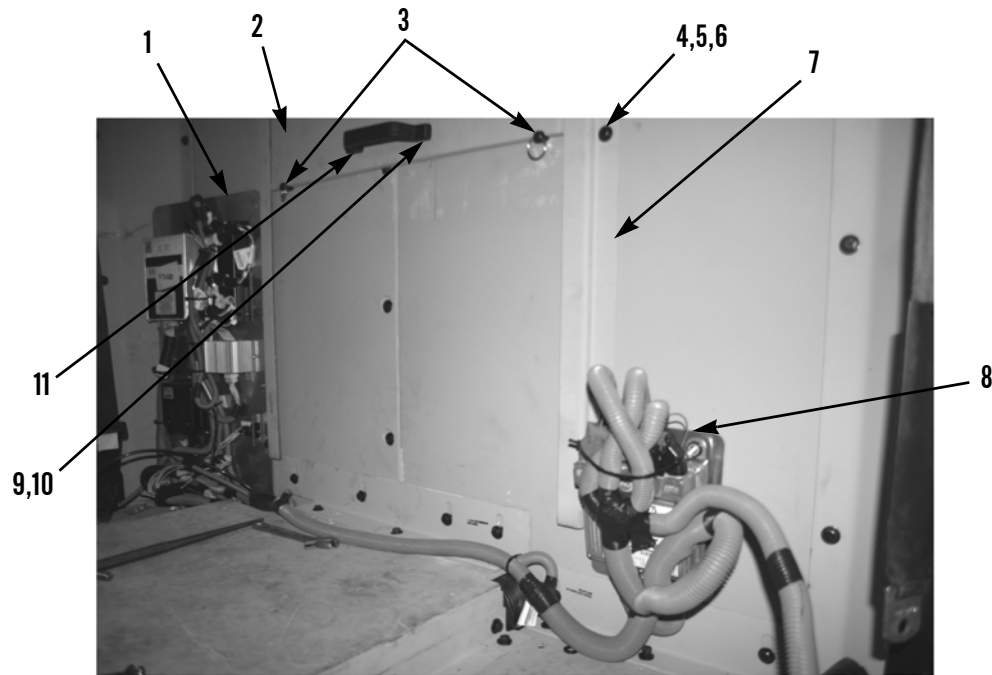
Parking/Emergency Brake applied (TM 9-2320-363-10)

Engine off (TM 9-2320-363-10)

If equipped, Battery Disconnect Switch in OFF position (TM 9-2320-363-10) otherwise, disconnect battery cables (TM 9-2320-363-20-2)

**ESCAPE HATCH REPLACEMENT - CONTINUED****0027 00****REMOVAL**

1. Remove two escape hatch retaining pins (3) and lower escape hatch (2).
2. Remove eight bolts (4), washers (5), washers (6), frame (7), and escape hatch (2) from rear wall of cab. Set aside panel (1) and panel (8).
3. Remove two bolts (9), washers (10), and handle (11) from escape hatch (2).



417-296

**CLEANING AND INSPECTION**

Clean and inspect all parts IAW *General Maintenance Instructions* (WP 0011 00).

**INSTALLATION**

1. Install handle (11), two washers (10), and bolts (9) on escape hatch (2).

**NOTE**

Install washers between frame and rear armor to allow escape hatch to move freely.

2. Install escape hatch (2), eight washers (6), frame (7), panel (1), panel (8), eight washers (5), and bolts (4) on rear wall of cab.
3. Raise escape hatch (2) and install two escape hatch retaining pins (3).

**END OF WORK PACKAGE**

---

**COWL ARMOR REPLACEMENT**

---

**0028 00****THIS WORK PACKAGE COVERS**Removal, Cleaning and Inspection, Installation

---

**INITIAL SETUP****Maintenance Level**

Unit

**Tools and Special Tools**

Tool Kit, General Mechanic's (Item 8, WP 0033 00)

**Materials/Parts**

Rag, Wiping (Item 6, WP 0034 00)

**References**

WP 0011 00

**Personnel Required**

Two

**Equipment Conditions****(M915A3P1, M916A3P1, and M917A2P1)**

Vehicle parked on level ground (TM 9-2320-302-10)

Parking/Emergency Brake applied (TM 9-2320-302-10)

Engine off (TM 9-2320-302-10)

Battery Disconnect Switch in OFF position (TM 9-2320-302-10)

Front Armor removed (WP 0029 00)

Windshield Ballistic Glass removed (WP 0025 00)

**Equipment Conditions - Continued****(M915A4P1)**

Vehicle parked on level ground (TM 9-2320-303-10)

Parking/Emergency Brake applied (TM 9-2320-303-10)

Engine off (TM 9-2320-303-10)

Battery Disconnect Switch in OFF position (TM 9-2320-303-10)

Front Armor removed (WP 0029 00)

Windshield Ballistic Glass removed (WP 0025 00)

**(M915A2P1, M916A1P1, M916A2P1, and M917A1P1)**

Vehicle parked on level ground (TM 9-2320-363-10)

Parking/Emergency Brake applied (TM 9-2320-363-10)

Engine off (TM 9-2320-363-10)

If equipped, Battery Disconnect Switch in OFF position (TM 9-2320-363-10) otherwise, disconnect battery cables (TM 9-2320-363-20-2)

Front Armor removed (WP 0029 00)

Windshield Ballistic Glass removed (WP 0025 00)

---

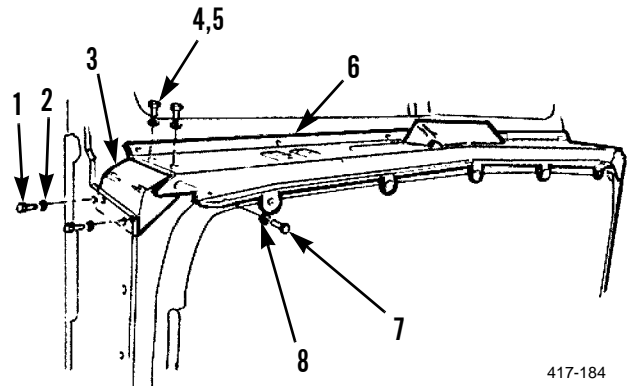
**REMOVAL****WARNING**

Use extreme caution when handling heavy parts. Provide adequate support and use assistance during procedure. Failure to follow this warning may cause injury or death to personnel.

**NOTE**

Cowl armor weighs 71 lb (32 kg).

1. With assistance, remove four bolts (1), washers (2), and cowl assembly (6) from vehicle.
2. Remove four bolts (4), washers (5), two bolts (7), washers (8), and right and left cowl corners welding (3) from cowl armor (6).



417-184

**CLEANING AND INSPECTION**

Clean and inspect all parts IAW *General Maintenance Instructions* (WP 0011 00).

**INSTALLATION**

1. Install right and left cowl corner weldings (3), two washers (8), bolts (7), four washers (5), and bolts (4) on cowl armor (6).

**WARNING**

Use extreme caution when handling heavy parts. Provide adequate support and use assistance during procedure. Failure to follow this warning may cause injury or death to personnel.

**NOTE**

Cowl armor weighs 71 lb (32 kg).

2. With assistance, install cowl armor assembly (6), four washers (2), and bolts (1) on vehicle.
3. Install front armor (WP 0029 00).
4. Install windshield ballistic glass (WP 0025 00).

**END OF WORK PACKAGE**



---

**FRONT ARMOR REPLACEMENT**

**0029 00**

---

**THIS WORK PACKAGE COVERS**

Removal, Cleaning and Inspection, Installation

---

**INITIAL SETUP**

**Maintenance Level**

Unit

**Tools and Special Tools**

Tool Kit, General Mechanic's (Item 8, WP 0033 00)

**Materials/Parts**

Rag, Wiping (Item 6, WP 0034 00)

**References**

WP 0011 00

**Personnel Required**

Two

**Equipment Conditions**

**(M915A3P1, M916A3P1, and M917A2P1)**

Vehicle parked on level ground (TM 9-2320-302-10)

Parking/Emergency Brake applied (TM 9-2320-302-10)

Engine off (TM 9-2320-302-10)

Battery Disconnect Switch in OFF position (TM 9-2320-302-10)

Hood open (TM 9-2320-302-10)

**Equipment Conditions - Continued**

**(M915A4P1)**

Vehicle parked on level ground (TM 9-2320-303-10)

Parking/Emergency Brake applied (TM 9-2320-303-10)

Engine off (TM 9-2320-303-10)

Battery Disconnect Switch in OFF position (TM 9-2320-303-10)

Hood open (TM 9-2320-303-10)

**(M915A2P1, M916A1P1, M916A2P1, and M917A1P1)**

Vehicle parked on level ground (TM 9-2320-363-10)

Parking/Emergency Brake applied (TM 9-2320-363-10)

Engine off (TM 9-2320-363-10)

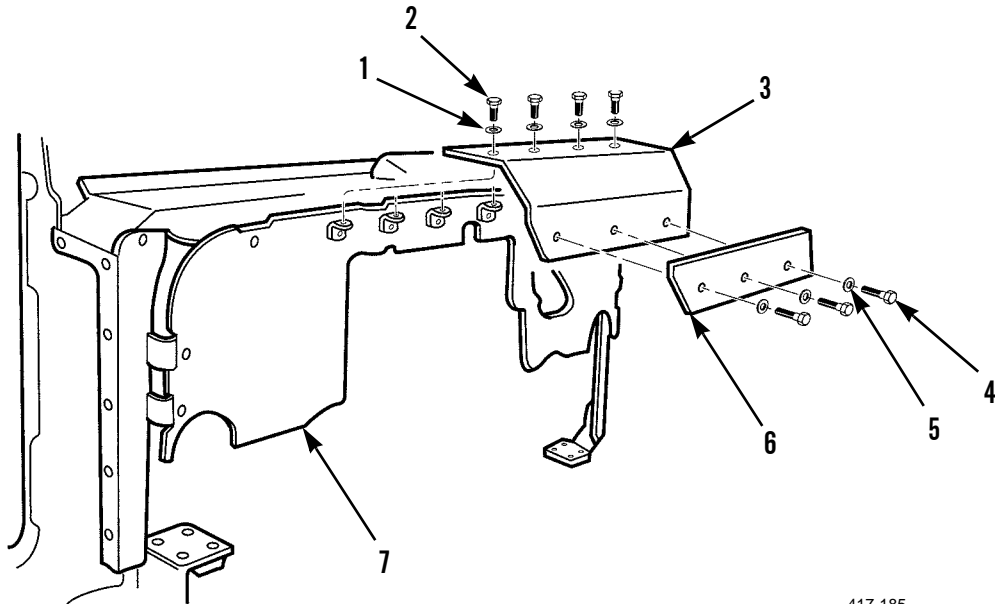
If equipped, Battery Disconnect Switch in OFF position (TM 9-2320-363-10) otherwise, disconnect battery cables (TM 9-2320-363-20-2)

Hood open (TM 9-2320-363-10)

---

**REMOVAL**

1. Remove three bolts (4), washers (5), and overlap (6) from air filter armor (3).
2. Remove four bolts (2), washers (1), and air filter armor (3) from front armor (7).



417-185

**WARNING**

Use extreme caution when handling heavy parts. Provide adequate support and use assistance during procedure. Failure to follow this warning may cause injury or death to personnel.

**NOTE**

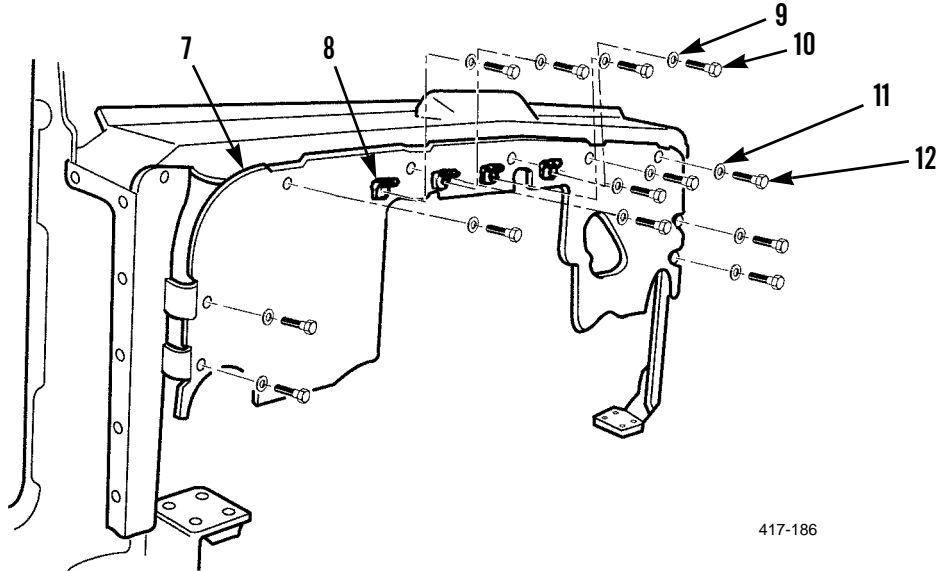
Front armor weighs 141 lb (64 kg).

**FRONT ARMOR REPLACEMENT - CONTINUED**

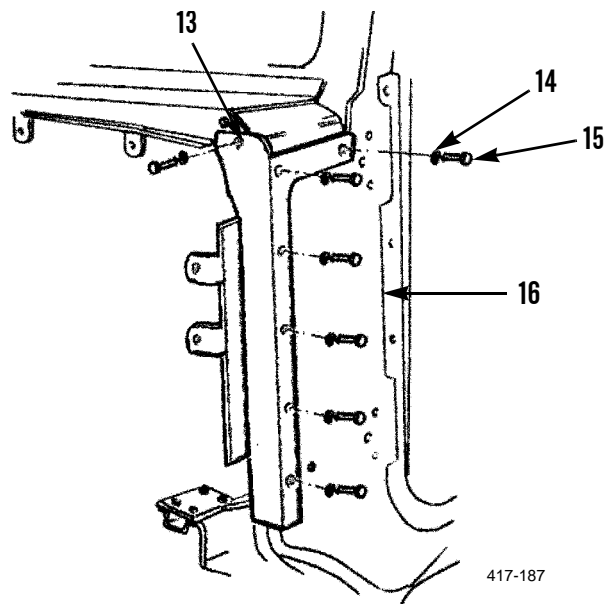
0029 00

**REMOVAL - CONTINUED**

3. Remove four bolts (10), washers (8), and four brackets (8) from front armor (7).
4. With assistance, remove nine bolts (12), washers (11), and front armor (7) from vehicle.



5. Remove seven bolts (15), washers (14), and front side left welding (13) from side armor (16).

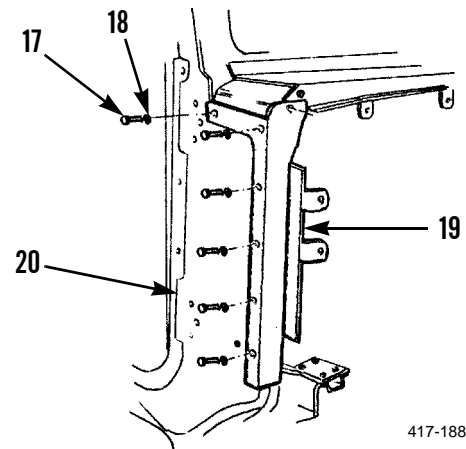


**FRONT ARMOR REPLACEMENT - CONTINUED**

0029 00

**REMOVAL - CONTINUED**

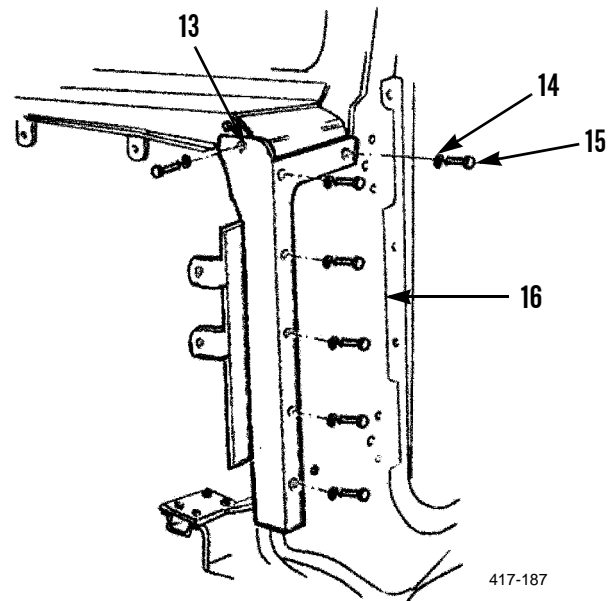
6. Remove seven bolts (17), washers (18), and front side right welding (19) from side armor (20).

**CLEANING AND INSPECTION**

Clean and inspect all parts IAW *General Maintenance Instructions* (WP 0011 00).

**INSTALLATION**

1. Install front side right welding (19), six washers (18), and bolts (17) on side armor (20).
2. Install front side left welding (13), six washers (14), and bolts (15) on side armor (16).



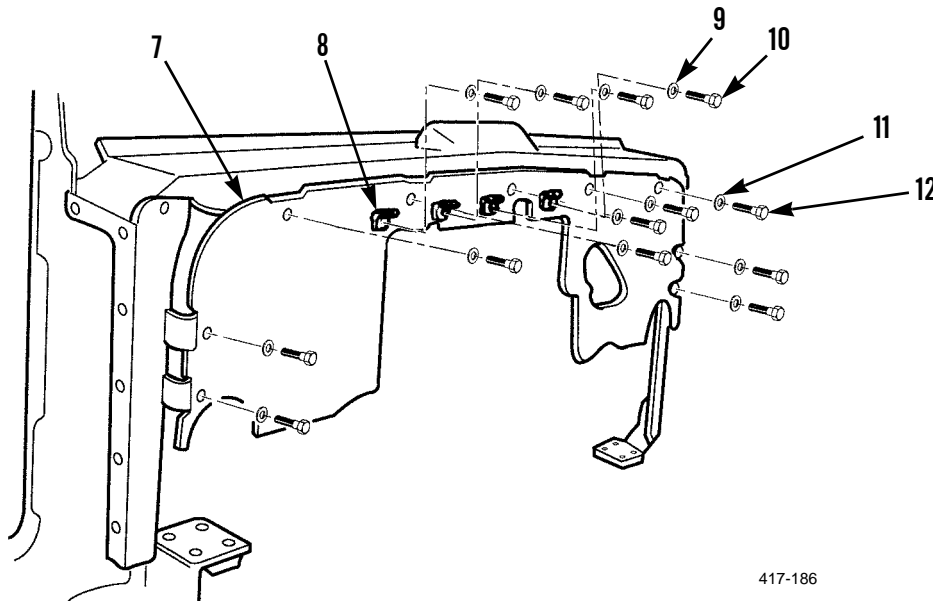
**INSTALLATION - CONTINUED****WARNING**

Use extreme caution when handling heavy parts. Provide adequate support and use assistance during procedure. Failure to follow this warning may cause injury or death to personnel.

**NOTE**

Front armor weighs 141 lb (64 kg).

3. Install four brackets (8), four washers (9), and bolts (10) on front armor (7).
4. With assistance, install front armor (7), nine washers (11), and bolts (12) on vehicle.



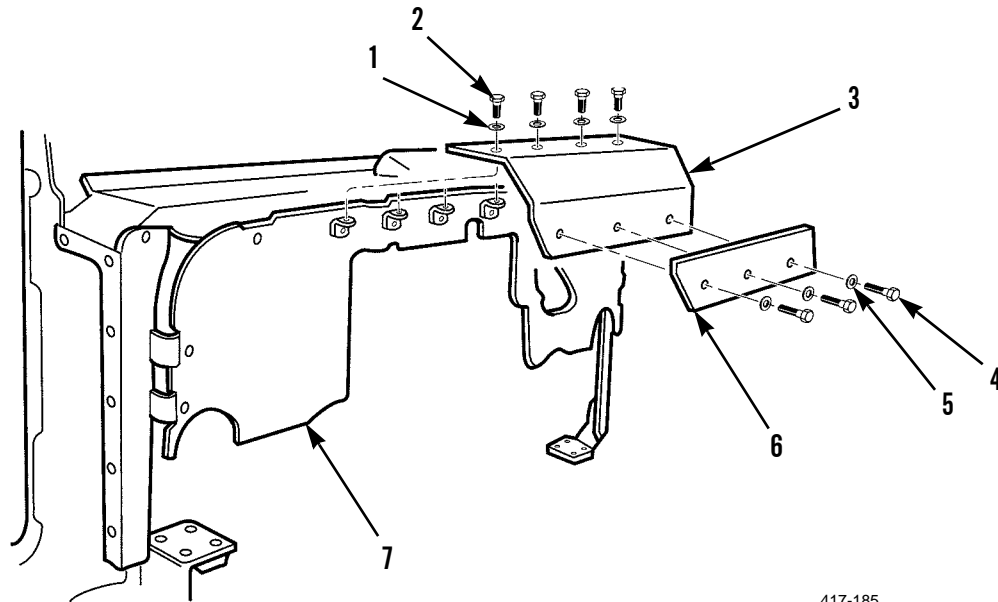
417-186

**FRONT ARMOR REPLACEMENT - CONTINUED**

0029 00

**INSTALLATION - CONTINUED**

5. Install air filter armor (3), four washers (1), and bolts (2) on front armor (7).
6. Install overlap (6), three washers (5), and bolts (4) on air filter armor (3).



7. Close hood. For the M915A3P1, M916A3P1, and M917A2P1, refer to TM 9-2320-302-10. For the M915A4P1, refer to TM 9-2320-303-10. For the M915A2P1, M916A1P1, M916A2P1, and M917A1P1, refer to TM 9-2320-363-10.

**END OF WORK PACKAGE**

---

**FOAM INSULATION REPLACEMENT**

**0030 00**

---

**THIS WORK PACKAGE COVERS**

Removal, Cleaning and Inspection, Installation

---

**INITIAL SETUP**

**Maintenance Level**

Unit

**Tools and Special Tools**

Tool Kit, General Mechanic's (Item 8, WP 0033 00)

**Materials/Parts**

Rag, Wiping (Item 6, WP 0034 00)

**References**

WP 0011 00

**Equipment Conditions**

**(M915A3P1, M916A3P1, and M917A2P1)**

Vehicle parked on level ground (TM 9-2320-302-10)

Parking/Emergency Brake applied (TM 9-2320-302-10)

Engine off (TM 9-2320-302-10)

Battery Disconnect Switch in OFF position (TM 9-2320-302-10)

**Equipment Conditions - Continued**

**(M915A4P1)**

Vehicle parked on level ground (TM 9-2320-303-10)

Parking/Emergency Brake applied (TM 9-2320-303-10)

Engine off (TM 9-2320-303-10)

Battery Disconnect Switch in OFF position (TM 9-2320-303-10)

**(M915A2P1, M916A1P1, M916A2P1, and M917A1P1)**

Vehicle parked on level ground (TM 9-2320-363-10)

Parking/Emergency Brake applied (TM 9-2320-363-10)

Engine off (TM 9-2320-363-10)

If equipped, Battery Disconnect Switch in OFF position (TM 9-2320-363-10) otherwise, disconnect battery cables (TM 9-2320-363-20-2)

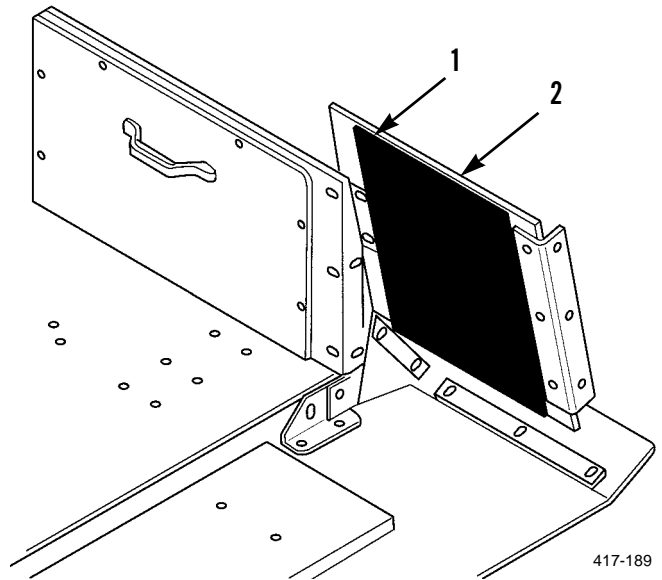
---

**FOAM INSULATION REPLACEMENT - CONTINUED**

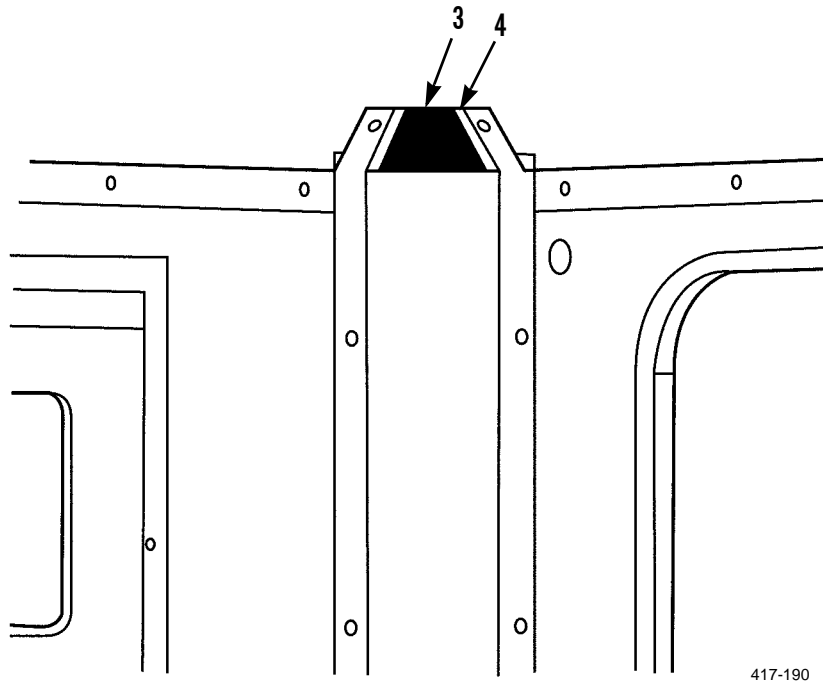
0030 00

**REMOVAL**

1. Remove foam insulation panel (1) from right firewall panel (2).



2. Remove foam insulation panel (3) from left rear corner (4).



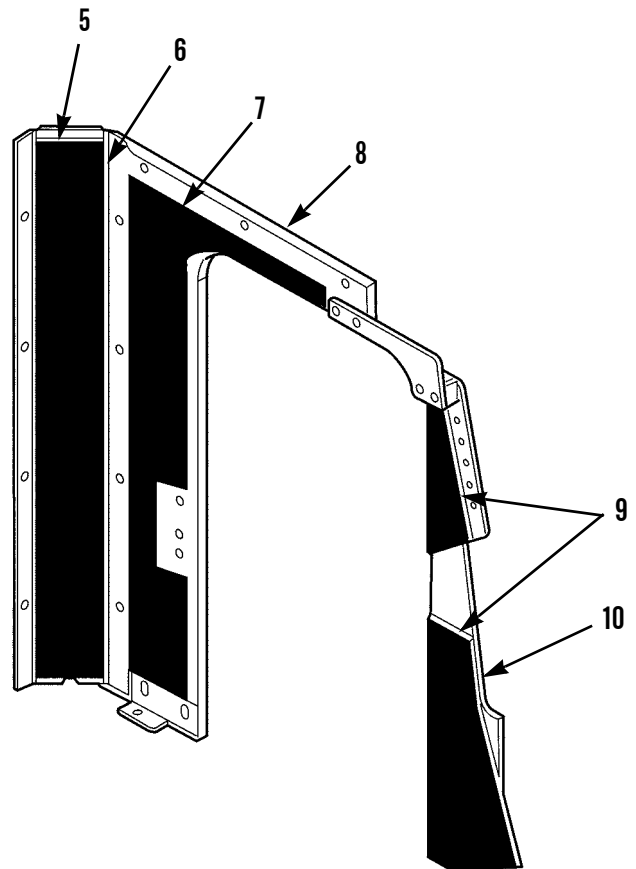


**FOAM INSULATION REPLACEMENT - CONTINUED**

0030 00

**REMOVAL - CONTINUED**

3. Remove foam insulation panel (5) from left rear B-pillar armor (6).
4. Remove foam insulation panel (7) from left side armor (8).
5. Remove two foam insulation panels (9) from left A-pillar armor (10).



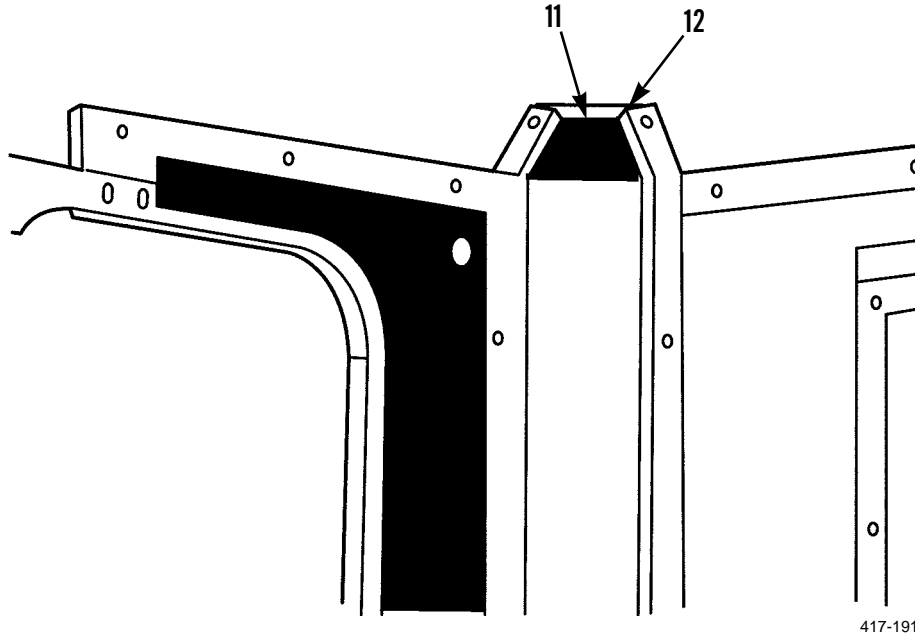
417-194

## FOAM INSULATION REPLACEMENT - CONTINUED

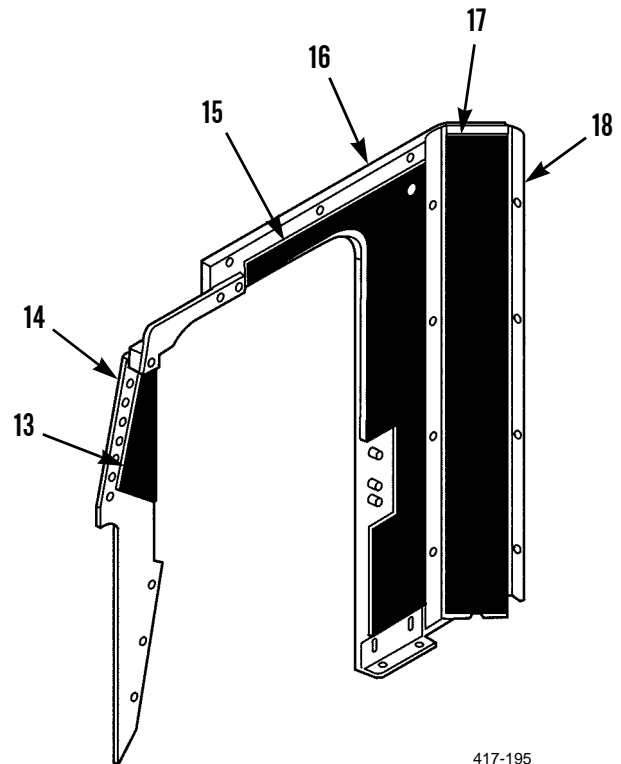
0030 00

**REMOVAL - CONTINUED**

6. Remove foam insulation panel (11) from right rear corner (12).

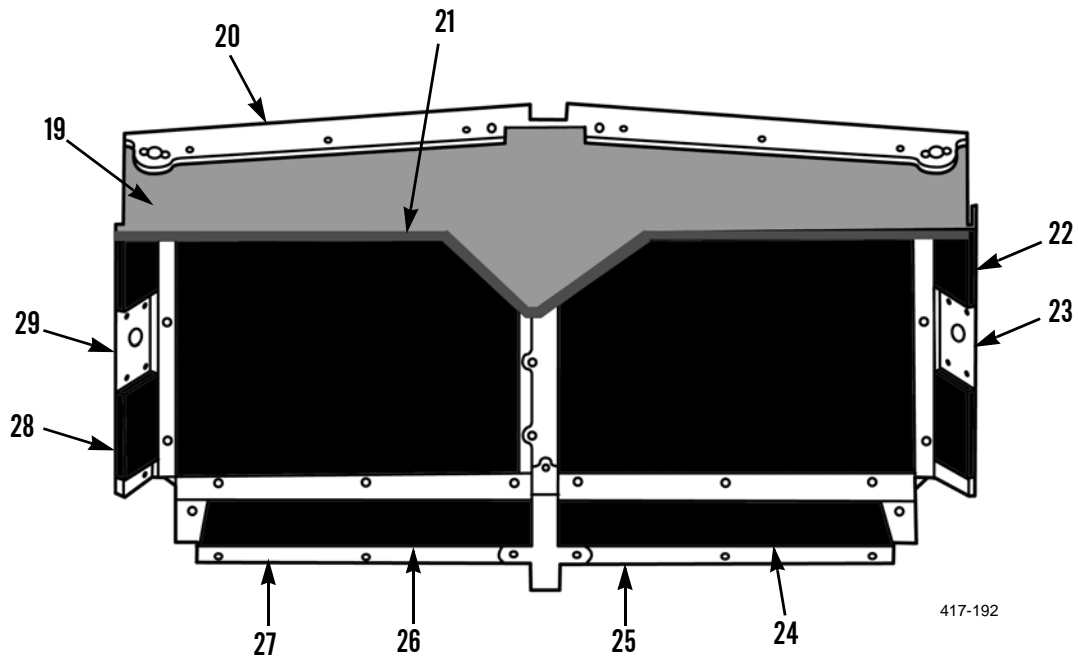


7. Remove foam insulation panel (17) from right rear B-pillar armor (18).
8. Remove foam insulation panel (15) from right side armor (16).
9. Remove foam insulation panel (13) from right A-pillar armor (14).



**FOAM INSULATION REPLACEMENT - CONTINUED****0030 00****REMOVAL - CONTINUED**

10. Remove foam insulation panel (19) from front roof panel (20).
11. Remove foam insulation panel (21) from front roof panel (20).
12. Remove foam insulation panel (22) from left roof overlap (23).
13. Remove foam insulation panel (28) from right roof overlap (29).
14. Remove foam insulation panel (24) from left backside roof bar (25).
15. Remove foam insulation panel (26) from right backside roof bar (27).

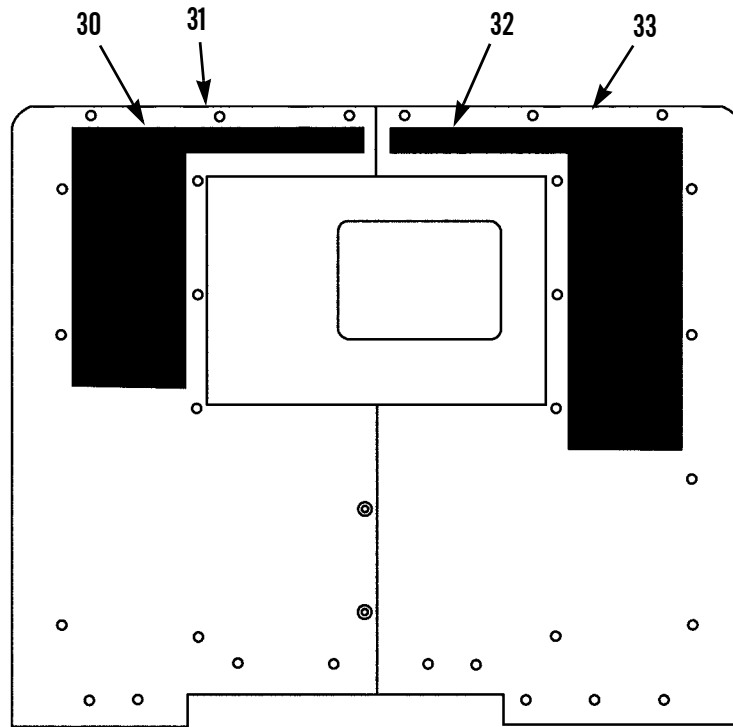


**FOAM INSULATION REPLACEMENT - CONTINUED**

0030 00

**REMOVAL - CONTINUED**

16. Remove foam insulation panel (30) from right rear wall armor (31).
17. Remove foam insulation panel (32) from left rear wall armor (33).



417-193

**CLEANING AND INSPECTION**

Clean and inspect all parts IAW *General Maintenance Instructions* (WP 0011 00).

**INSTALLATION**

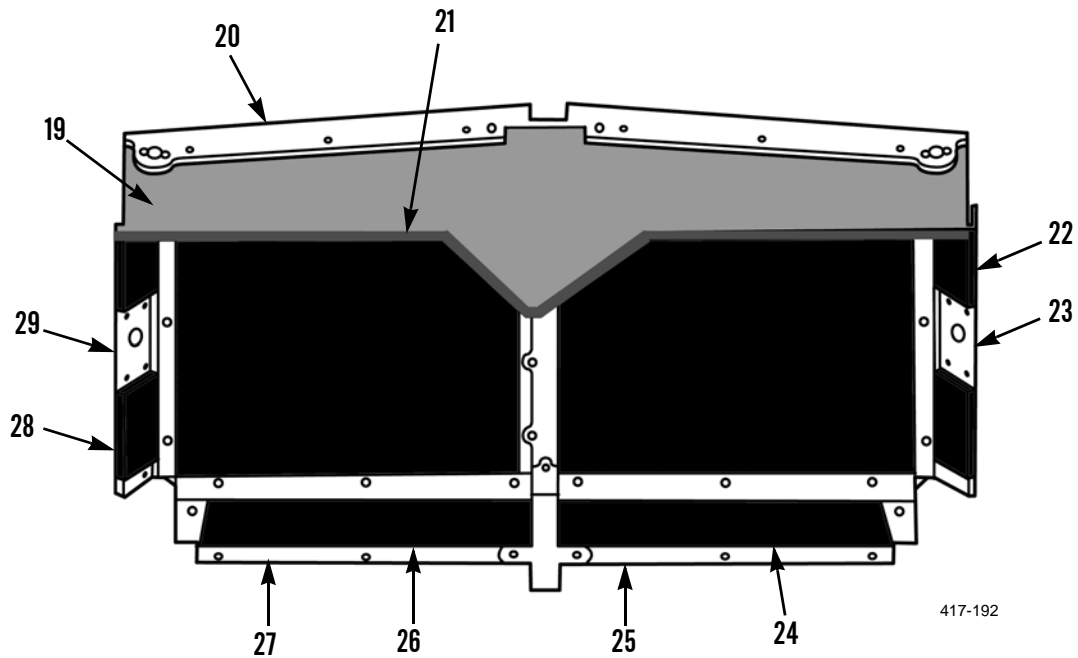
1. Install foam insulation panel (32) on left rear wall armor (33).
2. Install foam insulation panel (30) on right rear wall armor (31).

**FOAM INSULATION REPLACEMENT - CONTINUED**

0030 00

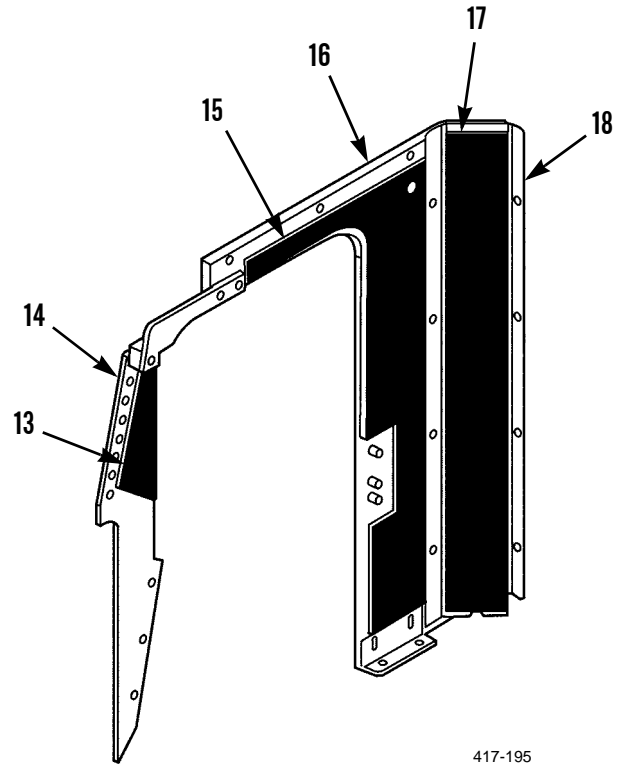
**INSTALLATION - CONTINUED**

3. Install foam insulation panel (26) on right backside roof bar (27).
4. Install foam insulation panel (24) on left backside roof bar (25).
5. Install foam insulation panel (28) on right roof overlap (29).
6. Install foam insulation panel (22) on left roof overlap (23).
7. Install foam insulation panel (21) on front roof panel (20).
8. Install foam insulation panel (19) on front roof panel (20).



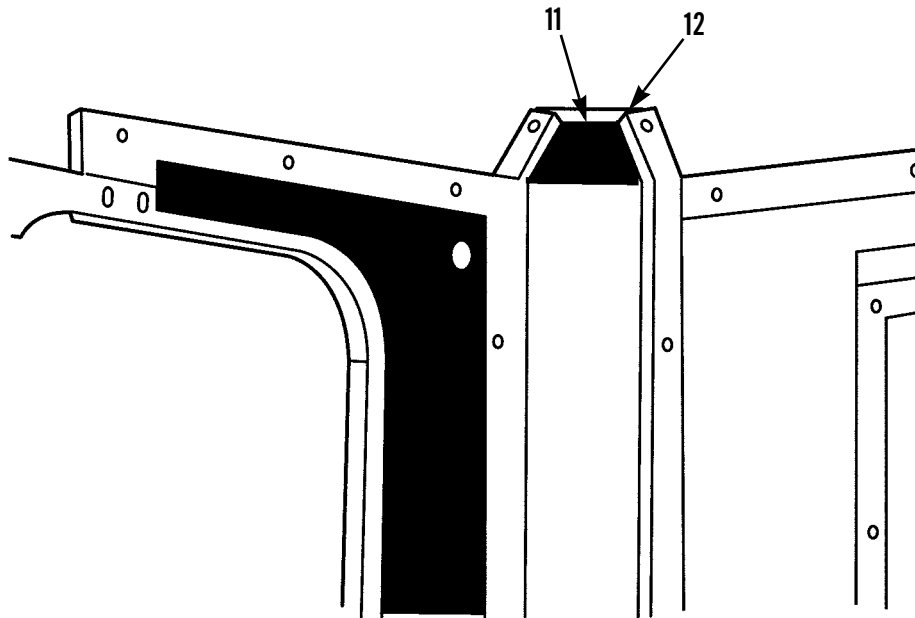
**INSTALLATION - CONTINUED**

9. Install foam insulation panel (13) on right A-pillar armor (14).
10. Install foam insulation panel (15) on right side armor (16).
11. Install foam insulation panel (17) on right rear B-pillar armor (18).



417-195

12. Install foam insulation panel (11) on right rear corner (12).



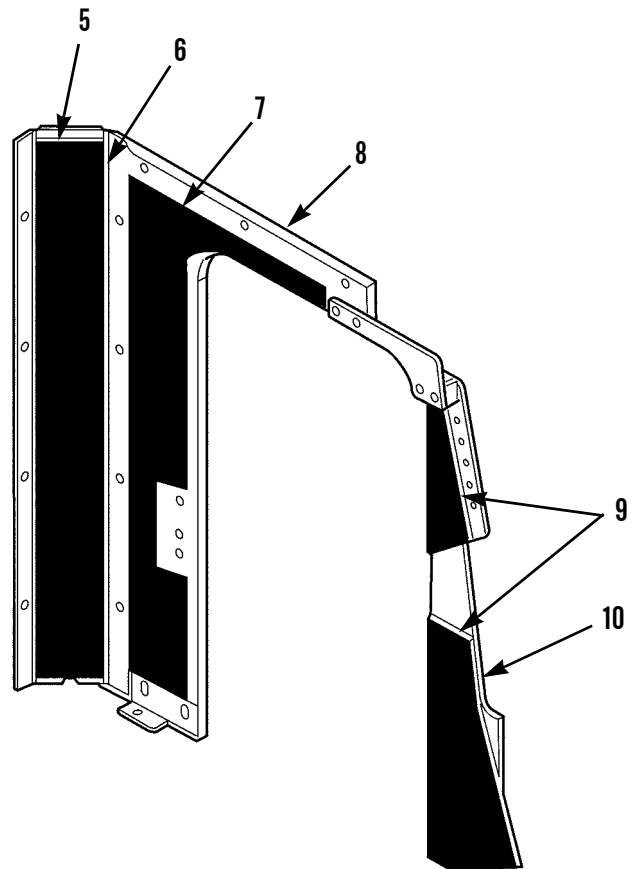
417-191

**FOAM INSULATION REPLACEMENT - CONTINUED**

0030 00

**INSTALLATION - CONTINUED**

13. Remove two foam insulation panels (9) from left A-pillar armor (10).
14. Remove foam insulation panel (7) from left side armor (8).
15. Remove foam insulation panel (5) from left rear B-pillar armor (6).



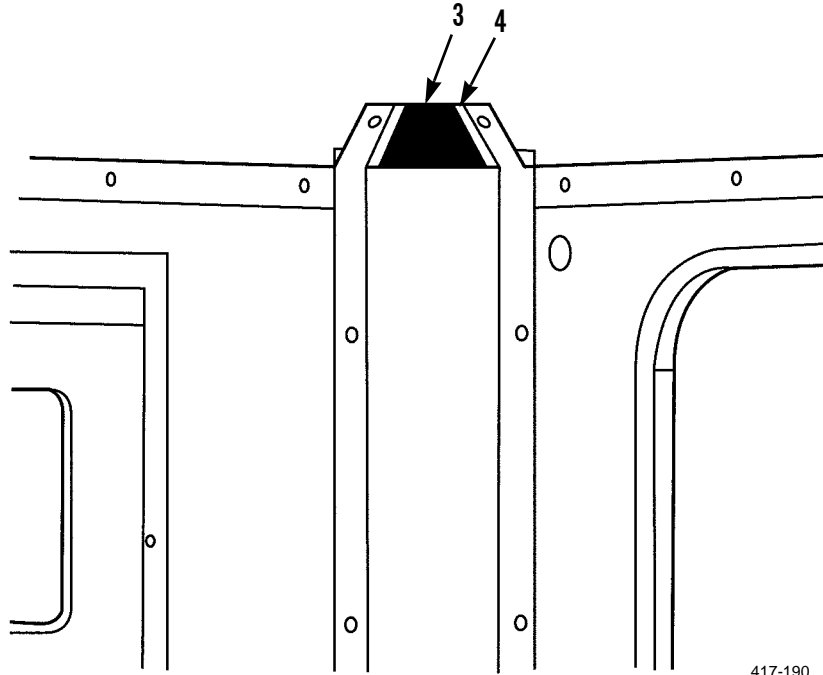
417-194

**FOAM INSULATION REPLACEMENT - CONTINUED**

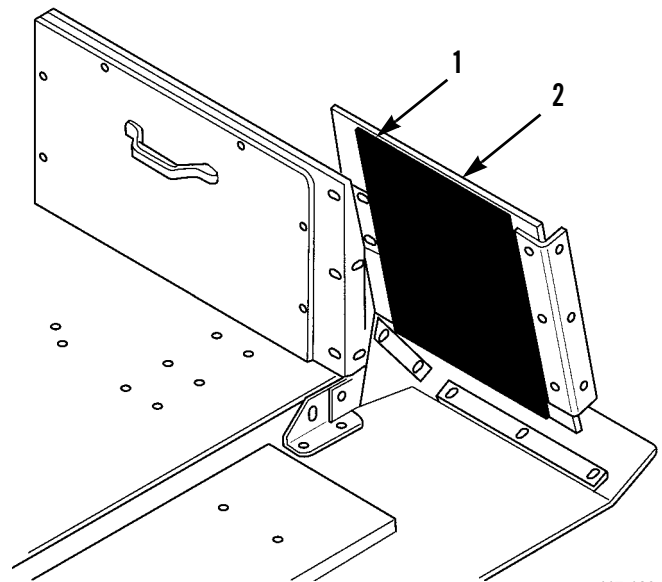
**0030 00**

**INSTALLATION - CONTINUED**

16. Install foam insulation panel (3) on left rear corner (4).



17. Install foam insulation panel (1) on right firewall panel (2).



**END OF WORK PACKAGE**



**CHAPTER 5**  
**SUPPORTING INFORMATION**



**REFERENCES**

**0031 00**

**SCOPE**

This work package lists all publication indexes, forms, field manuals, technical bulletins, technical manuals, and other publications that are referenced in this bulletin and that apply to operation and maintenance of the Crew Protection Kit.

**PUBLICATION INDEXES**

The following indexes should be consulted frequently for latest changes or revisions and for new publications relating to material covered in this technical bulletin.

- Consolidated Army Publications and Forms Index. . . . . DA PAM 25-30
- Functional Users Manual for The Army Maintenance Management System (TAMMS). . . . . DA PAM 750-8

**FORMS**

**NOTE**

Refer to DA PAM 750-8, *Functional Users Manual for The Army Maintenance Management System (TAMMS)*, for instructions on the use of maintenance forms.

- Equipment Inspection and Maintenance Worksheet . . . . . DA Form 2404, DA Form 5988-E
- Product Quality Deficiency Report. . . . . SF Form 368
- Recommended Changes to Publications and Blank Forms. . . . . DA Form 2028

**FIELD MANUALS**

- First Aid. . . . . FM 4-25.11

**TECHNICAL BULLETINS**

- CARC Spot Painting . . . . . TB 43-0242
- Color, Marking, and Camouflage Painting of Military Vehicles, Construction Equipment, and Materials Handling Equipment. . . . . TB 43-0209

**TECHNICAL MANUALS**

- Direct Support and General Support Maintenance Manual for Truck, Tractor, M915A3 Line-Haul . . . . . TM 9-2320-302-34
- Materials Used for Cleaning, Preserving, Abrading, and Cementing Ordnance Materiel and Related Materiels Including Chemicals . . . . . TM 9-247
- Operator’s Manual for Truck, Tractor, Line-Haul: 52,000 GVWR, 6 X 4, M915A2. . . . . TM 9-2320-363-10
- Operator’s Manual for Truck, Tractor, Line-Haul: 52,000 GVWR, 6 X 4, M915A3. . . . . TM 9-2320-302-10
- Operator’s Manual for Truck, Tractor, Line-Haul: 52,000 GVWR, 6 X 4, M915A4. . . . . TM 9-2320-303-10
- Operator’s Manual for Truck, Tractor, Light Equipment Transporter (LET): 68,000 GVWR, 6 X 6, W/Winch, M916A1 . . . . . TM 9-2320-363-10
- Operator’s Manual for Truck, Tractor, Light Equipment Transporter (LET): 68,000 GVWR, 6 X 6, W/Winch, M916A2 . . . . . TM 9-2320-363-10
- Operator’s Manual for Truck, Tractor, Light Equipment Transporter (LET): 68,000 GVWR, 6 X 6, W/Winch, M916A3 . . . . . TM 9-2320-302-10
- Operator’s Manual for Truck, Dump, Heavy, Chassis: 68,000 GVWR, 6 X 6, 14 CU YD, On-Off Highway, M917A1 . . . . . TM 9-2320-363-10
- Operator’s Manual for Truck, Dump, Heavy, Chassis: 68,000 GVWR, 6 X 6, 14 CU YD, On-Off Highway, M917A2 . . . . . TM 9-2320-302-10

**REFERENCES - CONTINUED**

**0031 00**

**TECHNICAL MANUALS - CONTINUED**

Procedures for Destruction of Tank-automotive Equipment to Prevent Enemy Use  
(U. S. Army Tank-automotive Command) . . . . . TM 750-244-6

Unit, Direct Support, and General Support Including Depot Maintenance for Truck,  
Tractor, Line-Haul: 52,000 GVWR, 6 X 4, M915A4 . . . . . TM 9-2320-303-24

Unit, Direct Support, and General Support Including Depot Maintenance RPSTL for Truck,  
Tractor, M915A3 Line-Haul . . . . . TM 9-2320-302-24P

Unit, Direct Support, and General Support Including Depot Maintenance RPSTL for Truck,  
Tractor, Line Haul: 52,000 GVWR, 6 X 4, M915A2 . . . . . TM 9-2320-363-24P

Unit, Direct Support, and General Support Including Depot Maintenance RPSTL for Truck,  
Tractor, Light Equipment Transporter (LET): 68,000 GVWR, 6 X 6, W/Winch, M916A1 . . . . . TM 9-2320-363-24P

Unit, Direct Support, and General Support Including Depot Maintenance RPSTL for Truck,  
Tractor, Light Equipment Transporter (LET): 68,000 GVWR, 6 X 6, W/Winch, M916A2 . . . . . TM 9-2320-363-24P

Unit, Direct Support, and General Support Including Depot Maintenance RPSTL for Truck,  
Dump, Heavy Chassis: 68,000 GVWR, 6 X 6, 14 cu. yd., On-Off Highway, M917A1, and  
M917A1 W/MCS . . . . . TM 9-2320-363-24P

Unit, Direct Support, and General Support Including Depot Maintenance RPSTL for Truck,  
Tractor, M915A4 Line-Haul . . . . . TM 9-2320-303-24P

Unit Maintenance Manual for Truck, Tractor, Line-Haul: 52,000 GVWR, 6 X 4, M915A2 . . . . . TM 9-2320-363-20

Unit Maintenance Manual for Truck, Tractor, Line-Haul: 52,000 GVWR, 6 X 4, M915A3 . . . . . TM 9-2320-302-20

Unit Maintenance Manual for Truck, Tractor, Light Equipment Transporter (LET): 68,000 GVWR, 6 X 6,  
W/Winch, M916A1 . . . . . TM 9-2320-363-20

Unit Maintenance Manual for Truck, Tractor, Light Equipment Transporter (LET): 68,000 GVWR, 6 X 6,  
W/Winch, M916A2 . . . . . TM 9-2320-363-20

Unit Maintenance Manual for Truck, Tractor, Light Equipment Transporter (LET): 68,000 GVWR, 6 X 6,  
W/Winch, M916A3 . . . . . TM 9-2320-302-20

Unit Maintenance Manual for Truck, Dump, Heavy, Chassis: 68,000 GVWR, 6 X 6, 14 CU YD,  
On-Off Highway, M917A1 . . . . . TM 9-2320-363-20

Unit Maintenance Manual for Truck, Dump, Heavy, Chassis: 68,000 GVWR, 6 X 6, 14 CU YD,  
On-Off Highway, M917A2 . . . . . TM 9-2320-302-20

**OTHER PUBLICATIONS**

Standard Abbreviations . . . . . ASME Y14.38-1999

Army Medical Department Expendable/Durable Items . . . . . CTA 8-100

Expendable/Durable Items (Except Medical, Class V, Repair Parts, and Heraldic Items) . . . . . CTA 50-970

**END OF WORK PACKAGE**

**THE ARMY MAINTENANCE SYSTEM MAC**

1. This introduction provides a general explanation of all maintenance and repair functions authorized at the two maintenance levels under the Two-Level Maintenance System concept.
2. The MAC immediately following this introduction designates overall authority and responsibility for the performance of maintenance functions on the identified end item or component. The application of the maintenance functions to the end item or component shall be consistent with the capacities and capabilities of the designated maintenance levels, which are shown in the MAC (WP 0033 00) in column (4) as:

Field - includes subcolumns:

C - Operator/Crew

O - Unit

F - Direct Support

Sustainment - includes subcolumns:

H - General Support

D - Depot

3. The tools and test equipment requirements (immediately following the MAC) list the tools and test equipment (both special tools and common tool sets) required for each maintenance function as referenced from the MAC.
4. The remarks (immediately following the tools and test equipment requirements) contain supplemental instructions and explanatory notes for a particular maintenance function.

**MAINTENANCE FUNCTIONS**

Maintenance functions are limited to and defined as follows:

1. **Inspect.** To determine the serviceability of an item by comparing its physical, mechanical, and/or electrical characteristics with established standards through examination (e.g., by sight, sound, or feel).
2. **Test.** To verify serviceability by measuring the mechanical, pneumatic, hydraulic, or electrical characteristics of an item and comparing those characteristics with prescribed standards on a scheduled basis, i.e., load testing of lift devices and hydrostatic testing of pressure hoses.
3. **Service.** Operations required periodically to keep an item in proper operating condition; e.g., to clean (includes decontaminate, when required), preserve, drain, paint, or replenish fuel, lubricants, chemical fluids, or gases.
4. **Adjust.** To maintain or regulate, within prescribed limits, by bringing into proper position, or by setting the operating characteristics to specified parameters.
5. **Align.** To adjust specified variable elements of an item to bring about optimum or desired performance.
6. **Calibrate.** To determine and cause corrections to be made or to be adjusted on instruments of test, measuring, and diagnostic equipment used in precision measurement. Calibration consists of comparisons of two instruments, one of which is a certified standard of known accuracy, to detect and adjust any discrepancy in the accuracy of the instrument being compared.
7. **Remove/Install.** To remove and install the same item when required to perform service or other maintenance functions. Installation may be the act of emplacing or seating a spare, repair part, or module (component or assembly) into position in a manner to allow the proper functioning of an equipment or system.
8. **Replace.** To remove an unserviceable item and install a serviceable counterpart in its place. Replacement is authorized by the MAC and the assigned maintenance level is shown as the third position code of the Source, Maintenance, and Recoverability (SMR) code.
9. **Repair.** Repair is the application of maintenance services, including fault location/troubleshooting, removal/installation, disassembly/assembly procedures, and maintenance actions to identify troubles and restore serviceability to an item by correcting specific damage, fault, malfunction, or failure in a part, subassembly, module (component or assembly), end item, or system.

**MAINTENANCE FUNCTIONS - CONTINUED****NOTE**

The following definitions are applicable to the "repair" maintenance function:

- Services - Inspecting, testing, service, adjustment, alignment, calibration, and/or replacement.
  - Fault location/troubleshooting - The process of investigating and detecting the cause of equipment malfunctioning; the act of isolating a fault within a system or Unit Under Test (UUT).
  - Disassembly/assembly - The step-by-step breakdown (taking apart) of a spare/functional group coded item to the level of its least component, assigned a SMR code for the level of maintenance under consideration (i.e., identified as maintenance significant).
  - Actions - Welding, grinding, riveting, straightening, facing, machining, and/or resurfacing.
10. **Overhaul.** That maintenance effort (service/action) prescribed to restore an item to a completely serviceable/operational condition as required by maintenance standards in appropriate technical publications. Overhaul is normally the highest degree of maintenance performed by the Army. Overhaul does not normally return an item to like new condition.
11. **Rebuild.** Consists of those services/actions necessary for the restoration of unserviceable equipment to a like new condition in accordance with original manufacturing standards. Rebuild is the highest degree of materiel maintenance applied to Army equipment. The rebuild operation includes the act of returning to zero those age measurements (hours/miles, etc.) considered in classifying Army equipment/components.

**EXPLANATION OF COLUMNS IN THE MAC, TABLE 1**

1. **Column (1) - Group Number.** Column (1) lists Group numbers, the purpose of which is to identify maintenance significant components, assemblies, subassemblies, and modules with the Next Higher Assembly (NHA).
2. **Column (2) - Component/Assembly.** Column (2) contains the item names of components, assemblies, subassemblies, and modules for which maintenance is authorized.
3. **Column (3) - Maintenance Function.** Column (3) lists the functions to be performed on the item listed in Column (2). (For a detailed explanation of these functions refer to "Maintenance Functions" outlined above).
4. **Column (4) - Maintenance Level.** Column (4) specifies each level of maintenance authorized to perform each function listed in column (3), by indicating work time required (expressed as manhours in whole hours or decimals) in the appropriate subcolumn. This work time figure represents the active time required to perform that maintenance function at the indicated level of maintenance. If the number or complexity of the tasks within the listed maintenance function varies at different maintenance levels, appropriate work time figures are to be shown for each level. The work time figure represents the average time required to restore an item (assembly, subassembly, component, module, end item, or system) to a serviceable condition under typical field operating conditions. This time includes preparation time (including any necessary disassembly/assembly time), troubleshooting/fault location time, and quality assurance time in addition to the time required to perform the specific tasks identified for the maintenance functions authorized in the MAC. The symbol designations for the various maintenance levels are as follows:

Field:

- C - Operator/Crew Maintenance
- O - Unit Maintenance
- F - Direct Support Maintenance

Sustainment:

- H - General Support Maintenance
- D - Depot Maintenance

**EXPLANATION OF COLUMNS IN THE MAC, TABLE 1- CONTINUED****NOTE**

The "L" maintenance level is not included in column (4) of the MAC. Functions to this level of maintenance are identified by a work time figure in the "H" column of column (4), and an associated reference code is used in the REMARKS CODE column (6). This code is keyed to the remarks, and the SRA complete repair application is explained there.

5. **Column (5) - Tools and Equipment Reference Code.** Column (5) specifies, by code, common tool sets (not individual tools), common Test, Measurement, and Diagnostic Equipment (TMDE), special tools, special TMDE, and special support equipment required to perform the designated function. Codes are keyed to the entries in the tools and test equipment table.
6. **Column (6) - Remarks Code.** When applicable, this column contains a letter code, in alphabetical order, which is keyed to the remarks table entries (Table 3).

**EXPLANATION OF COLUMNS IN THE TOOLS AND TEST EQUIPMENT REQUIREMENTS, TABLE 2**

1. **Column (1) - Tool or Test Equipment Reference Code.** The tool and test equipment reference code correlates with a code used in column (5) of the MAC.
2. **Column (2) - Maintenance Level.** The lowest level of maintenance authorized to use the tool or test equipment.
3. **Column (3) - Nomenclature.** Name or identification of the tool or test equipment.
4. **Column (4) - National Stock Number (NSN).** The NSN of the tool or test equipment.
5. **Column (5) - Tool Number.** The manufacturer's part number, model number, or type number.

**EXPLANATION OF COLUMNS IN THE REMARKS, TABLE 3**

1. **Column (1) - Remarks Code.** The code recorded in column (6) of the MAC.
2. **Column (2) - Remarks.** This column lists information pertinent to the maintenance function being performed as indicated in the MAC.

**END OF WORK PACKAGE**





MAINTENANCE ALLOCATION CHART (MAC)

0033 00

Table 1. MAC for the Crew Protection Kit

(1) GROUP NUMBER	(2) COMPONENT/ ASSEMBLY	(3) MAINTENANCE FUNCTION	(4) MAINTENANCE LEVEL				(5) TOOLS AND EQUIPMENT REF CODE	(6) REMARKS CODE	
			FIELD		SUSTAINMENT				
			UNIT		DS	GS			DEPOT
			C	O	F	H			D
33	<b>SPECIAL PURPOSE KITS</b>								
3307	Crew Protection Kit:	Install		46.0			8		
	Vehicle Preparation			16.0					
	A-Pillar Armor	Inspect	0.2					A	
		Install		2.0			8		
		Replace		2.0			8		
	Cab Support	Inspect	0.2					A	
	Reinforcement	Install		2.0			5,6,7,8		
		Replace		2.0			5,6,7,8		
	Cowl Armor	Inspect	0.2					A	
		Install		2.0			5,6,7,8		
		Replace		2.0			5,6,7,8		
	Door Assembly	Inspect	0.2					A	
		Service	0.2					B	
		Install		2.5			5,6,7,8		
		Replace		2.5			5,6,7,8		
	Door Handle	Inspect	0.2					A	
	Assembly	Install		1.0			8		
		Replace		1.0			8		
	Door Latch	Inspect	0.2					A	
		Install		1.0			8		
		Replace		1.0			8		
	Door Ballistic Glass	Inspect	0.2					A	
	and Frame Assembly	Service	0.2					B	
		Replace		2.0			8		
	Door Latch	Inspect	0.2					A	
	Adjustment	Service		0.5			8		
	Escape Hatch	Inspect	0.2					A	
		Install		2.5			8		
		Replace		2.5			8		
	Floor Armor	Inspect	0.2					A	
		Install		3.0			8		
		Replace		3.0			8		
	Firewall Armor	Inspect	0.2					A	
		Install		3.0			8		
		Replace		3.0			8		

MAINTENANCE ALLOCATION CHART (MAC) - CONTINUED

0033 00

Table 1. MAC for the Crew Protection Kit - Continued.

(1) GROUP NUMBER	(2) COMPONENT/ ASSEMBLY	(3) MAINTENANCE FUNCTION	(4) MAINTENANCE LEVEL				(5) TOOLS AND EQUIPMENT REF CODE	(6) REMARKS CODE				
			FIELD		SUSTAINMENT							
			UNIT		DS	GS			DEPOT			
			C	O	F	H			D			
33	<b>SPECIALPURPOSE KITS - CONTINUED</b>	Front Armor	Inspect	0.2						A		
			Install		1.5					5,6,7,8		
			Replace		1.5					5,6,7,8		
		Rear Armor	Inspect	0.2								A
			Install		2.0					8		
			Replace		2.0					8		
		Roof Armor	Inspect	0.2								A
			Install		2.0					8		
			Replace		2.0					8		
		Side Armor Panels	Inspect	0.2								A
			Install		1.5					8		
			Replace		1.0					8		
		Wheel Housing	Inspect	0.2								A
			Install		2.0					5,6,7,8		
			Replace		2.0					5,6,7,8		
		Windshield Ballistic Glass	Inspect	0.2								A
			Service	0.2								B
			Install		2.0					2,6,8		
				Replace		2.0				2,6,8		

**MAINTENANCE ALLOCATION CHART (MAC) - CONTINUED**

**0033 00**

**Table 1. MAC for the Crew Protection Kit - Continued.**

(1) GROUP NUMBER	(2) COMPONENT/ ASSEMBLY	(3) MAINTENANCE FUNCTION	(4) MAINTENANCE LEVEL					(5) TOOLS AND EQUIPMENT REF CODE	(6) REMARKS CODE	
			FIELD		SUSTAINMENT					
			UNIT		DS	GS	DEPOT			
			C	O	F	H	D			

**Table 2. Tools and Test Equipment Requirements for the Crew Protection Kit.**

(1) TOOLS OR TEST EQUIPMENT REFERENCE CODE	(2) MAINTENANCE LEVEL	(3) NOMENCLATURE	(4) NATIONAL STOCK NUMBER (NSN)	(5) TOOL NUMBER (CAGEC)
1	O	Clamp, C: 2-1/2 In, 10 In. Size	5120-00-203-6432	5120-00-203-6432 (08292)
2	O	Dispenser, Sealant	5120-00-679-5655	101 (06798)
3	O	Drill Set, Twist: 33/64 to 3/4 Inch in 1/64 Inch Increments	5133-00-596-8088	B94.11M (05047)
4	O	Drill, Twist: 7/8 Inch		91456 (16568)
5	O	Link, Bearing (Lifting)	5120-01-451-1401	1387575 (11083)
6	O	Shop Equipment, Automotive Maintenance and Repair: Organizational Maintenance, Common No. 1, Less Power	4910-00-754-0654	SC 4910-95CLA74 (19204)
7	O	Sling, Nylon	2835-01-078-2081	4-8FTX2IN (91796)
8	O	Tool Kit, General Mechanic's: Automotive	5180-01-454-3787	12B470000 (59678)

**Table 3. Remarks for the Crew Protection Kit.**

(1) REMARKS CODE	(2) REMARKS
A	Refer to <i>Operator PMCS</i> (WP 0009 00).
B	Service by cleaning ballistic glass (WP 0010 00).

**END OF WORK PACKAGE**



---

**EXPENDABLE AND DURABLE ITEMS LIST**

---

**0034 00****SCOPE**

This work package lists expendable and durable items you will need to install, operate and maintain the Crew Protection Kit. This listing is for informational purposes only and is not authority to requisition the listed items. These items are authorized to you by CTA 50-970, *Expendable/Durable Items (Except Medical, Class V, Repair Parts, and Heraldic Items)*, or CTA 8-100, *Army Medical Department Expendable/Durable Items*.

**EXPLANATION OF COLUMNS**

1. **Column (1) - Item Number.** This number is assigned to the entry in the listing and is referenced in the narrative instructions to identify the item [e.g., Apply sealing compound (Item 6, WP 0034 00)].
2. **Column (2) - Level.** This column identifies the lowest level of maintenance that requires the listed item.
  - C - Operator/Crew
  - O - Unit Maintenance
3. **Column (3) - National Stock Number.** This is the National Stock Number assigned to the item which you can use to requisition it.
4. **Column (4) - Description, CAGEC, and Part Number.** This provides the other information you need to identify the item.
5. **Column (5) - Unit of Measure (U/M).** This column shows the physical measurement or count of an item, such as gallon, dozen, gross, etc.

## EXPENDABLE AND DURABLE ITEMS LIST - CONTINUED

0034 00

(1) ITEM NUMBER	(2) LEVEL	(3) NATIONAL STOCK NUMBER	(4) DESCRIPTION, CAGEC, AND PART NUMBER	(5) U/M
1	O	8040-01-250-3969	ADHESIVE: Thread (05972) 242 50 Milliliter Bottle	BT
2	C	6850-01-474-2318 6850-01-474-2320 6850-01-474-2321	CLEANING COMPOUND: Solvent, Type III (81349) MIL-PRF-680 1 Gallon Can 5 Gallon Can 55 Gallon Drum	CN CN DR
3	O	5350-00-584-4654	CLOTH, ABRASIVE (80204) ANSI B74.18 50 Sheet Package	PG
4	C	7930-00-282-9699 9140-00-286-5294 9140-00-286-5295 9140-00-286-5296	DETERGENT: General Purpose, Liquid (83421) 7930-00-282-9699 1 Gallon Can Bulk 5 Gallon Can 55 Gallon Drum	CN GL CN DR
5	C	9150-00-189-6727 9150-00-186-6668 9150-00-191-2772	OIL, LUBRICATING: OE/HDO-10 (81349) MIL-PRF-2104 1 Quart Can 5 Gallon Can 55 Gallon Drum	CN CN DR
6	C	7920-00-205-1711	RAG: Wiping (64067) A-A-431 50 Pound Bale	BL
7	O	8030-01-320-4710	SEALING COMPOUND: Urethane (52157) 051135-08609 10.5 Ounce Cartridge	CA
8	O		SIKA PRIMER 206 G+B (54786) 5510000034-00	TU
9	O	5975-01-379-4997	STRAP, TIEDOWN: Electrical Components (06383) PLT35-C-O Package of 100	PK

EXPENDABLE AND DURABLE ITEMS LIST - CONTINUED

0034 00

(1) ITEM NUMBER	(2) LEVEL	(3) NATIONAL STOCK NUMBER	(4) DESCRIPTION, CAGEC, AND PART NUMBER	(5) U/M
10	O		TAG, MARKER (64067) 9905-00-537-8954	
11	O	9905-00-537-8954  7510-00-473-9513	Bundle of 50  TAPE: Pressure Sensitive Adhesive (81349) MIL-T-23397  60 Yard Roll	BD    RL

END OF WORK PACKAGE



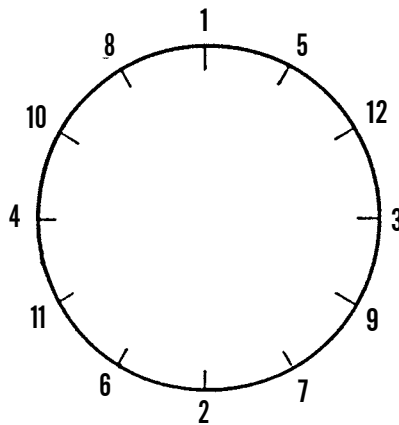
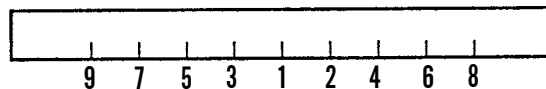


**SCOPE**

This work package lists standard torque values and provides general information for applying torque. Special torque values and tightening sequences are indicated in the maintenance procedures for applicable components.

**GENERAL**

1. Always use torque values listed in Tables 1 and 2 when a maintenance procedure does not give a specific torque value.
  - a. Table 1 provides torque limits for SAE standard fasteners.
  - b. Table 2 provides torque limits for metric fasteners.
2. Unless otherwise indicated, standard torque tolerance shall be  $\pm 10$  percent.
3. Torque values listed are based on clean, dry threads. Reduce torque by 10 percent when engine oil is used as a lubricant. Reduce torque by 20 percent if new plated capscrews are used.
4. If the maintenance procedures do not specify a tightening order, use the following guides:
  - a. Unless otherwise specified, lubricate threads of fasteners with clean oil (OE/HDO-10).
  - b. When tightening fasteners above 30 lb-ft (41 Nm), use the torque pattern but only tighten to 70 percent of final value (multiply final value by 0.7). Repeat pattern until final value is reached.
  - c. Tighten circular patterns using circular torque pattern and tighten straight patterns using straight torque pattern.

**CIRCULAR TORQUE PATTERN****STRAIGHT TORQUE PATTERN****CAUTION**

If replacement capscrews are of higher grade than originally supplied, use torque specifications for the original. This will prevent equipment damage due to overtightening.

Table 1. Torque Limits - SAE Standard Fasteners.

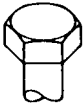


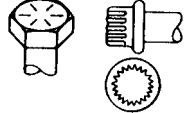
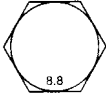
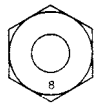
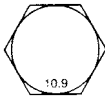

CURRENT USAGE	MUCH USED	MUCH USED	USED AT TIMES	USED AT TIMES
QUALITY OF MATERIAL	INDETERMINATE	MINIMUM COMMERCIAL	MEDIUM COMMERCIAL	BEST COMMERCIAL
SAE Grade Number	1 or 2	5	6 or 7	8
Cap Screw Head Markings				
Manufacturer's marks may vary				
These are all SAE Grade 5 (3 line)				
CAPSCREW BODY SIZE IN. - THREAD	TORQUE LB-FT (NM)	TORQUE LB-FT (NM)	TORQUE LB-FT (NM)	TORQUE LB-FT (NM)
1/4 20 28	5 (7) 6 (8)	8 (11) 10 (14)	10 (14)	12 (16) 14 (19)
5/16 18 24	11 (15) 13 (18)	17 (23) 19 (26)	19 (26)	24 (33) 27 (37)
3/8 16 24	18 (24) 20 (27)	31 (42) 35 (47)	34 (46)	44 (60) 49 (66)
7/16 14 20	28 (38) 30 (41)	49 (66) 55 (75)	55 (75)	70 (95) 78 (106)
1/2 13 20	39 (53) 41 (56)	75 (102) 85 (115)	85 (115)	105 (142) 120 (163)
9/16 12 18	51 (69) 55 (75)	110 (149) 120 (163)	120 (163)	155 (210) 170 (231)
5/8 11 18	83 (113) 95 (129)	150 (203) 170 (231)	167 (226)	210 (285) 240 (325)
3/4 10 16	105 (142) 115 (156)	270 (366) 295 (400)	280 (380)	375 (508) 420 (569)
7/8 9 14	160 (217) 175 (237)	395 (536) 435 (590)	440 (597)	605 (820) 675 (915)
1 8 14	235 (319) 250 (339)	590 (800) 660 (895)	660 (895)	910 (1234) 990 (1342)

Table 2. Torque Limits - Metric Fasteners.

TORQUE VALUES FOR METRIC THREAD FASTENERS WITH LUBRICATED* OR PLATED THREADS†				
Thread Diameter-Pitch				
	Class 8.8 Bolt	Class 8 Nut	Class 10.9 Bolt	Class 10 Nut
	Torque: lb-ft (Nm)		Torque: lb-ft (Nm)	
M6	5 (7)		7 (9)	
M8	12 (16)		17 (23)	
M8 x 1	13 (18)		18 (24)	
M10	24 (33)		34 (46)	
M10 x 1.25	27 (37)		38 (52)	
M12	42 (57)		60 (81)	
M12 x 1.5	43 (58)		62 (84)	
M14	66 (89)		95 (129)	
M14 x 1.5	72 (98)		103 (140)	
M16	103 (140)		148 (201)	
M16 x 1.5	110 (149)		157 (213)	
M18	147 (199)		203 (275)	
M18 x 1.5	165 (224)		229 (310)	
M20	208 (282)		288 (390)	
M20 x 1.5	213 (313)		320 (434)	
M22	283 (384)		392 (531)	
M22 x 1.5	315 (427)		431 (584)	
M24	360 (488)		498 (675)	
M24 x 2	392 (531)		542 (735)	
M27	527 (715)		729 (988)	
M27 x 2	569 (771)		788 (1068)	
M30	715 (969)		990 (1342)	
M30 x 2	792 (1074)		1,096 (1486)	

\* All plated and unplated fasteners should be coated with oil before installation.

† Use these torque values if either the bolt or nut is lubricated or plated (zinc-phosphate conversion-coated, cadmium-plated, or waxed).

END OF WORK PACKAGE







**EQUIPMENT INSTALLATION INSTRUCTIONS AND PARTS LIST  
FOR THE  
FREIGHTLINER M915-A3, M915-A2, AND M916-A1 VEHICLES  
CREW PROTECTION KITS**


Contract No. W56HZV-04-C-0259  
CDRL Items A001 and A002

Prepared for:

U.S. Army Tank – Automotive Command (TACOM)  
AMSTA-AQ-ATBC  
Warren, MI 48397-5000

Prepared by:

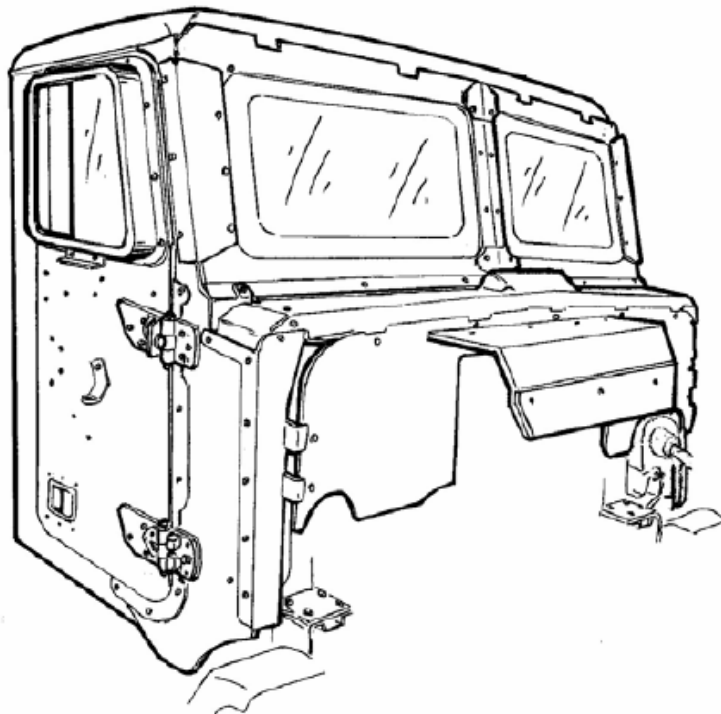
Simula Aerospace and Defense Group, Inc.  
A Subsidiary of Armor Holdings Aerospace and Defense Group  
7822 South 46th Street  
Phoenix, AZ 85044-5354  
(602) 643-SAFE

<b>REVISIONS</b>				
REV	CHANGED BY	DESCRIPTION	CM RELEASE	DATE
- (03)	C. Parsons	Initial Release Per ECO 487812 (No hardcopy ECO) Simula's initial release equals Rev. 03 because this document was previously a Plasan Sasa document.	J. Celis	25-May-05
A (04)	M. Seguin	Revised per ECO 488611	J. Celis	20-Sep-05
B (05)	M. Seguin	Revised Per ECO 489745	K. Rodriguez	26-Jan-06
C (06)	K. Rodriguez	Revised Per ECO 490257	L. Duguay	27-Feb-06
D (07)	C. Parsons	Revised Per ECO 490889. (Change authorization per TACOM Technical Approval of ECP490889 received 12-May-06)		18-May-06





**Installation Instructions  
for  
Freightliner M915-A3, M915-A2, and M916-A1  
Crew Protection Kits  
(Kit P/N 0257000000-00)**



**List of Updates (Effective Pages)**

Rev.	Date	Description	Page Number(s)
- (03)	24-May-05	Updated text and graphics on all pages of Plasan Sasa Manual 0257550622-00 – Initial Release of II113500-1	All Pages
A (04)	20-Sept-05	Updated per ECO 488611	1-3, TOC pages, 10-11, 19-20, 23-28, 30-43, 45-46, 48, 50-52, 54-60, 63, 67, 78-84, 87-90, 97, 108-136
B (05)	26-Jan-06	Updated per ECO 489745	1-3, 5, 8-9, 14, 18-20, 23-25, 30, 33-34, 37- 38, 40-41, 43, 46, 51, 55-56, 61, 68, 72, 75, 78, 81, 83-84, 88-90, 94, 96-97, 99, 101-102, 104, 107-115 Deleted, 116-117 Revised and Re-numbered, 118-120 Deleted, 121-129 Revised and Re-numbered, 130-131 Deleted 132-136 Revised and Re-numbered
C (06)		Updated per ECO 490257	4, 20, 37, 40
D (07)		Updated per ECO 490889	All Pages

## ***PREFACE***

### **Scope of This Manual**

This manual provides general guidelines on how to install the Crew Protection Kit, produced by Plasan LTD, on the Freightliner M915 and M916 model vehicles.

The manual is intended to be used by authorized and well-trained mechanics / production-line personnel.

The manual includes the following six chapters:

#### **Chapter 1: General Information**

This chapter summarizes the safety information presented in this manual, as well as a general overview and guidelines on how to install the Crew Protection Kit.

#### **Chapter 2: Cabin Preparations**

This chapter provides a list of the preparations and activities that should be performed on the Freightliner M915 cabin, prior to the Crew Protection Kit installation.

#### **Chapter 3: Kit Inventory**

This chapter provides a list of all items included in the Crew Protection Kit.

#### **Chapter 4: Kit Installation Checklist**

This chapter summarizes all the stages required for installing the Crew Protection Kit.

#### **Chapter 5: Installation Procedure**

This chapter provides sequential guidelines, accompanied with illustrations, on how to install each kit subassembly.

#### **Chapter 6: Fasteners**

This chapter assists in identification and selection of the required fasteners, used during the installation procedure.

#### **Chapter 7: M915-A2 and M916-A1 Specific Installation Steps**

This chapter provides additional and replacement instructions on how to install certain kit subassemblies for M915-A2 and M916-A1 vehicles.

## ***Table of Contents***

<b>PREFACE</b> .....	<b>3</b>
<b>1. GENERAL INFORMATION</b> .....	<b>9</b>
1.1 Introduction .....	9
1.2 Uncrating .....	9
1.3 List of Acronyms and Abbreviations.....	9
1.4 Special Tools and Equipment .....	9
1.5 Applicable Documents .....	9
1.6 Safety Precautions, Warnings, and Notes .....	9
1.7 Overview and General Installation Guidelines .....	10
<b>2. TEARDOWN AND VEHICLE PREPARATION</b> .....	<b>11</b>
2.1 Teardown .....	11
2.2 Preparation .....	11
<b>3. KIT INVENTORY</b> .....	<b>14</b>
3.1 Kit Inventory Ballistic Items .....	14
3.2 Non-Ballistic Items .....	16
3.3 Off-the-Shelf Items.....	18
3.4 M915 – A2 and M916 – A1 Adaptation Items (113502-1).....	18
3.5 Fasteners .....	19
<b>4. KIT INSTALLATION CHECKLIST</b> .....	<b>21</b>
<b>5. INSTALLATION PROCEDURE</b> .....	<b>23</b>
5.1 Cab Support Reinforcement Kit Installation .....	23
5.2 RH Wheel Housing Kit Installation .....	26
5.3 LH Wheel Housing Kit Installation.....	30
5.4 Floor Kit Installation .....	33
5.5 RH Kit Installation .....	36
5.6 LH Kit Installation.....	39
5.7 Backside Kit Installation .....	42
5.8 Roof Kit Installation .....	45
5.9 Windscreen Bars & Brackets Installation .....	51
5.10 Firewall Kit Installation .....	54
5.11 Emergency Exit Kit Installation .....	57
5.12 Front Cowl Kit Installation .....	61
5.13 RH Cowl (A-Pillar) Kit Installation .....	63
5.14 LH Cowl (A-Pillar) Kit Installation .....	67
5.15 Front Cover Kit Installation.....	71
5.16 Windscreen Kit Installation.....	74
5.17 Seats Installation .....	78
5.18 RH Armored Door Installation .....	80
5.19 RH Door Accessories Assembly .....	84
5.20 LH Armored Door Installation.....	87
5.21 LH Door Accessories Assembly.....	90
5.22 Insulation Installation .....	93
5.23 Kit Installation Completion .....	96

<b>6. FASTENERS .....</b>	<b>98</b>
6.1 Definitions of Maximal Initial Torque .....	98
6.2 Fastener Maps .....	99
<b>7. M915-A2 and M916-A1 Specific Instructions.....</b>	<b>108</b>
7.1 Preparation Work for Cab Support Installation (M916-A1 only) .....	108
7.2 Hood Spacer Installation (M915-A2 and M916-A1) .....	112
7.3 Installation of the LH Wheel Housing (M915-A2 and M916-A1) .....	113
7.4 Installation of the RH Wheel Housing (M915-A2 and M916-A1).....	117
7.5 Shift Tower Installation (M916-A1 only) .....	118
7.6 Shift Tower Installation (M915-A2 only) .....	120
7.7 Rear Wall Mounting Plate (M915-A2 and M916-A1).....	122
7.8 Relocate Engine Check Connector (M915-A2 and M916-A1) .....	124

## List of Figures

Figure 2-1. Cabin Preparations - Cutting the External Mirrors' Electrical Wiring .....	12
Figure 2-2. Cabin Preparations - Installing Cutting-Pattern #998 and Drilling One 8-mm (5/16") Hole .....	12
Figure 2-3. Cabin Preparations - Installing Cutting-Pattern #999 and Drilling One 8-mm (5/16") Hole .....	13
Figure 4-1. General View before Kit Installation .....	22
Figure 4-2. General View after Kit Installation .....	22
Figure 5-1. Supplemental Cab Support Kit Installation – Final View after Assembly Completion	23
Figure 5-2. Cab Support Reinforcement Kit Installation - Parts .....	23
Figure 5-3. Supplemental Cab Support Reinforcement Kit Installation – Rubber Bumper (#179) Removal / Installation .....	25
Figure 5-4. Installing the RH Wheel Housing – Final View after Assembly Completion .....	26
Figure 5-5. Installing the RH Wheel Housing - Parts .....	26
Figure 5-6. Installing the RH Wheel Housing – Placing the RH Wheel Housing Support Arm ...	28
Figure 5-6a. Installing the RH Wheel Housing – RH Wheel Housing Fasteners .....	29
Figure 5-7. Installing the LH Wheel Housing – Final View after Assembly Completion .....	30
Figure 5-8. Installing the LH Wheel Housing - Parts.....	30
Figure 5-9. Installing the LH Wheel Housing – Placing the LH Wheel Housing Support Arm ...	32
Figure 5-9a. Installing the LH Wheel Housing – LH Wheel Housing Fasteners .....	32
Figure 5-10. Floor Kit Installation - Final View .....	33
Figure 5-11. Floor Kit Installation – Parts.....	33
Figure 5-12. LH (Driver's) Floor Kit Installation (1 of 4) .....	34
Figure 5-13. RH (Passenger's) Floor Kit Installation (2 of 4) .....	34
Figure 5-14. Floor Kit Installation (3 of 4).....	35
Figure 5-15. Floor Kit Installation (4 of 4).....	35
Figure 5-16. RH Kit Installation - Final View .....	36
Figure 5-17. RH Kit Installation – Parts.....	36
Figure 5-18. RH Kit Installation (1 of 3).....	38
Figure 5-19. RH Kit Installation (2 of 3).....	38
Figure 5-20. RH Kit Installation (3 of 3).....	38
Figure 5-21. LH Kit Installation - Final View.....	39
Figure 5-22. LH Kit Installation – Parts .....	39
Figure 5-23. LH Kit Installation (1 of 3) .....	40
Figure 5-24. LH Kit Installation (2 of 3) .....	40
Figure 5-25. LH Kit Installation (3 of 3) .....	41
Figure 5-26. Backside Kit Installation - Final View.....	42

Figure 5-27. Backside Kit Installation – Parts .....	42
Figure 5-28. Backside Kit Installation (1 of 3) .....	44
Figure 5-29. Backside Kit Installation (2 of 3) .....	44
Figure 5-30. Backside Kit Installation (3 of 3) .....	44
Figure 5-31. Roof Kit Installation - Final View .....	45
Figure 5-32. Roof Kit Installation – Parts .....	45
Figure 5-33. Roof Kit Installation (1 of 10) .....	47
Figure 5-34. Roof Kit Installation (2 of 10) .....	47
Figure 5-35. Roof Kit Installation (3 of 10) .....	48
Figure 5-36. Roof Kit Installation (4 of 10) .....	48
Figure 5-37. Roof Kit Installation (5 of 10) .....	49
Figure 5-38. Roof Kit Installation (6 of 10) .....	49
Figure 5-39. Roof Kit Installation (7 of 10) .....	49
Figure 5-40. Roof Kit Installation (8 of 10) .....	49
Figure 5-41. Roof Kit Installation (9 of 10) .....	50
Figure 5-42. Roof Kit Installation (10 of 10) .....	50
Figure 5-43. Windscreen Bars and Brackets Installation - Final View .....	51
Figure 5-44. Windscreen Bars and Brackets Installation - Parts .....	51
Figure 5-45. Windscreen Bars and Brackets Installation - Right Side (1 of 4) .....	52
Figure 5-46. Windscreen Bars and Brackets Installation - Right Side (2 of 4) .....	52
Figure 5-47. Windscreen Bars and Brackets Installation - Left Side (3 of 4) .....	53
Figure 5-48. Windscreen Bars and Brackets Installation – Left Side (4 of 4) .....	53
Figure 5-49. Firewall Kit Installation - Final View .....	54
Figure 5-50. Firewall Kit Installation – Parts .....	54
Figure 5-51. Firewall Kit Installation (1 of 4) .....	55
Figure 5-52. Firewall Kit Installation (2 of 4) .....	55
Figure 5-53. Firewall Kit Installation (3 of 4) .....	56
Figure 5-54. Firewall Kit Installation (4 of 4) .....	56
Figure 5-55. Emergency Exit Kit Installation - Final View .....	57
Figure 5-56. Emergency Exit Kit Installation – Parts .....	57
Figure 5-57. Emergency Exit Kit Installation (1 of 4) .....	59
Figure 5-58a. Emergency Exit Kit Installation (2 of 4) .....	59
Figure 5-58b. Emergency Exit Kit Installation - ECM mounting (3 of 4) .....	60
Figure 5-59. Emergency Exit Kit Installation (4 of 5) .....	60
Figure 5-60. Front Cowl Kit Installation - Final View .....	61
Figure 5-61. Front Cowl Kit Installation – Parts .....	61
Figure 5-62. Front Cowl Kit Installation (1 of 1) .....	62
Figure 5-63. RH Cowl Kit Installation - Final View .....	63
Figure 5-64. RH Cowl Kit Installation – Parts .....	63
Figure 5-65a. RH Cowl Kit Installation – Door Step Preparation (1 of 3) .....	65
Figure 5-65b. RH Cowl Kit Installation (2 of 3) .....	66
Figure 5-66. RH Cowl Kit Installation (3 of 3) .....	66
Figure 5-67. LH Cowl Kit Installation - Final View .....	67
Figure 5-68. LH Cowl Kit Installation – Parts .....	67
Figure 5-69a. LH Cowl Kit Installation – Door Step Preparation (1 of 3) .....	69
Figure 5-69b. LH Cowl Kit Installation (2 of 3) .....	70
Figure 5-70. LH Cowl Kit Installation (3 of 3) .....	70
Figure 5-71. Front Cover Kit Installation - Final View .....	71
Figure 5-72. Front Cover Kit Installation – Parts .....	71
Figure 5-73. Front Cover Kit Installation (1 of 5) .....	72
Figure 5-74. Front Cover Kit Installation (2 of 5) .....	72

Figure 5-75. Front Cover Kit Installation (3 of 5).....	73
Figure 5-76. Front Cover Kit Installation (4 of 5).....	73
Figure 5-77. Front Cover Kit Installation (5 of 5).....	73
Figure 5-78. Windscreen Kit Installation - Final View .....	74
Figure 5-79. Windscreen Kit Installation – Parts.....	74
Figure 5-80. Windscreen Kit Installation (1 of 7).....	76
Figure 5-81. Windscreen Kit Installation (2 of 7).....	76
Figure 5-82. Windscreen Kit Installation (3 of 7).....	76
Figure 5-83. Windscreen Kit Installation (4 of 7).....	76
Figure 5-84. Windscreen Kit Installation - Right Side (5 of 7).....	77
Figure 5-85. Windscreen Kit Installation – Left Side (6 of 7).....	77
Figure 5-86. Windscreen Kit Installation (7 of 7).....	77
Figure 5-87. Seats Installation - Final View .....	78
Figure 5-88. Seats Installation – Parts.....	78
Figure 5-89. Seats Installation - Seats Base Installation (1 of 1) .....	79
Figure 5-90. RH Armored Door Installation - Final View.....	80
Figure 5-91. RH Armored Door Installation - Parts.....	80
Figure 5-92. RH Armored Door Installation (1 of 4) .....	82
Figure 5-93. RH Armored Door Installation (2 of 4) .....	82
Figure 5-94. RH Armored Door Installation (3 of 4) - Lower Hinge.....	83
Figure 5-95. RH Armored Door Installation (4 of 4) - Upper Hinge.....	83
Figure 5-96. RH Door Accessories Assembly - Parts Removed from the Original Door .....	85
Figure 5-97. RH Door Accessories Assembly (1 of 6) .....	85
Figure 5-98. RH Door Accessories Assembly (2 of 6) .....	85
Figure 5-99. RH Door Accessories Assembly (3 of 6) .....	86
Figure 5-100. RH Door Accessories Assembly (4 of 6) .....	86
Figure 5-101. RH Door Accessories Assembly (5 of 6) .....	86
Figure 5-102. RH Door Accessories Assembly (6 of 6) .....	86
Figure 5-103. LH Armored Door Installation - Final View .....	87
Figure 5-104. LH Armored Door Installation – Part.....	87
Figure 5-105. LH Armored Door Installation (1 of 4).....	88
Figure 5-106. LH Armored Door Installation (2 of 4).....	88
Figure 5-107. LH Armored Door Installation (3 of 4) - Lower Hinge .....	89
Figure 5-108. LH Armored Door Installation (4 of 4) - Upper Hinge .....	89
Figure 5-109. LH Door Accessories Assembly - Parts Removed from the Original Door.....	91
Figure 5-110. LH Door Accessories Assembly (1 of 6).....	91
Figure 5-111. LH Door Accessories Assembly (2 of 6).....	91
Figure 5-112. LH Door Accessories Assembly (3 of 6).....	92
Figure 5-113. LH Door Accessories Assembly (4 of 6).....	92
Figure 5-114. LH Door Accessories Assembly (5 of 6).....	92
Figure 5-115. LH Door Accessories Assembly (6 of 6).....	92
Figure 5-116. Insulators Installation - Final View .....	93
Figure 5-117. Insulators Installation (1 of 7) - Location of RH Side Wall Internal Insulation.....	93
Figure 5-118. Insulators Installation (2 of 7) - LH Side Wall Insulation .....	94
Figure 5-119. Insulators Installation (3 of 7) - Backside Insulation .....	94
Figure 5-120. Insulators Installation (4 of 7) - Roof Insulation .....	95
Figure 5-121. Insulators Installation (5 of 7) - RH Corner Insulation.....	95
Figure 5-122. Insulators Installation (6 of 7) - LH Corner Insulation .....	95
Figure 5-123. Insulators Installation (7 of 7) - RH Front Insulation .....	95
Figure 5-124. Reinstallation of Interior Components .....	97
Figure 6-1. Fasteners Map - Cab Support Reinforcement.....	99
Figure 6-2. Fasteners Map - RH and LH Wheels Housing .....	100

Figure 6-3. Fasteners Map - Floor and Firewall.....	101
Figure 6-4. Fasteners Map - RH and LH sides .....	102
Figure 6-5. Fasteners Map – Backside .....	103
Figure 6-6. Fasteners Map – Roof .....	104
Figure 6-7. Fasteners Map - Windscreen and Front Cover (1 of 2) .....	105
Figure 6-8. Fasteners Map - Windscreen and Front Cover (2 of 2) .....	106
Figure 6-9. Fasteners Map - RH and LH Doors .....	107
Figure 7-1. Elbow Adjustment.....	110
Figure 7-2. Hose Wrap Location .....	110
Figure 7-3. Hose Wrap Location .....	111
Figure 7-4. Strap Installation.....	111
Figure 7-5. Hood Spacer.....	112
Figure 7-6. #967 Installation .....	114
Figure 7-7. Wheel Housing Support Arm .....	114
Figure 7-8. Wheel Housing .....	116
Figure 7-9. Hose Wrap Location .....	116
Figure 7-10. Shift Tower Installation (M915-A2) .....	119
Figure 7-11. Shift Tower Installation (M916-A1) .....	121
Figure 7-12. Mounting Plate Installation .....	123
Figure 7-13. Engine Check Bracket Install.....	124

## ***List of Tables***

Table 3-1. Kit Inventory - Ballistic Items.....	14
Table 3-2. Kit Inventory - Non-Ballistic Items.....	16
Table 3-3. Kit Inventory - Off-the-Shelf Items .....	18
Table 3-4. Kit Inventory - M915-A2 and M916-A1 Adaptation Items (113502-1).....	18
Table 3-5. Kit Inventory - Fasteners List.....	19
Table 4-1. Kit Installation Checklist.....	21
Table 6-1. Definitions of Maximal Initial Torque.....	98



## 1. GENERAL INFORMATION

### 1.1 INTRODUCTION

This document provides the Installation Instructions for the Crew Protection Kit for the M915-A3, M915-A2, and M916-A1 vehicles. This kit is composed of various armor panels that can be easily attached and detached from the vehicle and stored when not required.

This kit (113500-1) provides the M915-A3, M915-A2, and M916-A1 vehicles with improved protection against mine blasts, improvised explosive devices (IEDs), light artillery fragments, and small-arms fire. The M915-A2 and the M916-A1 require the Adaptation Kit, 113502-1.

### 1.2 UNCRATING

Crating may vary depending on the point of origin. Typically, each crate is contained in multiple containers. These containers provide the kit contents with protection and security when they are not installed on the vehicle. Note: The crates are not designed for outside storage. Several of the components within the kit require the at least two people to safely lift. Some of the components within the kit require the use of lifting equipment (hoist, forklift, etc.)

### 1.3 LIST OF ACRONYMS AND ABBREVIATIONS

LH: Left Hand  
P/N: Part Number  
RH: Right Hand

### 1.4 SPECIAL TOOLS AND EQUIPMENT


Special Tools: None.  
Special Equipment: Forklift or similar.


### 1.5 APPLICABLE DOCUMENTS



None applicable

### 1.6 SAFETY PRECAUTIONS, WARNINGS AND NOTES

The following notes included in this manual to provide a short, concise and readily visible emphasis. Explanations of each are provided in the examples provided below. Always observe standard safety precautions during installation, operation, and maintenance of this product.

	<b>WARNING</b> An operating procedure, practice, and so forth, which, if not correctly followed, could result in personnel injury or loss of life.
---	---

	<b>CAUTION</b> An operating procedure, practice, and so forth, which if not strictly observed, could result in personnel injury or damage to, or destruction of, equipment.
---	--

	<b>IMPORTANT</b> An operating procedure, practice, and so forth, that is essential to highlight.
	<b>LIFT HAZARD</b> Either two personnel or lifting devices are required. Proper lifting and securing devices are always required. Failure to comply could result in personnel injury or damage to, or destruction of, equipment.

## 1.7 OVERVIEW AND GENERAL INSTALLATION GUIDELINES

The Crew Protection Kit is an add-on system designed for use on the M915-A3, M915-A2, and M916-A1 vehicles. These Installation Instructions were originally written specifically for the M915-A3 application, and additional instructions were added in Revision A to adapt it for the M915-A2 and M916-A1 models.

In order to facilitate easy assembly, there are certain steps that must be executed properly and in the right order:

1. Prepare the cabin (see Chapter 2: Cabin Preparations). For the M915-A2 models, certain steps of the Air Conditioner Kit installation should be performed before the installation of the armor.
2. Unpack the kit subassemblies according to the order of installation. The installation sequence should follow the sequence as presented in this manual.
3. Locate / identify all the kit subassembly parts before installation.
4. Use the provided figures to identify the proper screws for each assembly. In addition, fastener maps are provided in Section 6.
5. Do not tighten the fasteners until all pieces have been fitted. This allows the pieces to be shifted for alignment. For the M915-A2 models, complete the installation of the Air Conditioner Kit prior to applying locking compound and tightening all fasteners.
6. Upon completion of the installation of all components:
  - a) Spread locking compound on all screws (LOCTITE #243, Blue).
  - b) Install all remaining screws.
  - c) Tighten all screws. **Check that no released screws are left un-tightened.**
7. Some parts (like the doors and windscreen) are heavy, and require lifting devices. **Use proper lifting and securing devices to avoid injuries and damage to equipment!**
8. Use the provided telescopic stand to secure the roof parts during assembly.
9. The windscreen and front parts are glued with Sikaflex. Read and use the manufacturer instructions during assembly.
10. Spread Sikaflex on the adjoining side of all front parts and on screws before assembly, to avoid water and moisture from entering the cabin.

## 2. TEARDOWN AND VEHICLE PREPARATION

This chapter provides a list of the preparations and activities that should be performed on the M915-A3, M915-A2, and M916-A1 cabin, prior to the Crew Protection Kit installation.

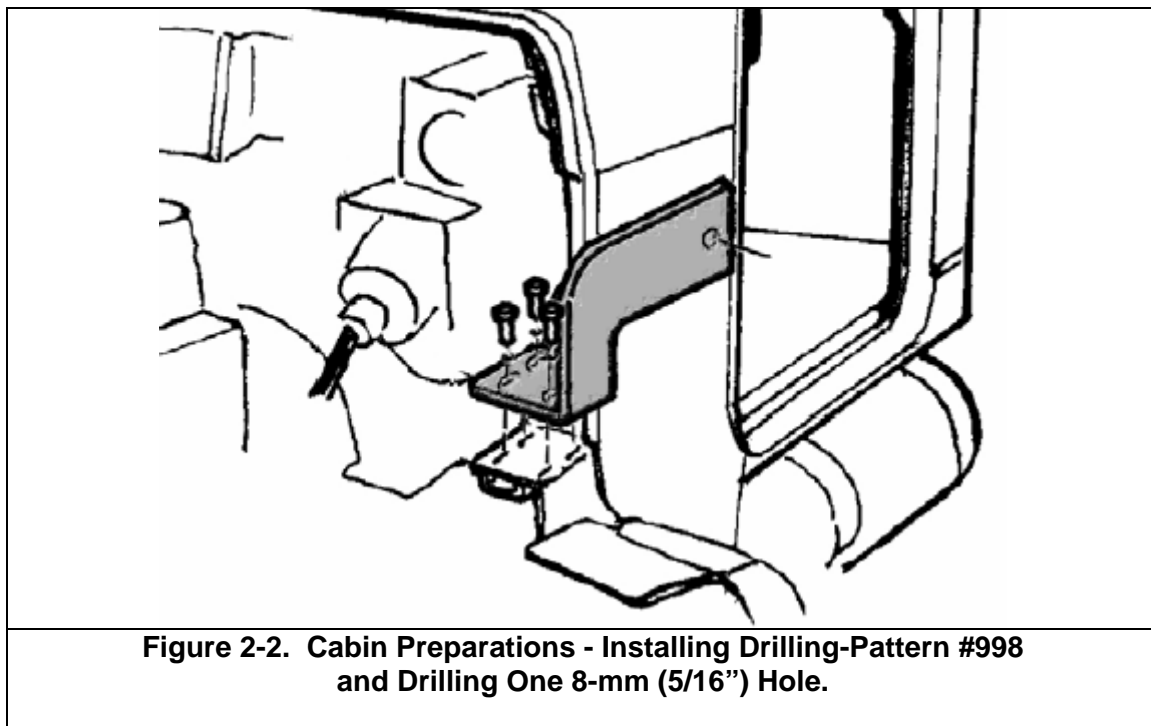
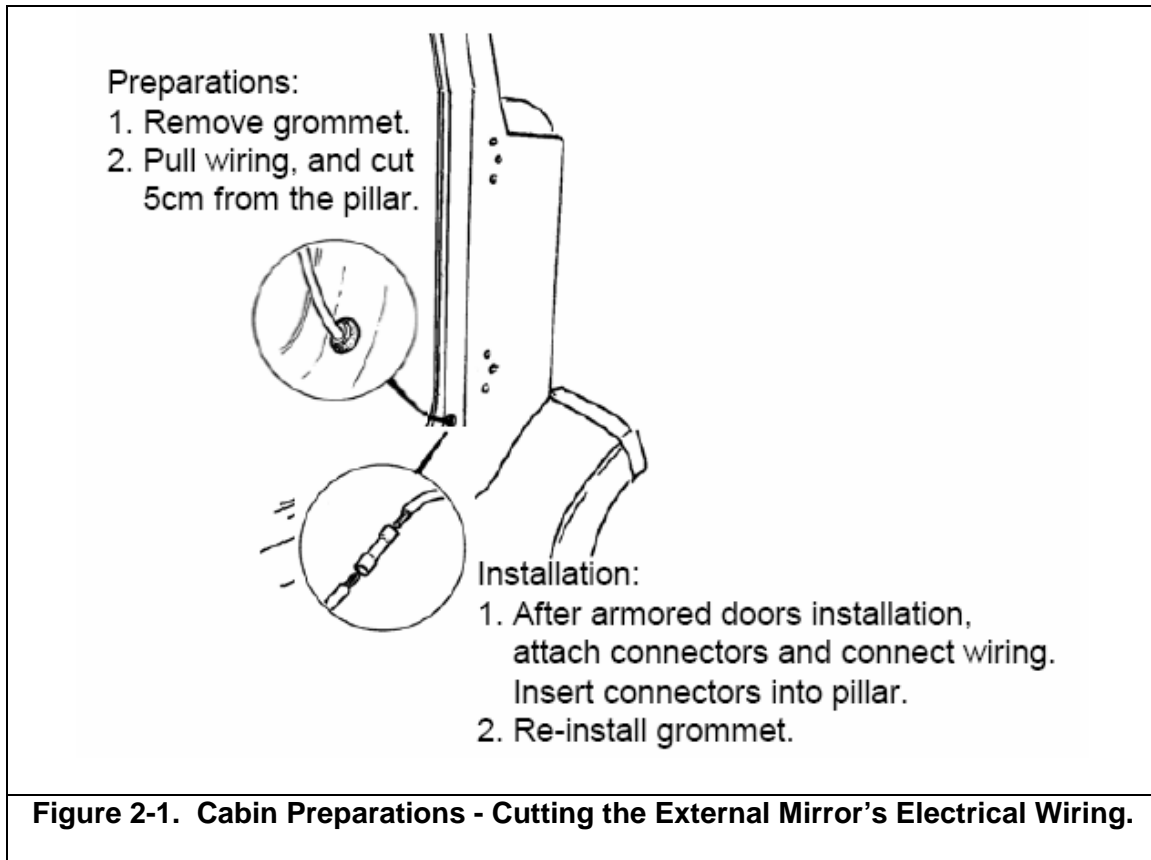
### 2.1 TEARDOWN

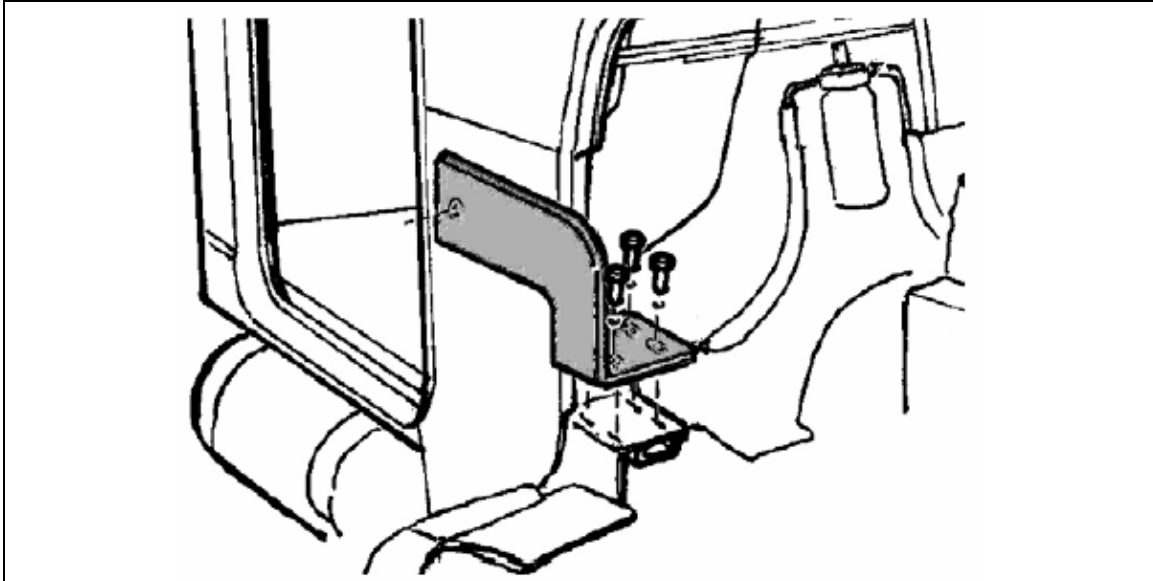
1. Disconnect the battery.
2. Relieve air pressure from the vehicle's air system.
3. Perform the following preparations (keep the removed accessories, as some of the components will be used during reassembly):
  - a) Cut the external mirrors' electrical wiring (see Figure 2-1).
  - b) Remove the original doors. (The complete door including all accessories and parts. Do not cut the door stop straps.)
  - c) Remove the seat belts.
  - d) Remove the seats.
  - e) Remove the internal accessories [handles, overhead cabin (dome) lights, sun visors (complete assembly), and anything else attached to the cabin walls and roof]. Note: The overhead console and trim panels need not be removed.
  - f) Remove the shift selector bracket (shift tower).
  - g) Remove the plastic cover of the central windscreen support.
  - h) Remove the windshield wiper arms.
  - i) Remove the original windscreen.
  - j) Remove the hood bumpers (2).
  - k) Remove the hood plastic bumpers (6 total).
  - l) Remove the hood locks.
  - m) Remove the door latch striker posts from the B pillar.
  - n) Remove the rear window guard screen.

### 2.2 PREPARATION

**Note:** For M915 models with an Air Conditioner perform the following steps from Manual RD-2-4617-0:

- Compressor Mounting, entire section (RD-9-10061-0)
  - Condenser Mounting, entire section, starting on Page 2
  - Receiver / Dryer Mounting, entire section, starting on Page 3
  - Hose Routing, Steps 1 through 16, starting on Page 6
  - Electrical Connections, Steps 1 through 15, starting on Page 11.
1. Install drilling-pattern #998 and drill one hole as follows:
    - a) Install drilling-pattern #998 (see Figure 2-2) on the cowl bumper brackets as shown using the original bumper installation fasteners.
    - b) Drill one 8-mm (5/16") hole, and remove the drilling-pattern.
    - c) Drill a 30-mm (1-1/8") hole using the 8-mm hole as the drilling reference.
    - d) Remove the drill pattern. Retain the fasteners for later use.
  2. Install drilling pattern #999 and drill one hole as follows:
    - a) Install drilling pattern #999 (see Figure 2-3) on the cowl bumper brackets as shown using the original bumper installation fasteners.
    - b) Drill one 8-mm hole, and remove the drilling-pattern.
    - c) Drill a 30-mm hole using the 8-mm hole as the drilling reference.
    - d) Remove the drill pattern. Retain the fasteners for later use.





**Figure 2-3. Cabin Preparations - Installing Drilling-Pattern #999 and Drilling One 8-mm (5/16") Hole.**

### 3. Kit Inventory

This chapter provides a list of all items included in the Crew Protection Kit.

#### 3.1 Ballistic Items

The ballistic items in the Crew Protection Kit are listed in Table 3-1.

**Table 3-1. Kit Inventory - Ballistic Items**

Part No.	Alternate Part No.	Item Description	Find No. in Figures	Qty
0257040001-00		Door RH Assy	#001	1
0257040002-00		Door LH Assy	#002	1
0257020003-00	0257020063-00	Front Window RH Assy	#003	1
0257020004-00	0257020064-00	Front Window LH Assy	#004	1
0257060005-00	0257060065-00	Rear Window Assy	#005	1
0257970006-00		Wheel Deflector Internal RH Assy	#006	1
0257970007-00		Wheel Deflector Internal LH Assy	#007	1
5340000106-00		Emergency Exit Handle	#106	2
0257062205-00	0257062305-00	RH Rear Panel	#205	1
0257062206-00	0257062306-00	LH Rear Panel	#206	1
0257032213-00		RH Side Panel	#213	1
0257032214-00		LH Side Panel	#214	1
0257122227-00		Floor LH Toeboard	#227	1
0257032250-00	0257037350-00	LH A -Pillar Internal	#250	1
0257032251-00	0257037351-00	RH A -Pillar Internal	#251	1
0257032253-00	0257037353-00	RH A -Pillar Top Internal	#253	1
0257032254-00	0257037354-00	LH A -Pillar Top Internal	#254	1
0257032255-00	0257037155-00	LH A -Pillar External	#255	1
0257032256-00	0257037156-00	RH A -Pillar External	#256	1
0257022262-00	0257027362-00	Firewall External	#262	1
0257022265-00	0257027365-00	Internal Firewall Center	#265	1
0257022266-00	0257027366-00	Internal Firewall Service Hatch	#266	1
0257022268-00	0257027368-00	Internal Firewall RH 2	#268	1
0257017703-00		Rear Roof Overlap	#703	1
0257017704-00		Central Windscreen Overlap Top	#704	1
0257027706-00		Air Filter	#706	1
0257017709-00		Upper Head Peace Overlap	#709	1
0257127725-00		Overlap Driver	#725	1
0257027763-00		Overlap For Air Filter	#763	1
0257027780-00		RH Windscreen Surround Overlap	#780	1
0257027781-00		LH Windscreen Surround Overlap	#781	1
0257027782-00		Central Windscreen Overlap Middle	#782	1
0257047785-00		Overlap Door Lock	#785	2
0257027793-00		Interior Firewall RH of Central Wall	#793	1

Part No.	Alternate Part No.	Item Description	Find No. in Figures	Qty
0257010801-00		LH/RH Rear Roof Corner	#801	2
0257010802-00	0257010864-00	RH Rear Roof Overlap	#802	1
0257010803-00	0257010865-00	LH Rear Roof Overlap	#803	1
0257010804-00		Front Roof Panel	#804	1
0257120805-00		Passenger Floor Seat Base	#805	1
0257020806-00		Cover, Firewall	#806	1
0257020810-00		Cowl Armor External Central	#810	1
0257020811-00		RH Internal Firewall	#811	1
0257020813-00		Interior Firewall Driver Side	#813	1
0257020814-00		Interior A Pillar Bottom	#814	1
0257120815-00		Middle Floor	#815	1
0257120816-00		Driver Floor Seat Base	#816	1
0257010817-00		LH Rear Roof	#817	1
0257010818-00		RH Rear Roof	#818	1
0257030819-00		LH A -Pillar External Overlap	#819	1
0257030820-00		RH A -Pillar External Overlap	#820	1
0257030826-00		LH Rear B Pillar	#826	1
0257030827-00		RH Rear B Pillar	#827	1
0257010828-00	0257010866-00	RH Backside Roof Bar	#828	1
0257010829-00	0257010867-00	LH Backside Roof Bar	#829	1
0257020830-00		Cowl Armor External Corner Left	#830	1
0257020831-00		Cowl Armor External Corner Right	#831	1
0257020832-00		Cowl Armor External Side Left	#832	1
0257020833-00		Cowl Armor External Side Right	#833	1
0257010842-00		Rear RH Corner External Fair Wall	#842	1
0257010843-00		Rear LH Corner External Fair Wall	#843	1
0257060844-00		LH Rear Panel	#844	1
0257030845-00		LH A-Pillar Overlap 1 External	#845	1
0257030846-00		RH A-Pillar Overlap 1 External	#846	1
0257120849-00		RH Floor Passenger	#849	1
0257120850-00		LH Floor	#850	1

### 3.2 Non-Ballistic Items

The non-ballistic items in the Crew Protection Kit are listed in Table 3-2.

**Table 3-2. Kit Inventory - Non-Ballistic Items**

Part No.	Alternate Part No.	Item Description	Find No. in Figures	Qty
0257550008-00		Support, Roof , Assy	#008	1
0257040009-00		Stopper, Assy, Door	#009	2
0257970010-00		Cab support Assy	#010	1
0257010012-00		Opposite to a Lock Set (Striker)	#012	2
0257950601-00		Isolation Rear Wall RH	#601	1
0257950602-00		Isolation Rear Wall LH	#602	1
0257950603-00		Isolation Rear B Pillar	#603	2
0257950604-00		Isolation Rear Roof LH	#604	1
0257950605-00		Isolation Rear Roof RH	#605	1
0257950606-00		Isolation Rear Roof Overlap 1	#606	2
0257950607-00		Isolation Rear Roof Overlap 2	#607	2
0257950608-00		Isolation LH A -Pillar Internal 1	#608	1
0257950609-00		Isolation LH A -Pillar Internal 2	#609	1
0257950610-00		Isolation RH A -Pillar Internal	#610	1
0257950611-00		Isolation Left Rear Roof	#611	1
0257950612-00		Isolation Right Rear Roof	#612	1
0257950613-00		Isolation Front Roof 1	#613	1
0 257950614-00		Isolation Front Roof 2	#614	1
0257950615-00		Isolation Side Panel LH	#615	1
0257950616-00		Isolation Side Panel RH	#616	1
0257950617-00		Isolation RH Internal Firewall	#617	1
0257950618-00		Isolation Rear Roof Corner	#618	2
0257970624-00		Polyurethane Spacer	#624	2
0257020625-00		Plate For Sealer Front Window	#625	1
0257970658-00		Support, RH	#658	1
0257970659-00		Support, LH	#659	1
0257040914-00		Spacer for Hinge Door Internal	#914	4
0257040915-00		Spacer for Hinge Door EXT 16	#915	4
0257040916-00		Spacer for Hinge Door EXT 2	#916	8
0257040922-00		LH Upper Hinge Assy	#922	1
0257040923-00		RH Upper Hinge Assy	#923	1
0257040924-00		LH Lower Hinge Assy	#924	1
0257040925-00		RH Lower Hinge Assy	#925	1
0257040938-00		Connection Bar-Door Handle	#938	2
0257040949-00		Door Stopper Welding	#949	2
0257030951-00		Spacer For RH A -Pillar Top Internal	#951	1



Part No.	Alternate Part No.	Item Description	Find No. in Figures	Qty
0257030952-00		Bracket Side Panel RH	#952	1
0257030953-00		Bracket Side Panel LH	#953	1
0257030954-00		Spacer For LH A -Pillar Top Internal	#954	1
0257030955-00		Spacer for Hinge Side	#955	4
0257020956-00		Bracket, frame front window	#956	1
0257020957-00		Bracket, frame front window	#957	1
0257020958-00		Bracket, Frame Front Window To Side LH	#958	1
0257020959-00		Bracket, Frame Front Window To Side RH	#959	1
0257030960-00		Spacer External Side	#960	2
0257030962-00		Lock Bracket	#962	1
0257030963-00		Lock Bracket	#963	1
0257030964-00		Contra For Lock Side	#964	2
0257030965-00		Bracket Engine Cover LH	#965	1
0257030966-00		Bracket Engine Cover RH	#966	1
0257060968-00		Frame, Rear Window	#968	1
0257020969-00		Bracket, Air Filter Armor	#969	4
0257970970-00		Support, Wheel Housing	#970	1
0257970970-00		Support, Wheel Housing	#971	1
0257020972-00		Bracket Driver Floor to Firewall Internal	#972	1
0257120973-00		Bracket Driver Floor to Side Internal	#973	1
0257120974-00		Bracket Driver Floor to Middle Floor	#974	1
0257120975-00		Bracket Front Floor to Middle Floor	#975	1
0257120976-00		Bracket, Center Firewall to RH Firewall	#976	1
0257060980-00		Connection Middle Floor to Back Wall 1	#980	1
0257020981-00		Connection Middle Floor to Back Wall 2	#981	1
0257020982-00		Connection Firewall to Internal Side RH	#982	1
0257120983-00		Connection RH Floor to Back	#983	1
0257120984-00		Connection LH Floor to Back	#984	1
0257120985-00		Connection RH Floor to Firewall Internal	#985	1
0257120986-00		Connection Middle Floor to RH Floor	#986	1
0257120987-00		Connection Middle Floor to Back Wall 2	#987	1
0257020988-00		Connection Internal Firewall Driver Side	#988	1
0257020989-00		Support windscreen	#989	1
0257020990-00		Support windscreen	#990	1
0257030991-00		Seat Belt and Side Bushing1	#991	2
0257030992-00		Seat Belt and Side Bushing2	#992	2
0257120993-00		Rear Window Stopper	#993	2
0257030998-00		RH Drilling Pattern	#998	1
0257030999-00		LH Drilling Pattern	#999	1

### 3.3 Off-the-Shelf Items

The off-the-shelf items in the Crew Protection Kit are listed in Table 3-3.

**Table 3-3. Kit Inventory - Off-the-Shelf Items**

Part No.	Alternate Part No.	Item Description	Find No. in Figures	Qty
5510000019-00	Sikaflex-296	Sikaflex-265		600 ml
5510000034-00	206-HL	SIKA Primer 206 G+P		2
5340000106-00	190810263	ZETA		2
5540000028-00	MF-18	Rubber Profile MF-18	#028	0.8 m
5340000044-00	86805T83	Ring		2
5110000036-00	4959	Two-Sided Tape 3/4" 4959		1 m
5520000029-00	-	Primer for Two-Sided Tape 3/4" 4959		1
5340000208-00	-	Brush		4
5350000002-00	722K13	Crimp Connector for electric wires		9
5340000027-00	7130K12	Clamp, Plastic		6
5340000028-00	7566K25	Holding		6
5510000037-00	T70	Anaerobic Adhesive Glue		1
5340000209-00	-	Caulking Gun		1

### 3.4 M915-A2 and M916-A1 Adaptation Items (113502-1)

The M915-A2 and M916-A1 Adaptation Items are listed in Table 3-4.

**Table 3-4. Kit Inventory - Off-the-Shelf Items**

Part No.	Alternate Part No.	Item Description	Find No. in Figures	Qty
113507-1		Plate, Mounting	#507	1
113508-1		Strap, Hose Support	#508	1
113509-1		Adapter, Shift Tower	#509	1
0257970642-00	113512-1	Spacer, Hood	#642	2
0257970640-00	113513-1	Spacer, Wheel Zone Deflector	#640	4
0257970643-00	113513-1	Spacer, Wheel Zone Deflector	#643	4
G81900-0012		Wrap, Hose	#0012	1.6 ft
0093200		Wrap, Hose	#200	3.0 ft
1-1/2 x 3 57A24-R		Snagging (Grinding) Wheel		1
113511-1		Adapter, Shift Tower	#511	1

### 3.5 Fasteners

The fasteners used in the Crew Protection Kit are listed in Table 3-5.

**Table 3-5. Fasteners List**

No.	Type	Head	Part No.	Size
1	NC Steel Bolt	Button Head Allen Bolt	5310000386-00	M5 x 10
2	NC Steel Bolt	HEX	5310000360-00	5/16" x 3/4"
3	NC Steel Bolt	HEX	5310000361-00	5/16" x 1"
4	NC Steel Bolt	HEX	5310000327-00	5/16" x 1-1/4"
5	NC Steel Bolt	Button Head Allen Bolt	5310000380-00	5/16" x 1-1/4"
6	NC Steel Bolt	HEX	5310000362-00	5/16" x 1-1/2"
7	Galvanized Star Washer		5320000105-00	3/4"
8	NC Steel Bolt	HEX	5310000363-00	5/16" x 1-3/4"
9	NC Steel Bolt	HEX	5310000368-00	5/16" x 2"
10	NC Steel Bolt	HEX	5310000328-00	5/16" x 2-1/2"
11	NC Shoulder Nut		5330000054-00	3/4"
12	NC Steel Bolt	Screw Countersunk	5310000350-00	5/16" x 1"
13	NC Steel Bolt	HEX	5310000385-00	3/8" x 3-1/2"
14	NC Steel Bolt	HEX	5310000260-00	3/8" x 1-3/4"
15	NC Steel Bolt	Screw Countersunk	5310000370-00	1/4" x 3/4"
16	NC Steel Bolt	Button Head Allen Bolt	5310000379-00	1/4" x 3/4"
17	NC Steel Bolt	HEX	5310000355-00	1/4" x 1-1/4"
18	NF Steel Bolt	HEX	5310000366-00	7/16" x 3"
19	NF Steel Bolt	HEX	5310000364-00	7/16" x 1"
20	NF Steel Bolt	HEX	5310000384-00	7/16" x 2-3/4"
21	NC Steel Bolt	HEX	5310000345-00	1/2" x 1-1/2"
22	NC Steel Bolt	HEX	5310000346-00	1/2" x 1-3/4"
24	Copper Flat Washer		5320000111-00	M8 x 12 x 1.5
25	Flat Washer		5320000106-00	5/16" x 17 x 2
26	Flat Washer		5320000096-00	5/16" x 21 x 2.2
27	Flat Washer		5320000050-00	5/16" x 30 x 3
28	Cone Washer		0000520002-00	5/16" (M8)
29	Flat Washer		5320000046-00	3/8" x 21 x 3
30	Flat Washer		5320000039-00	3/8" x 30 x 3
31	Flat Washer		5320000097-00	7/16" x 23 x 3
32	Flat Washer		5320000037-00	1/4" x 16 x 1
33	Flat Washer		5320000048-00	1/4" x 20 x 2
34	Flat Washer		5320000107-00	1/2" x 25 x 3
35	Galvanized Star Washer		5320000102-00	1/2"
36	NC Shoulder Nut		5330000052-00	1/4"
37	NC Shoulder Nut		5330000051-00	5/16"
38	NC Shoulder Nut		5330000043-00	3/8"
39	NC Shoulder Nut		5330000044-00	1/2"
40	NC Shoulder Nut		5330000055-00	5/8"
41	NC Steel Bolt	HEX	5310000383-00	5/8" x 2-1/2"
42	Galvanized Star Washer		5320000103-00	5/8"

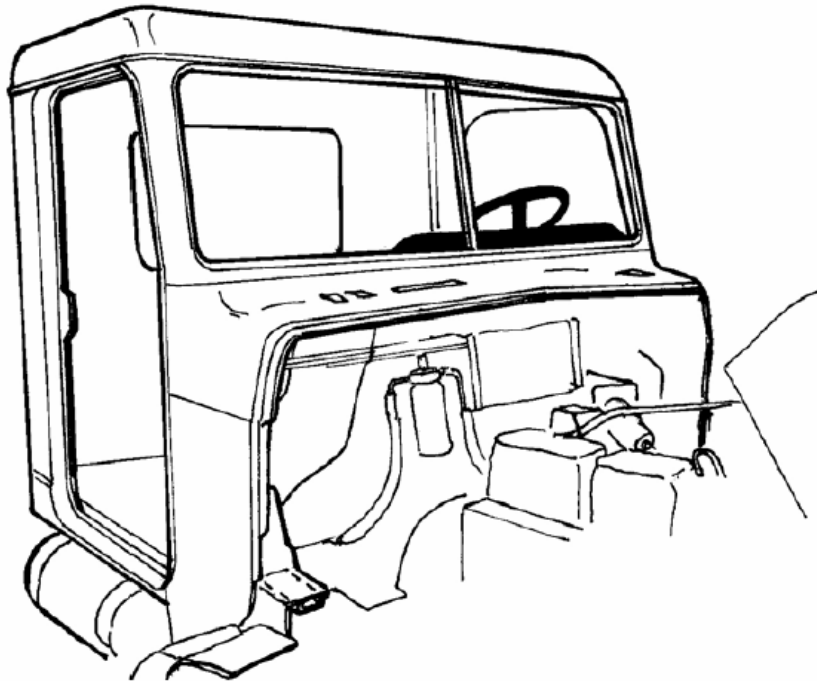
No.	Type	Head	Part No.	Size
43	Flat Washer		5320000110-00	5/8" x 32 x 2.5
44	NC Steel Bolt	Button Head Allen Bolt	5310000381-00	5/16" x 1-1/2"
45	NF Nut		5330000035-00	7/16"
47	NC Steel Bolt	HEX	5310000351-00	3/4" x 2"
48	NC Steel Bolt	HEX	5310000367-00	3/4" x 100
49	Flat Washer		5320000108-00	3/4" x 25 x 3
50	NC Steel Nut			7/16"
51	NC Steel Bolt	HEX		1/2" x 2-1/2"
52	NC Steel Bolt	HEX		1/2" x 3-1/2"
53	NC Steel Bolt	HEX		1/4" x 1/2"
54	NC Steel Bolt	HEX		5/8" x 2-3/4"
55	NC S-Lock, Shld. Nut			5/8"
56	NC Steel Screw	Button Head Allen		1/4" x 1/2"
57	NC Steel Screw	Button Head Allen		1/4" x 1"
58	Self-Tapping Screw	Phillips		#10 x 1/2"
59	NC Steel Screw	Button Head Allen		#10 x 3/4"
60	NC Self-Locking Nut			#10
61	Flat Washer			#10
62	NC Self-Locking Nut			1/4"
63	NC Self-Locking Nut			1/2"
64	NC Shld. Nut, Locking	HEX		7/16"
65	NC Lock Nut			5/16"
66	NC Steel Bolt	HEX		5/16" x 2"
67	NF Steel Bolt	HEX		7/16" x 1-1/2"
68	NC Steel Bolt	Socket Head Cap		1/4" x 1"

## 4. Kit Installation Checklist

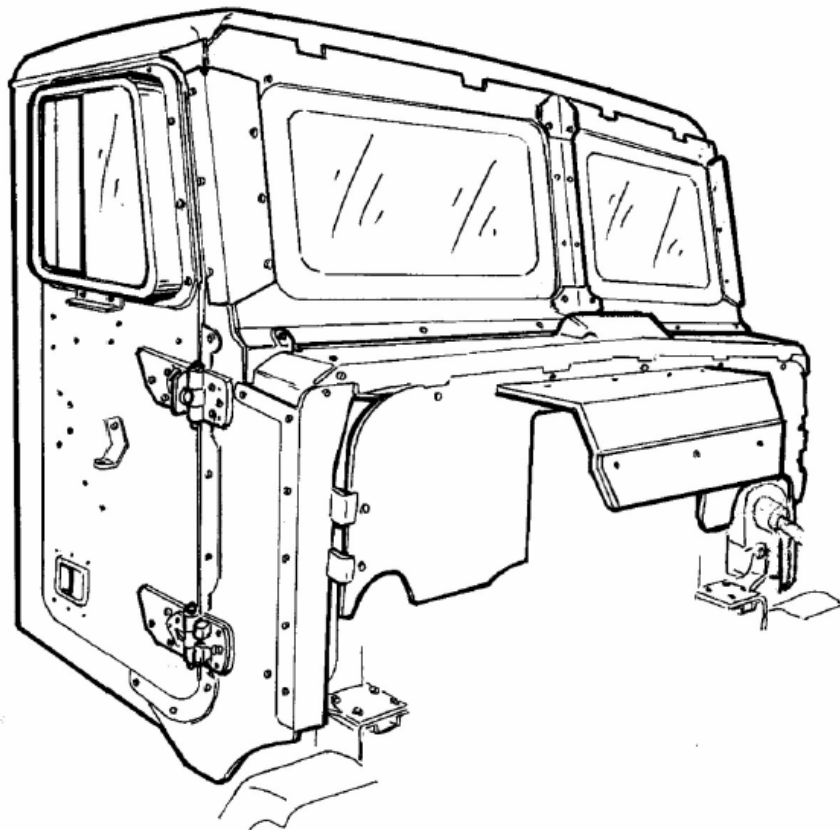
This chapter summarizes all the steps in the installation of the Crew Protection Kit.

**Table 4-1. Kit Installation Checklist**

No.	Description	Refer To
1. Section	5.1: Cab Support Reinforcement	Page 23
2. Section	5.2: RH Wheel Housing Kit Installation	Page 26
3. Section	5.3: LH Wheel Housing Kit Installation	Page 30
4. Section	5.4: Floor Kit Installation	Page 33
5. Section	5.5: RH Kit Installation	Page 36
6. Section	5.6: LH Kit Installation	Page 39
7. Section	5.7: Backside Kit Installation	Page 42
8. Section	5.8: Roof Kit Installation	Page 45
9. Section	5.9: Windscreen Bars & Brackets Installation	Page 51
10. Section	5.10: Firewall Kit Installation	Page 54
11. Section	5.11: Emergency Exit Kit Installation	Page 57
12. Section	5.12: Front Cowl Kit Installation	Page 61
13. Section	5.13: RH Cowl Kit Installation	Page 63
14. Section	5.14: LH Cowl Kit Installation	Page 67
15. Section	5.15: Front Cover Kit Installation	Page 71
16. Section	5.16: Windscreen Kit Installation	Page 74
17. Section	5.17: Seats Installation	Page 78
18. Section	5.18: RH Armored Door Installation	Page 80
19. Section	5.19: RH Door Accessories Assembly	Page 84
20. Section	5.20: LH Armored Door Installation	Page 87
21. Section	5.21: LH Door Accessories Assembly	Page 90
22. Section	5.22: Insulators Installation	Page 93
23. Section	5.23: Kit Installation Completion	Page 97



**Figure 4-1. General View before Kit Installation.**



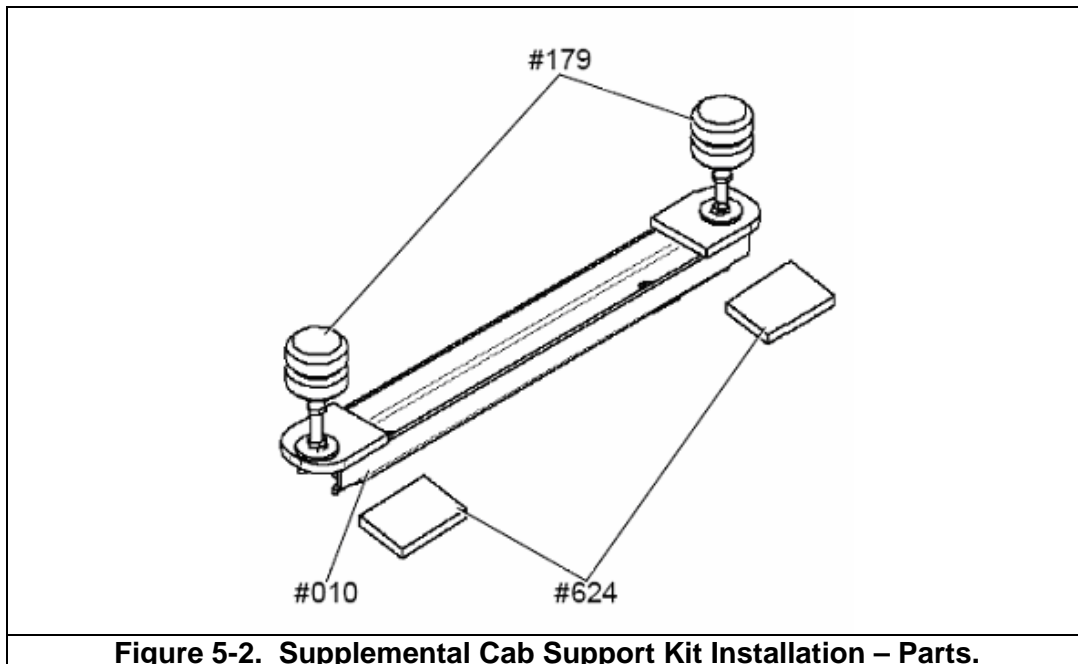
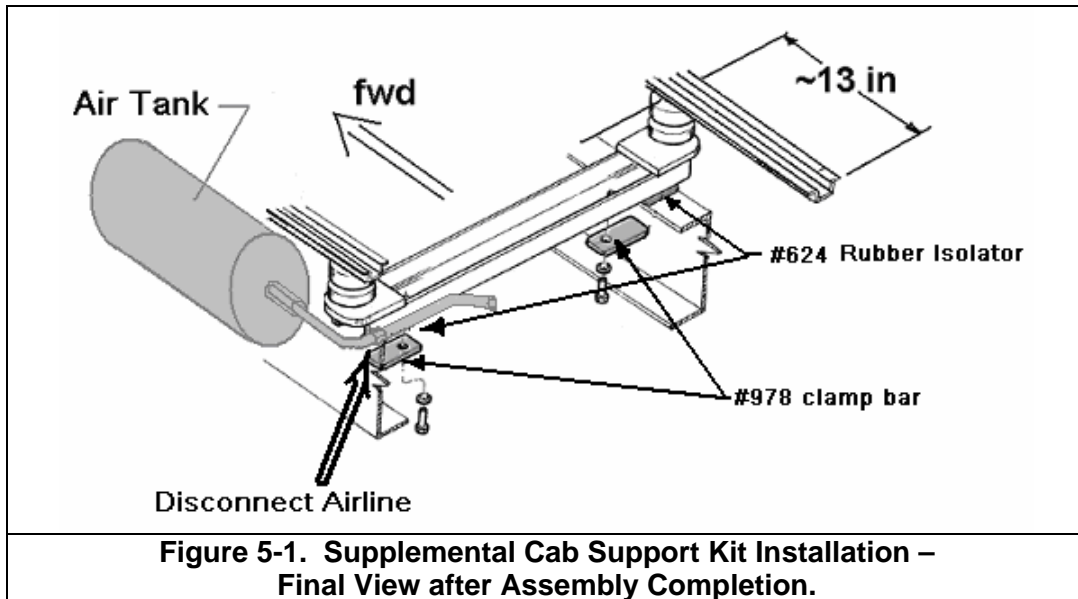
**Figure 4-2. General View after Kit Installation.**

## 5. Installation Procedure

This chapter provides sequential step-by-step instructions, accompanied with illustrations, on how to install each kit subassembly. The instructions should be followed in the sequence described in this manual. Where appropriate, steps in this chapter may be replaced with steps from Chapter 7 when installing this kit on the M915-A2 or M916-A1 models.

### 5.1 Supplemental Cab Support Kit Installation

**Note:** For the M916-A1 models, perform the cab support preparation work described in Section 7.1 prior to this step.



### 5.1.1 Parts, Fasteners, Special Tools, and Materials

<b>Parts</b> (see Figure 5-2):				
<b>Part No.</b>	<b>Alternate Part No.</b>	<b>Description</b>	<b>Find No. in Procedure</b>	<b>Quantity</b>
0257970010-00		Cab Support Assy	#010	1
0257100978-00*		Plate, Frame Clamp	#978	2
0257100624-00*		Spacer, Polyurethane	#624	2
5340000179-00*		Rubber Bumper	#179	2
<b>Fasteners:</b> (see Figures 5.6, 5.6a)				
<b>Find No. (Table 3-5)</b>	<b>Description</b>	<b>Size</b>	<b>Quantity</b>	
NA*	Bolt	3/4" x 2"	2	
NA*	Star Washer	3/4"	2	
NA*	Flat Washer	3/4"	2	
NA*	Shoulder Nut, NC	3/4"	2	
<b>Special Tools:</b>				
<b>Description</b>		<b>Vendor/Part-Number</b>		
None				

\*Components and fasteners are supplied as part of the 0127970010-00 assembly

### 5.1.2 Hazards Summary

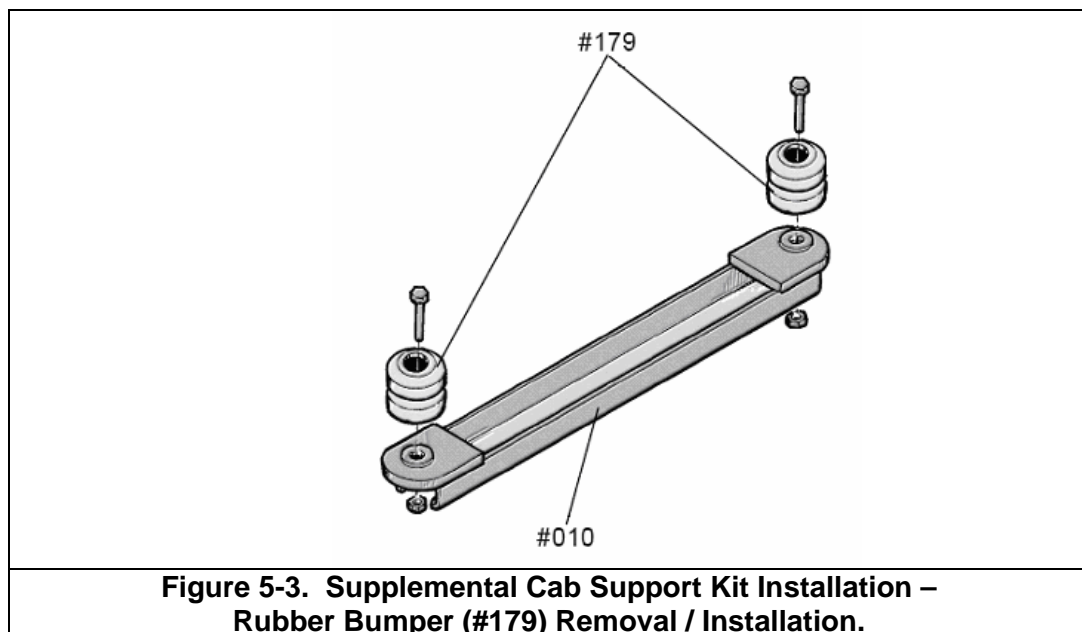
None.



### 5.1.3 Installation Instructions

**Note:** Parts are identified by their part number's last 3 digits

- 1) Remove clamp, part #978 from the cab support assembly by unscrewing the associated bolts.
- 2) Apply a small amount of grease on the upper side of the Rubber Bumper - part #179.
- 3) Relieve pressure from the truck air system. Once the air pressure has been bled, disconnect the air line from the aft end of the air tank located under the driver's side of the cab. Loosen the straps securing the air tank and slide the tank forward approximately 6 in.
- 4) Place the assembly between the Truck's Chassis and the Cabin Beam. The assembly should be located immediately aft of the air tank, approximately 13 in. forward of the aft end of the cabin floor stiffeners, parallel to the chassis. It is necessary to insert the assembly between the cab and frame rails while the assembly is lying on its side (see Figure 5.3a) and then rotate the assembly 90 deg about the long axis.
- 5) Insert part #624 between the top of the truck frame rail and the bottom of cab support assembly, item #010. It is necessary to use a pry bar to lift item #010 enough for the spacer #624 to be inserted.
- 6) Reattach part #978 so that it is clamped against the bottom surface of the top flange of the frame rail. Apply thread-locking compound to the clamp bolts before assembly.
- 7) Tighten the clamp bolts to a Torque of 160 N-m (120 ft-lb).
- 8) Reposition the air tank to its original position. Tighten the tank straps and reconnect the air line to the aft end of the tank.



## 5.2 Installing the RH Wheel Housing

**Note:** For M915-A2 and M916-A1 models, perform Step 7.2 prior to this step.

**Note:** The following instructions are specifically for installation on the M915-A3. For installation on M915-A2 and M916-A1 models, replace this step with Step 7.3.

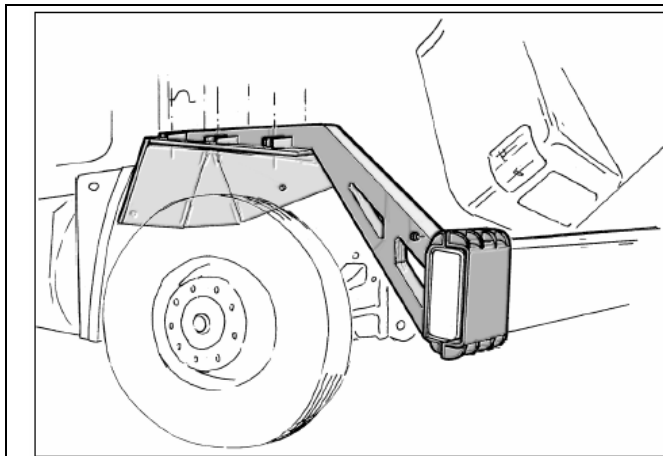


Figure 5-4. Installing the RH Wheel Housing – Final View after Assembly Completion.

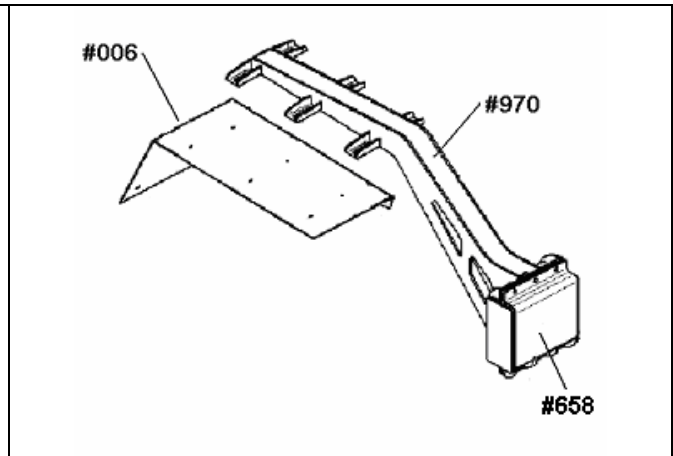



Figure 5-5. Installing the RH Wheel Housing – Parts.

### 5.2.1 Parts, Fasteners, Special Tools, and Materials

**Parts** (see Figure 5-5):


Part No.	Alternate Part No.	Description	Find No. in Procedure	Quantity
0257970006-00		Wheel Zone Deflector, RH	#006	1
0257970658-00		Support RH	#658	1
0257970970-00		Arm, WZD Support	#970	1

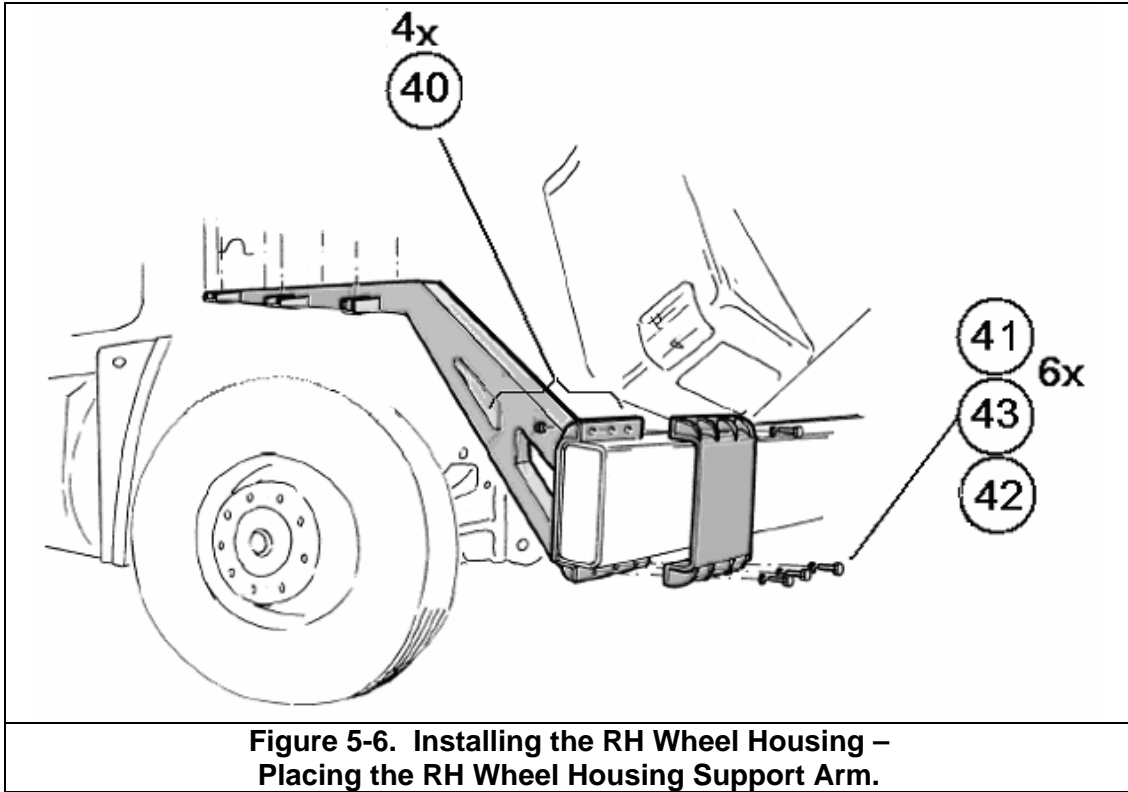
<b>Fasteners</b> (see Chapter 6 for fasteners map)			
<b>Find No.</b>	<b>Description</b>	<b>Size (P/N in Procedure - last 3 digits)</b>	<b>Quantity</b>
22	Bolt	1/2" x 1-3/4"	6
41	Bolt	5/8" x 2-1/2"	6
35	Star-Washer	1/2"	6
42	Star-Washer	5/8"	6
34	Flat-Washer	1/2" x 1" x 1/8"	6
43	Flat-Washer	5/8" x 1-1/4" x 1/8"	6
39	Nut	1/2"	6
40	Nut	5/8"	4
<b>Special Tools:</b>			
<b>Description</b>		<b>Vendor/Part-Number</b>	
Lifting device capable of lifting approximately 110 Kg (242 lb)		Commercial	

	<p><b>LIFT HAZARD</b></p> <p>Use proper lifting device with capacity of no less than 110 kg (242 lb) to lift the wheel housing kit.</p>
--	---


### 5.2.2 Installation Instructions

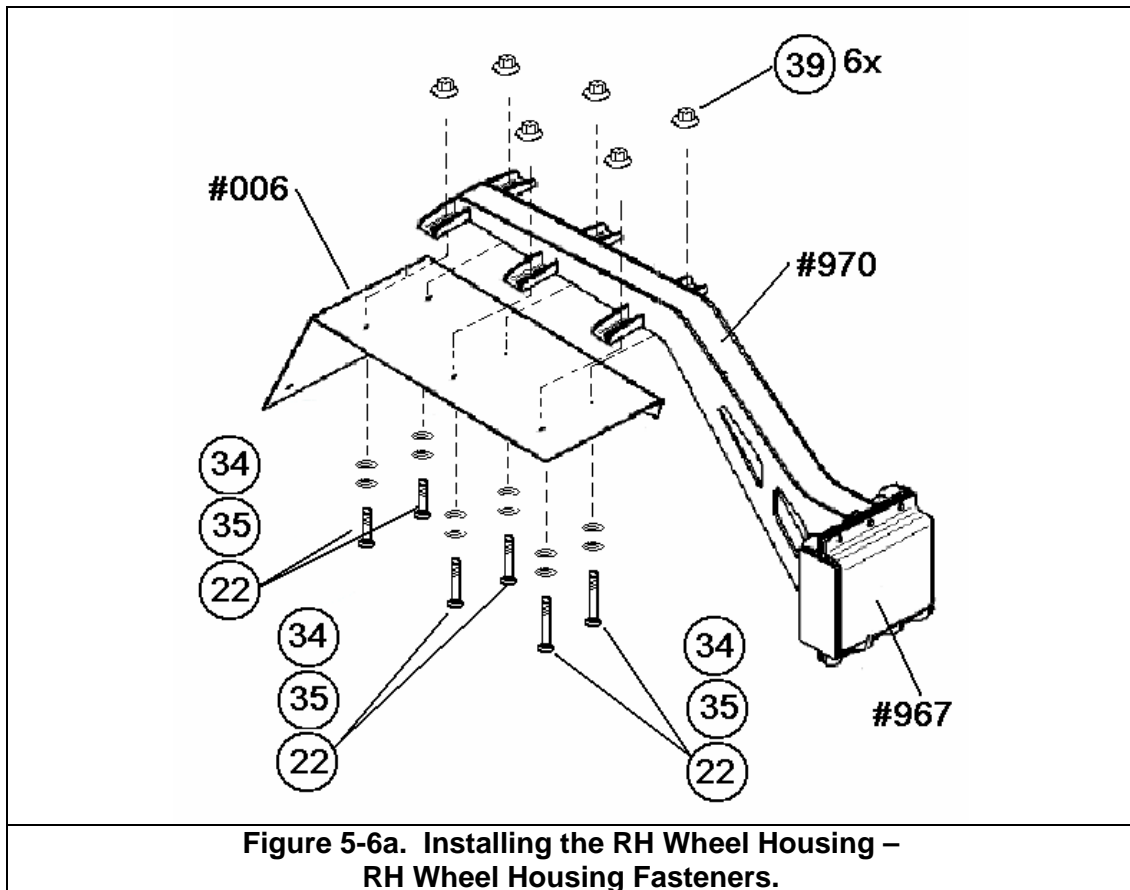
- 1) Arrange parts and fasteners at the installation location.
- 2) Prepare a lifting device capable of lifting approximately 110 kg (242 lb).
- 3) Place part #658 on the front bumper. Align item #970 with the front bumper outboard edge (see Figure 5-6).
- 4) Connect part #658 with part #970 using six (6) 5/8" x 2-1/2" bolts, 5/8" Star-Washers, 5/8" x 1-1/4" x 1/8" Flat-Washers, and 5/8" nuts. Arrange fasteners in the following order: Bolt, Star-Washer, Flat-Washer, Bracket Assembly, and Nut. Install all 6 bolts and associated nuts and washers. Tighten the top 3 bolts first, and then tighten the lower 3 bolts. Torque to 230 Nm (170 ft-lb). Note: Thread-locking compound must be used on these fasteners.

	<p><b>IMPORTANT</b></p> <p><i>Raise the rear end of part #970 as high as possible before connecting with part #658.</i></p>
---	---



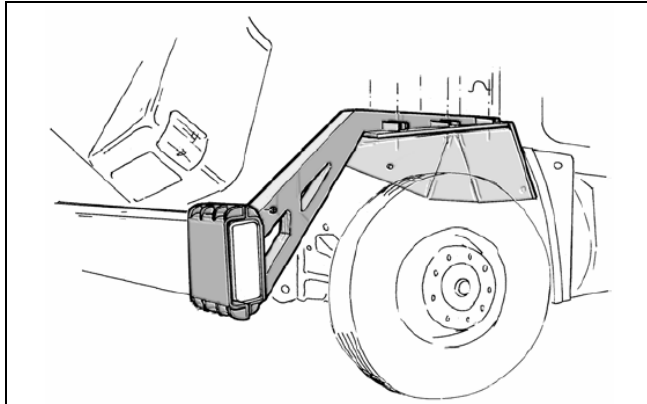
- 5) Lift item #006 into position as shown in Figure 5-6a. Insert the aft-most bolts first (item 22). Temporarily use the aft-most fasteners to hold the deflector in position. Install the center and forward fasteners next (do not tighten the bolts until all fasteners are in place). Apply thread-locking compound to each bolt. Install fasteners in the following order:
  - Star-Washer
  - Flat-Washer
  - Insert bolt from beneath
  - Nut.
- 6) Tighten bolts to a 122 N-m (90 ft-lb) torque.
- 7) Ensure that the flexible brake lines are not rubbing on the inside lower edge of the Wheel Zone Deflector (#006). If the lines are rubbing are near the Wheel Zone Deflector, relocate them by loosening the hose end fitting, twisting the lines and then re-tightening the hose end fittings.

	<p><b>WARNING</b></p> <p>Ensure that the flexible brake lines are not rubbing on the inside lower edge of the Wheel Zone Deflector (#006). If the lines are rubbing are near the Wheel Zone Deflector, reposition the hose path by loosening the hose end fitting, twisting the lines, and then re-tightening the hose end fittings</p>
---	---

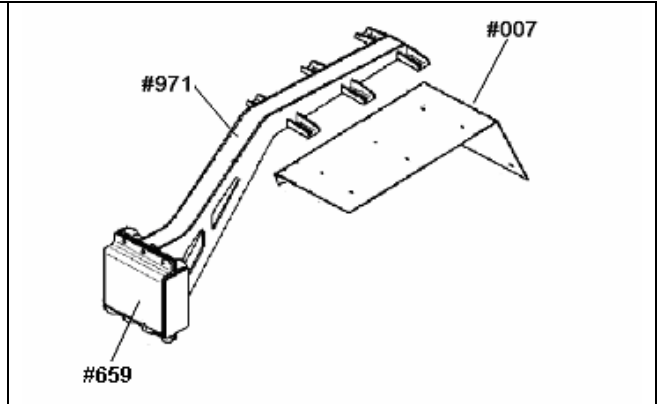


### 5.3 LH Wheel Housing Installation

**Note:** The following instructions are specifically for installation on the M915-A3. For installation on M915-A2 and M916-A1 models, replace this step with Step 7.4.



**Figure 5-7. Installing the LH Wheel Housing - Final View after Assembly Completion.**



**Figure 5-8. Installing the LH Wheel Housing - Parts.**

#### 5.3.1 Parts, Fasteners, Special Tools, and Materials

Parts (see Figure 5-8):				
Part No.	Alternate Part No.	Description	Find No. in Procedure	Quantity
0257970007-00		Wheel Zone Deflector, LH	#007	1
0257970659-00		Support, LH	#659	1
0257970971-00		Arm, WZD Support, LH	#971	1
Fasteners (see Chapter 6 for fasteners map)				
Find No.	Description	Size (P/N in Procedure - last 3 digits)	Quantity	
22	Bolt	1/2" x 1-3/4"	6	
41	Bolt	5/8" x 2-1/2"	6	
35	Star-Washer	1/2"	6	
42	Star-Washer	5/8"	6	
34	Flat-Washer	1/2" x 1" x 1/8"	6	
43	Flat-Washer	5/8" x 1-1/4" x 1/8"	6	
39	Nut	1/2"	6	
40	Nut	5/8"	4	
Special Tools:				
Description		Vendor/Part-Number		
Lifting device capable of lifting approximately 110 kg (242 lb)		Commercial		

### 5.3.2 Installation Instructions:

1. Arrange parts and fasteners at the installation location.
2. Prepare a lifting device cable of lifting approximately 110 kg (242 lb).
3. Place part #659 on the front bumper. Align item #971 with the front bumper outboard edge.
4. Connect part #659 with part #971 using six (6) 5/8" x 2-1/2" bolts (#383), 5/8" Star-Washers, 5/8" x 1-1/4" x 1/8" Flat-Washers, and 5/8" Nuts. Fasteners are arranged in the following order: Bolt, Star-Washer, Flat-Washer, and Nut. Install all 6 bolts and associated nuts and washers. Tighten the top 3 bolts first, and then tighten the lower 3 bolts. Torque to 230 Nm (170 ft-lb). Note: Thread-locking compound must be used on these fasteners.
5. Lift item #007 into position as shown in Figure 5-9. Insert the aft-most bolts first (item 22). Temporarily use the aft fasteners to hold the deflector in position. Install the center and forward fasteners next (do not tighten the bolts until all fasteners are in place). Apply thread-locking compound to the bolts. Install fasteners in the following order:
  - Star-Washer
  - Flat-Washer
  - Insert bolt from beneath
  - Nut.
6. Tighten bolts to a 122 N-m (90 ft-lb) torque.
7. Ensure that the flexible brake lines are not rubbing on the inside lower edge of the Wheel Zone Deflector (#007). If the lines are rubbing near the Wheel Zone Deflector, relocate them by loosening the hose end fitting, twisting the lines and then re-tightening the hose end fittings



#### **IMPORTANT**

Raise the rear end of part #971 as high as possible before connecting with part #659



#### **WARNING**

Ensure that the flexible brake lines are not rubbing on the inside lower edge of the Wheel Zone Deflector (#006). If the lines are rubbing are near the Wheel Zone Deflector, reposition the hose path by loosening the hose end fitting, twisting the lines and then re-tightening the hose end fittings.

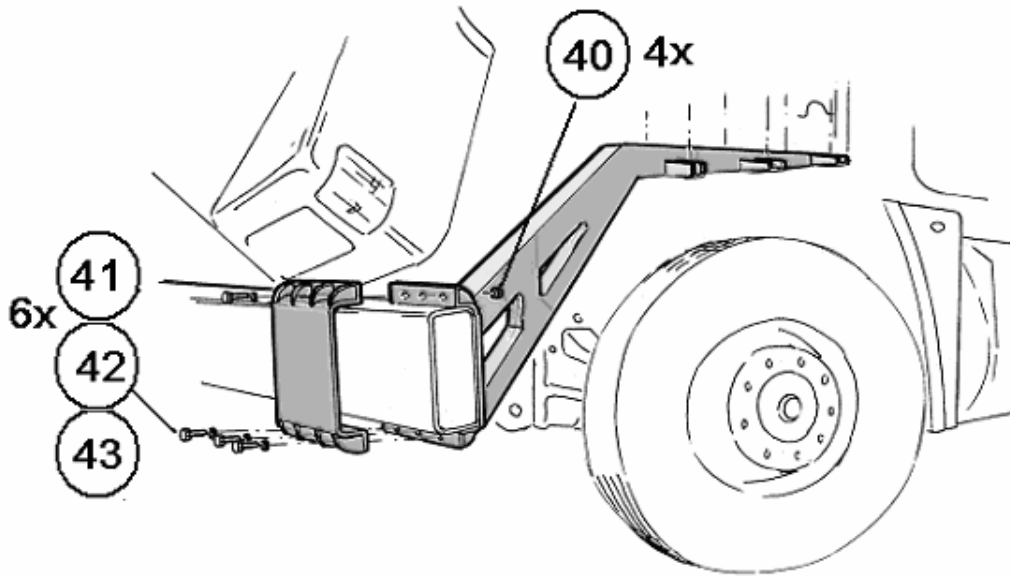


Figure 5-9. Installing the LH Wheel Housing - Placing the LH Wheel Housing Support Arm.

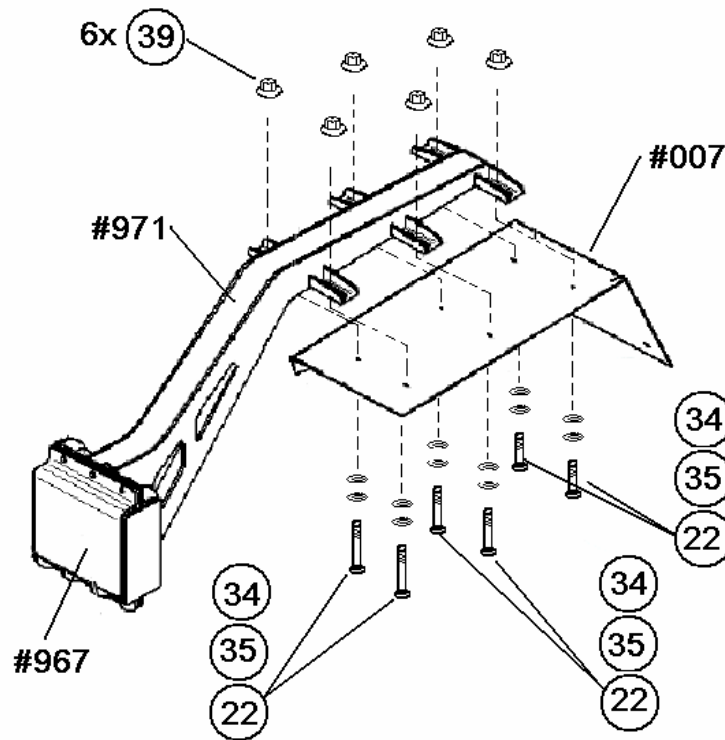
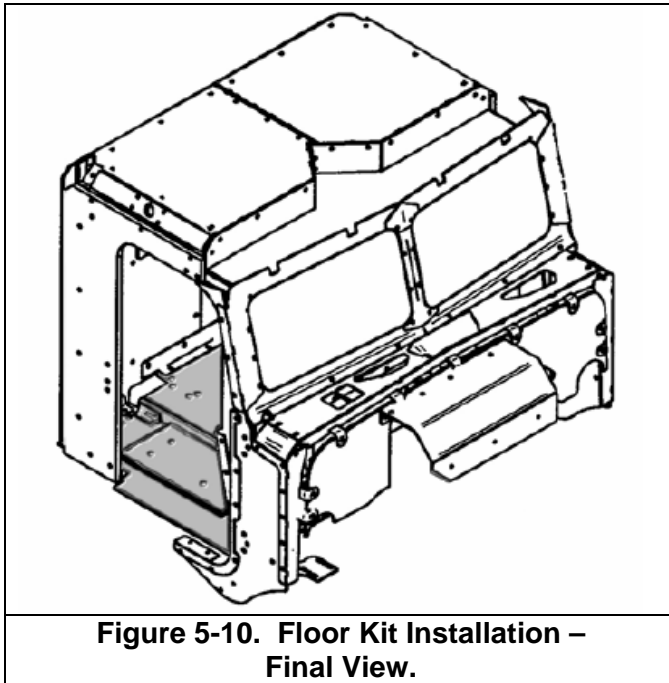


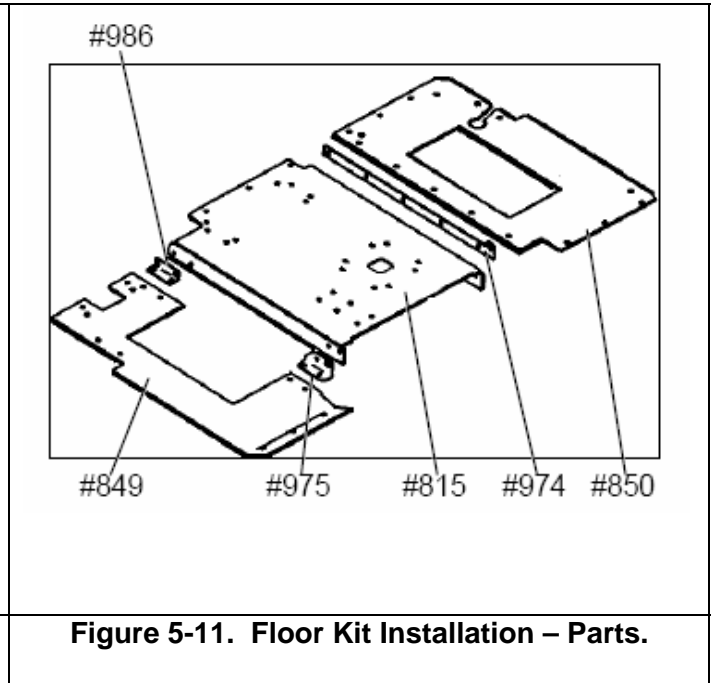
Figure 5-9a. Installing the LH Wheel Housing - LH Wheel Housing Fasteners.



## 5.4 Floor Kit Installation



**Figure 5-10. Floor Kit Installation – Final View.**



**Figure 5-11. Floor Kit Installation – Parts.**

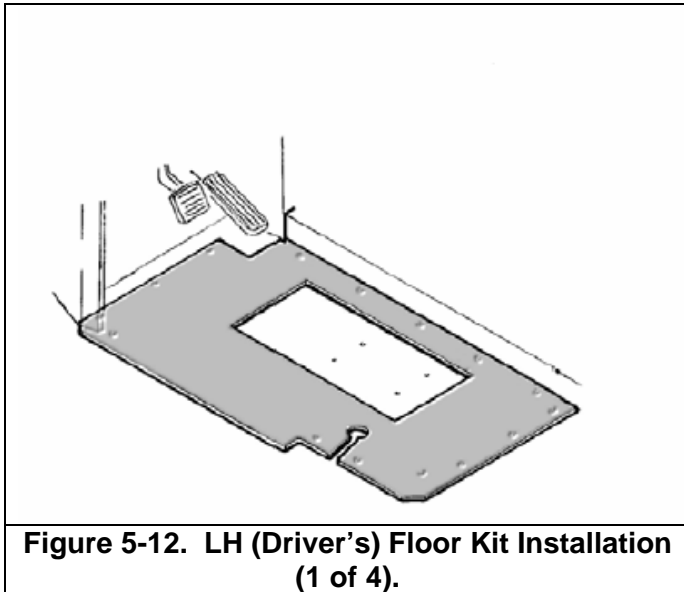
### 5.4.1 Parts, Fasteners, Special Tools, and Materials

Parts (see Figure 5-11)				
Part No.	Alternate Part No.	Description	Find No. in Procedure	Quantity
0257120815-00		Floor, Middle	#815	1
0257120849-00		Floor, Passenger, RH	#849	1
0257120850-00		Floor, Driver, LH	#850	1
0257120974-00		Bracket, Floor, Driver to Middle	#974	1
0257120975-00		Bracket, Front, Floor, Passenger to Middle	#975	1
0257120986-00		Bracket, Rear, Floor, Passenger to Middle	#986	1

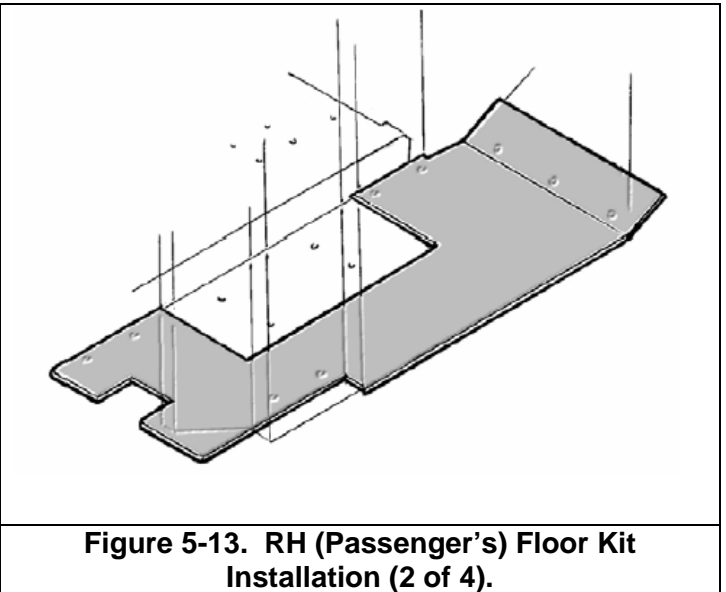
<b>Fasteners:</b>			
<b>Find No. (Table 3-5)</b>	<b>Description</b>	<b>Size</b>	<b>Quantity</b>
3	Bolt	5/16" x 1" UNC	17
26	Flat Washer	5/16" x 21 x 2.2	17
<b>Special Tools/ Materials</b>			
<b>Description:</b>		<b>Vendor/Part-Number:</b>	
None			

### 5.4.2 Installation Instructions:

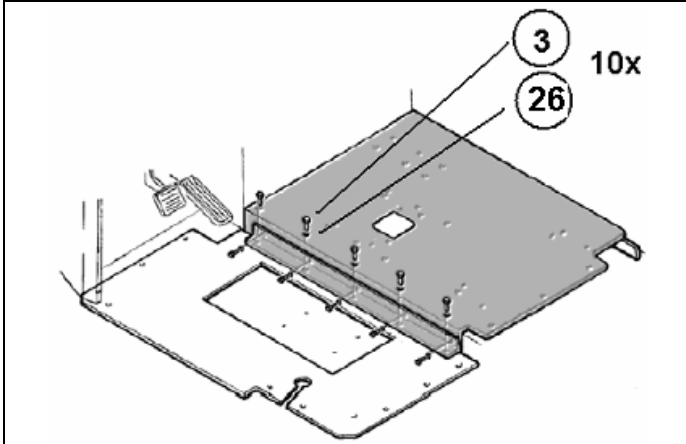
1. Position the right, left, and center floor panels as shown in Figures 5-12, 5-12, and 5-13.
2. Position bracket #974 between the driver's-side floor panel (#850) and the center panel (#815) as shown in Figure 5-14. Start the fasteners, but do not fully tighten them at this time.
3. Position brackets #975 and #986 between the passenger-side floor panel (#849) and the center floor panel (#815) as shown in Figure 5-15. Start the fasteners, but do not fully tighten them at this time



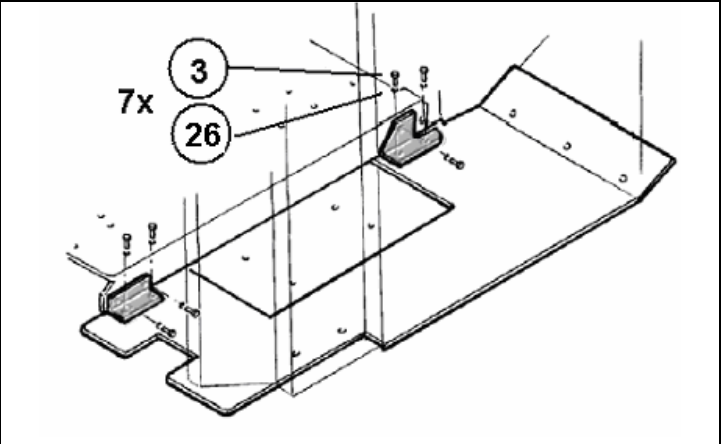
**Figure 5-12. LH (Driver's) Floor Kit Installation (1 of 4).**



**Figure 5-13. RH (Passenger's) Floor Kit Installation (2 of 4).**



**Figure 5-14. Floor Kit Installation (3 of 4).**



**Figure 5-15. Floor Kit Installation (4 of 4).**



**IMPORTANT**

After installation, cover the floor panels to minimize damage to the finish while completing the remainder of the kit installation.

## 5.5 RH Kit Installation

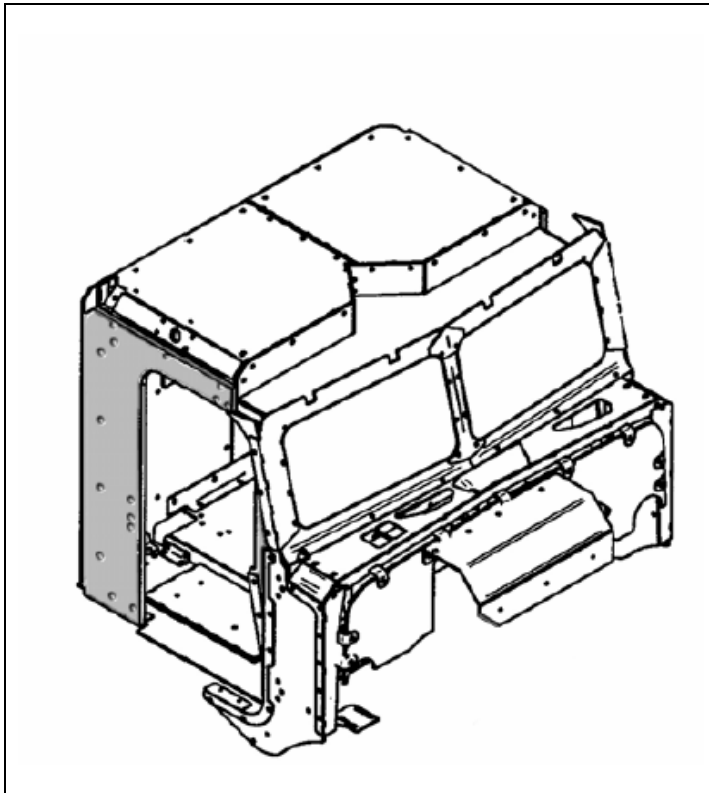


Figure 5-16. RH Kit Installation - Final View.

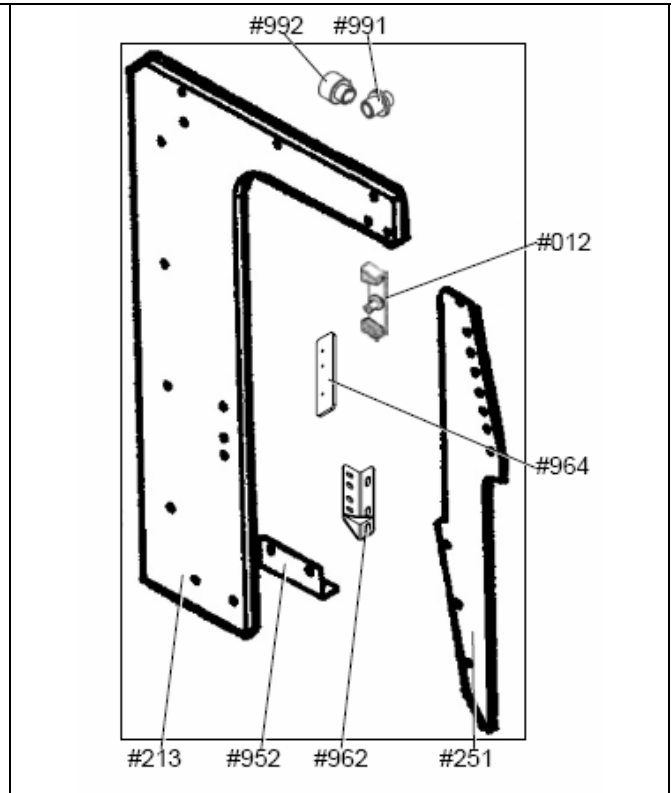


Figure 5-17. RH Kit Installation - Parts.

### 5.5.1 Parts, Fasteners, Special Tools, and Materials

Parts (see Figure 5-17)				
Part No.	Alternate Part No.	Description	Find No. in Procedure	Quantity
0257010012-00		Striker Assembly	#012	1
0257032213-00		Right Side Panel	#213	1
0257032251-00	0257037351-00	RH A-Pillar Panel	#251	1
0257030952-00		Bracket, Side Panel, RH	#952	1
0257030962-00		Lock Bracket, RH	#962	1
0257030964-00		Back Plate, Lock	#964	1
0257030991-00		Bushing, Seat Belt	#991	1
0257030992-00		Bushing, Seat belt	#992	1

<b>Fasteners:</b>			
<b>Find No. (Table 3-5)</b>	<b>Description</b>	<b>Size</b>	<b>Quantity</b>
18	Bolt	7/16" x 3 NF	1
31	Flat washer	7/16" x 23 x 3	2
17	Bolt	1/4" x 1-1/4" NC	4
32	Flat washer	1/4" x 16 x 1	4
6	Bolt	5/16" x 1-1/2" NC	2
64	Flange Nut, Locking	7/16" NC	1
27	Flat Washer	5/16" x 30 x 3	6
66	Bolt	5/16" x 2" NC	3
3	Bolt	5/16" x 1" NC	1
19	Bolt	7/16" x 1" NF	1
65	Nut, Locking	5/16" NC	1
26	Flat Washer	5/16" x 21 x 2.2	1
<b>Special Tools/ Materials</b>			
<b>Description:</b>		<b>Vendor/Part-Number:</b>	
None			

### 5.5.2 Installation Instructions:

1. Prior to installation of these components, it is necessary to modify the shoulder harness "comfort clip". Reference Figure 5-18. Using a 5/8-in.-diameter drill bit or tapered reamer, enlarge the existing mounting hole on the comfort clip from the current diameter (0.45 in.) to a new diameter of 5/8 in.
2. Install bushing #991 into the outboard facing surface of side panel, #213. Install bushing #992 into the inboard facing side of the side panel, #213 (see Figure 5-18). Note that the large-diameter end of #992 is inserted into the panel and the small diameter end faces away from the panel. These bushings are an interference fit and may require the use of a mallet or press.
3. Position the side panel (#213) in the cab against the interior cab wall as shown in Figure 5-18. Place washer 31 on fastener 18. Insert fastener 18 through the shoulder belt comfort clip, through the shoulder belt anchor fitting, and through bushings #991 and #992. Adjust the position of the side panel until the bolt aligns with the associated hole in the cab side wall. Once aligned, screw fastener 18 in sufficiently to retain the side panel, but do not tighten it at this time.
4. Place bracket #952 against the floor panel and the side panel as shown in Figure 5-19. Install the bolts and washers (6 and 26) through the bracket to the side wall.
5. Install one bolt and washers (19 and 31) and one bolt and washers (3 and 27) through the bracket to the floor panel. Note that the lower seat belt anchor should also be re-secured at this point as well.
6. Install the A-Pillar panel as shown in Figure 5-18. The A-Pillar armor panel fits between the outboard end of the instrument panel and the inside surface of the cab A-pillar. Install bolts and washers in every other hole as shown. It may be necessary to adjust the position of this panel slightly during the installation of the toe panels; thus, it is recommended that the bolts not be fully tightened at this time.

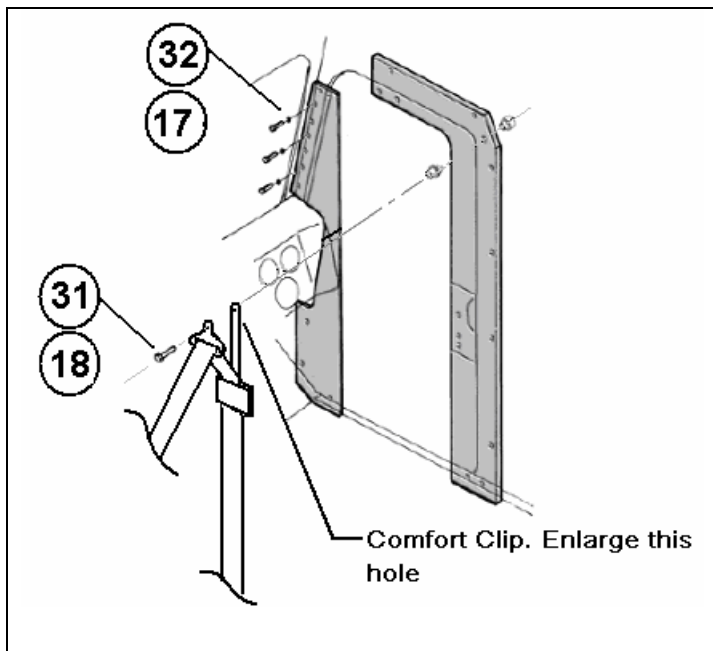


Figure 5-18. RH Kit Installation (1 of 3).

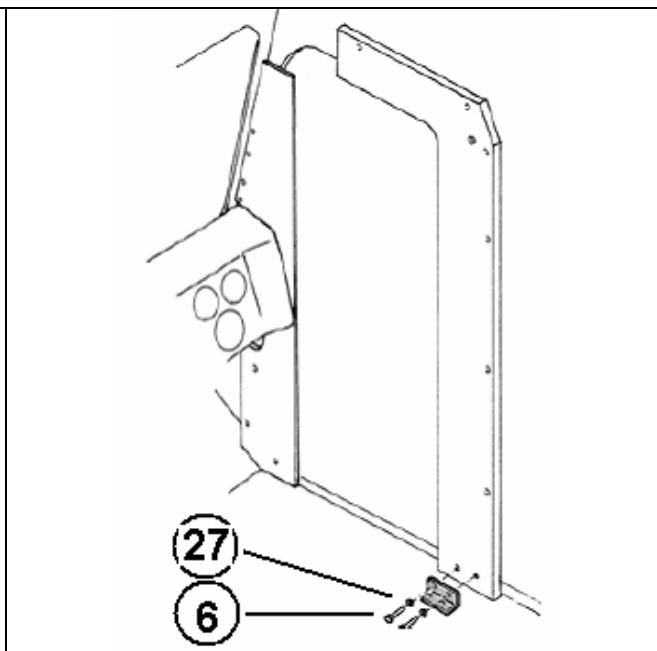


Figure 5-19. RH Kit Installation (2 of 3).

7. Ensure that panel #213 is aligned with the B pillar.
8. Temporarily secure Bracket #962 in position as shown in Figure 5-20 using the 2 lower fasteners. Mark the location for the upper hole on the B-pillar. Remove Bracket #962.
9. Drill a 9/16-in. hole through the B-pillar in the location marked.
10. Install fasteners and components as shown in Figure 5-20.

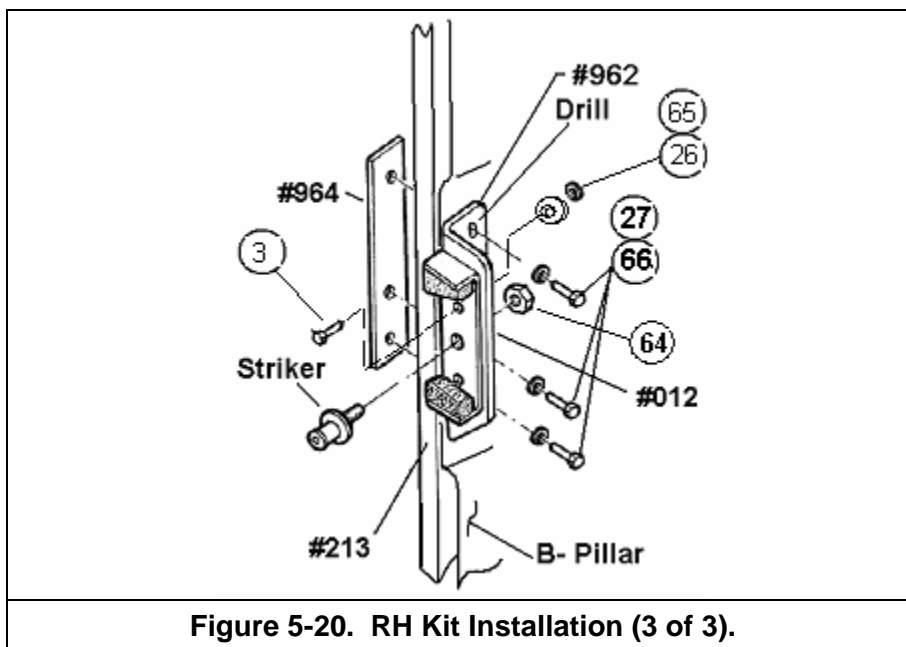


Figure 5-20. RH Kit Installation (3 of 3).

## 5.6 LH Kit Installation

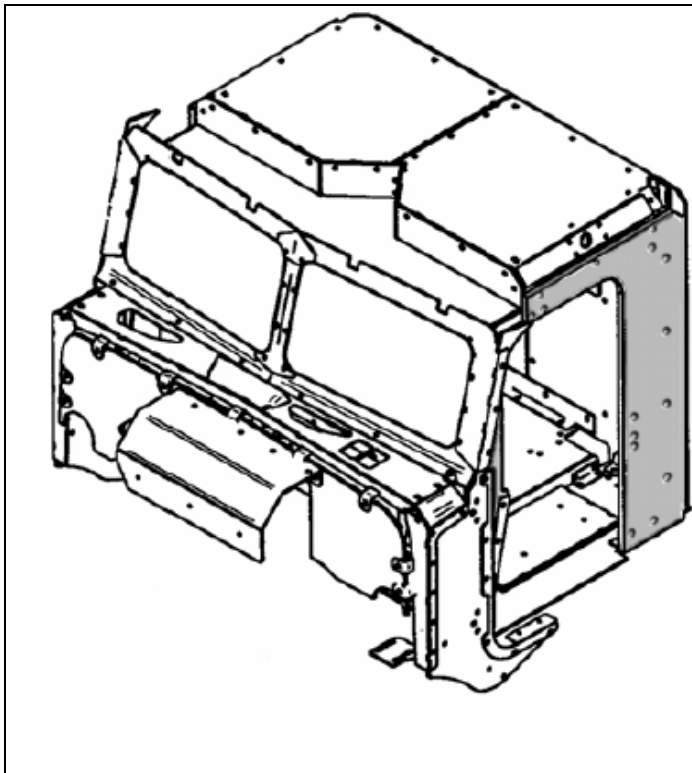


Figure 5-21. LH Kit Installation - Final View.

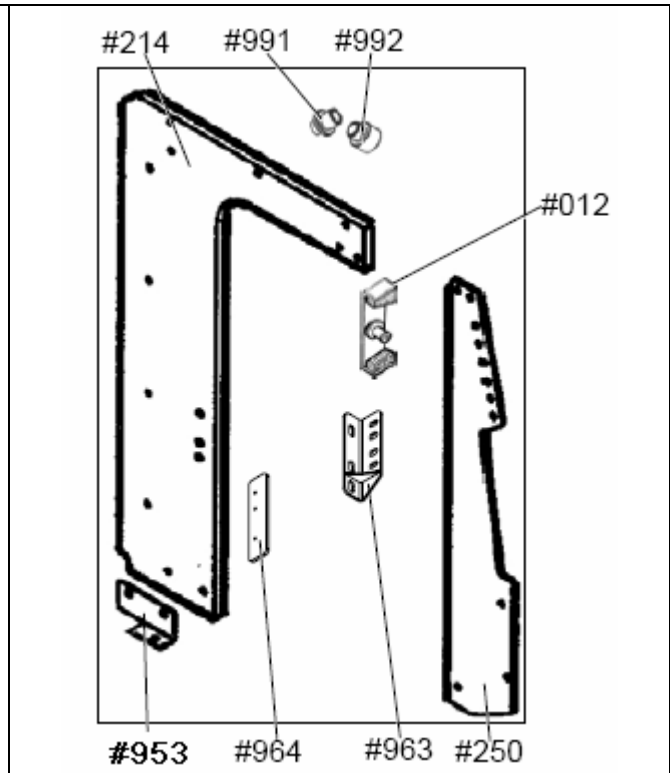


Figure 5-22. LH Kit Installation – Parts.

### 5.6.1 Parts, Fasteners, Special Tools, and Materials

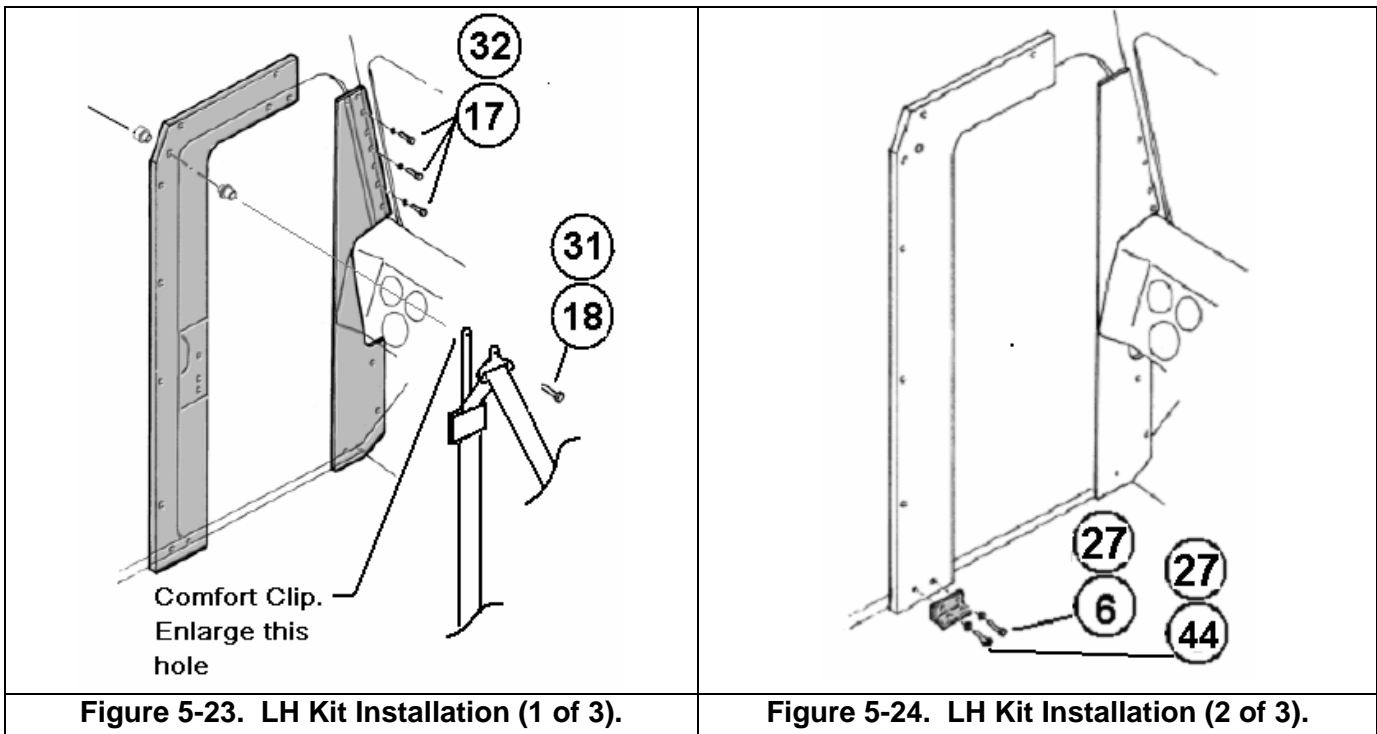
#### Parts (see Figure 5-22)

Part No.	Alternate Part No.	Description	Find No. in Procedure	Quantity
0257010012-00		Striker Assembly	#012	1
0257032214-00		Left Side Panel	#214	1
0257032250-00	0257037350-00	LH A-Pillar Panel	#250	1
0257030953-00		Bracket, Side Panel, LH	#953	1
0257030963-00		Lock Bracket, LH	#963	1
0257030964-00		Back Plate, Lock	#964	1
0257030991-00		Bushing, Seat Belt	#991	1
0257030992-00		Bushing, Seat belt	#992	1

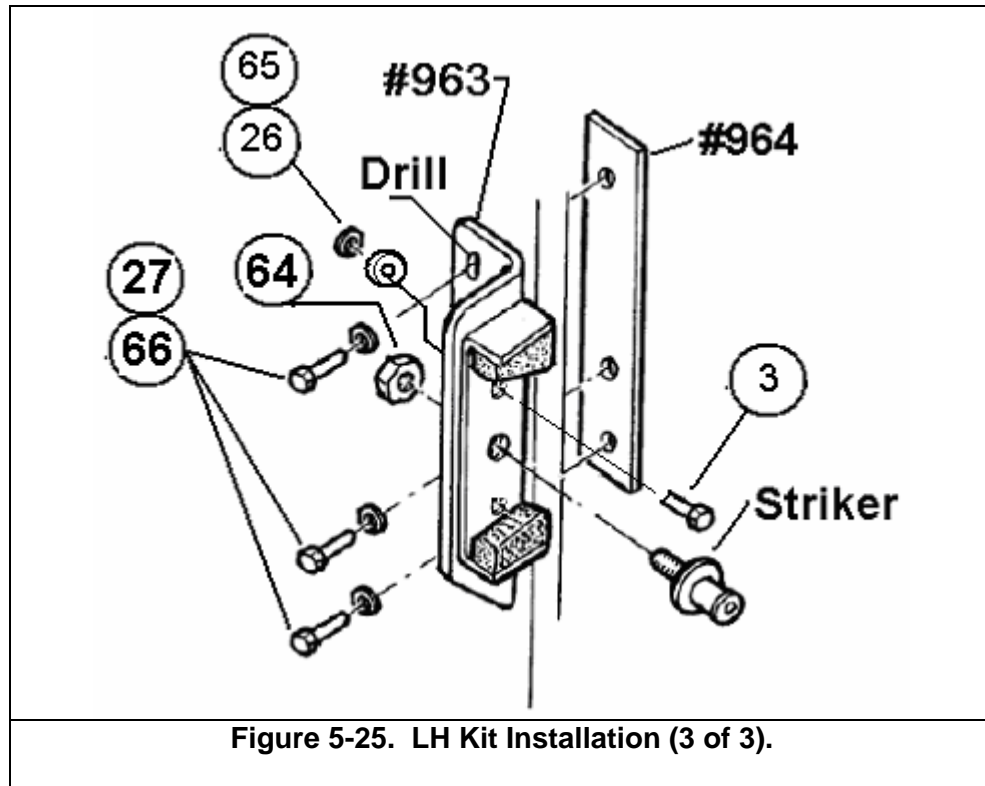
<b>Fasteners:</b>			
<b>Find No. (Table 3-5)</b>	<b>Description</b>	<b>Size</b>	<b>Quantity</b>
18	Bolt	7/16" x 3 NF	1
31	Flat washer	7/16" x 23 x 3	2
17	Bolt	1/4" x 1-1/4" NC	3
32	Flat washer	1/4" x 16 x 1	3
6	Bolt	5/16" x 1-1/2" NC	2
64	Flange Nut, Locking	7/16" NC	1
27	Flat Washer	5/16" x 30 x 3	5
66	Bolt	5/16" x 2" NC	3
19	Bolt	7/16" x 1" NF	1
44	Button-Head Allen Bolt	5/16" x 1-1/2" NC	1
65	Nut, Locking	5/16" NC	1
26	Flat Washer	5/16" x 21 x 2.2	1
3	Bolt	5/16" x 1" NC	1
<b>Special Tools/ Materials</b>			
<b>Description:</b>		<b>Vendor/Part-Number:</b>	
None			

### 5.6.2 Installation Instructions

1. Installation of the Left Hand side armor is the same as the Right Hand armor. Repeat the procedures in Section 5.5. Refer to Figures 5-22, 5-23, 5-24 and 5-25.







## 5.7 Backside Kit Installation

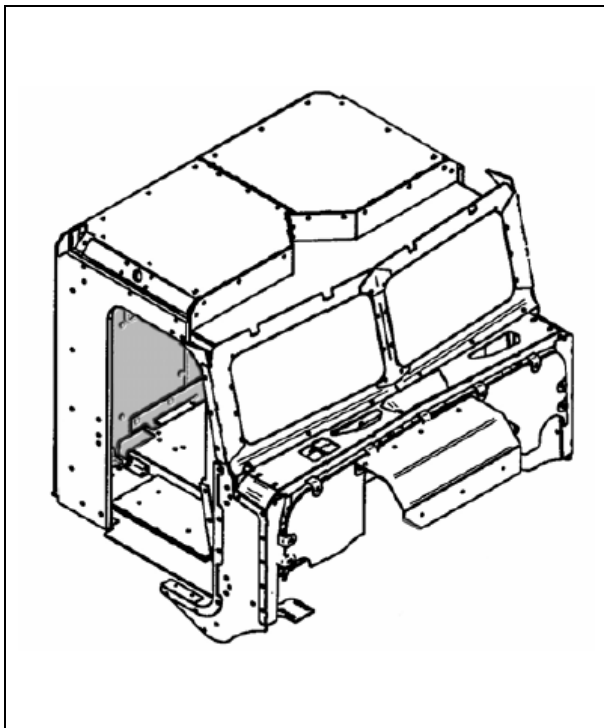


Figure 5-26. Backside Kit Installation - Final View.

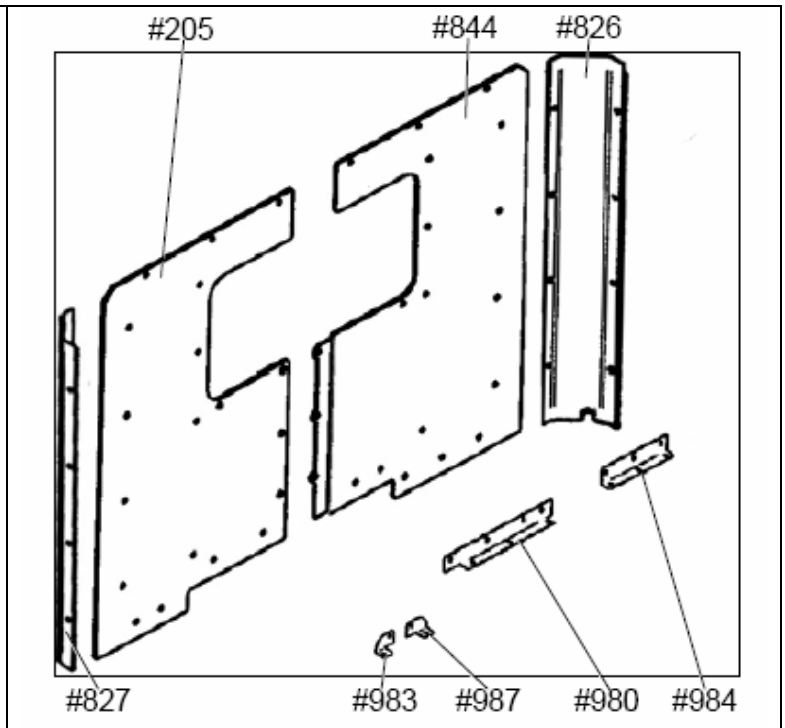


Figure 5-27. Backside Kit Installation – Parts.

### 5.7.1 Parts, Fasteners, Special Tools, and Materials

Parts (see Figure 5-27)				
Part No.	Alternate Part No.	Description	Find # in Procedure	Quantity
0257062205-00	0257062305-00	RH Rear Panel	#205	1
0257030826-00		Left Rear B Pillar	#826	1
0257030827-00		RH Rear B Pillar	#827	1
0257060844-00	0257060863-00	LH Rear Panel	#844	1
0257090980-00		Bracket, Middle Floor to Back 1	#980	1
0257120983-00		Bracket, RH Floor to Back	#983	1
0257120984-00		Bracket, LH Floor to Back	#984	1
0257120987-00		Bracket, Middle Floor to Back 2	#987	1

<b>Fasteners:</b>			
<b>Find No. (Table 3-5)</b>	<b>Description</b>	<b>Size</b>	<b>Quantity</b>
3	Bolt	5/16" x 1 NC	25
6	Bolt	5/16" x 1-1/2" NC	8
26	Flat washer	5/16" x 21 x 2.2	33
28	Cone washer	5/16"	3
12	Bolt counter sunk	5/16" x 1" NC	3
<b>Special Tools/ Materials</b>			
<b>Description:</b>		<b>Vendor/Part-Number:</b>	
None			

### 5.7.2 Installation Instructions

1. Place Panel #844 against the aft cabin wall, left corner, as shown in Figure 5-28. Align the left rear B-pillar #826. Install fasteners through the B-pillar and into the rear and side panel as shown. Do not torque fasteners at this time, as it may be necessary to adjust the panel positions slightly to align other components.
2. Place panel #205 against the aft cabin wall, right corner, as shown in Figure 5-29. Note that panel #205 will overlap panel #844 in the center. Align the right rear B-pillar #827. Install fasteners through the B-pillar and into rear and side panel as shown. Do not torque the fasteners at this time.
3. Install counter-sunk washers and screws (items 12 and 28) to connect the panels at the center joint.
4. Install brackets, #980, #983, #984 and #987 in locations as shown in Figure 5-27. Secure with bolts and washers as defined in Figure 5-30.

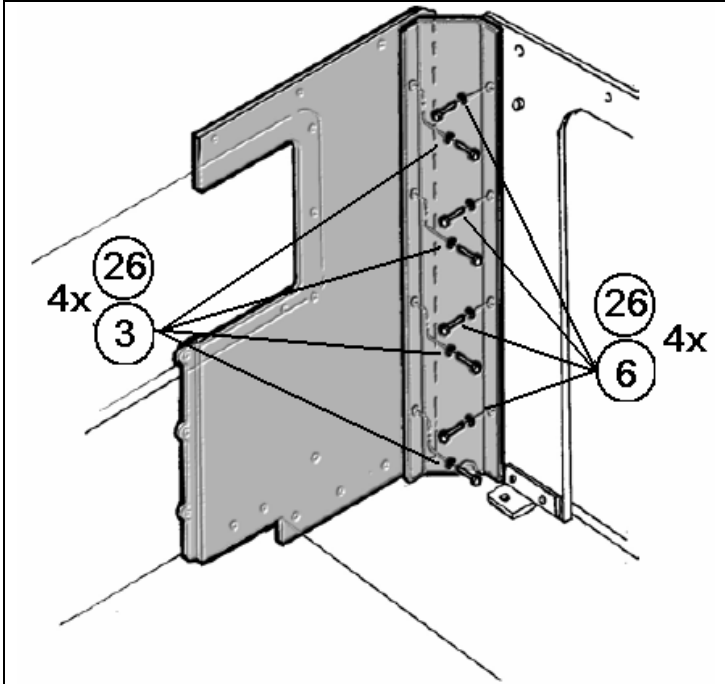


Figure 5-28. Backside Kit Installation (1 of 3).

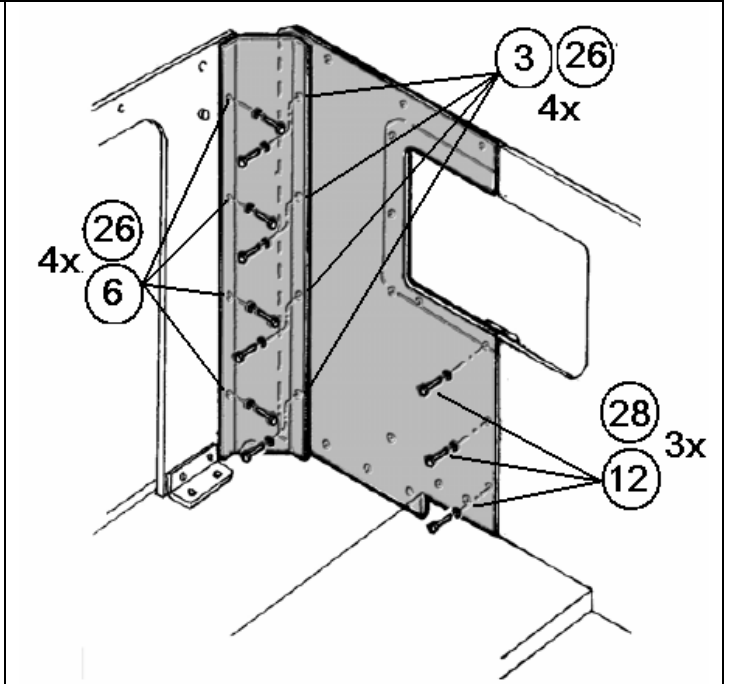


Figure 5-29. Backside Kit Installation (2 of 3).

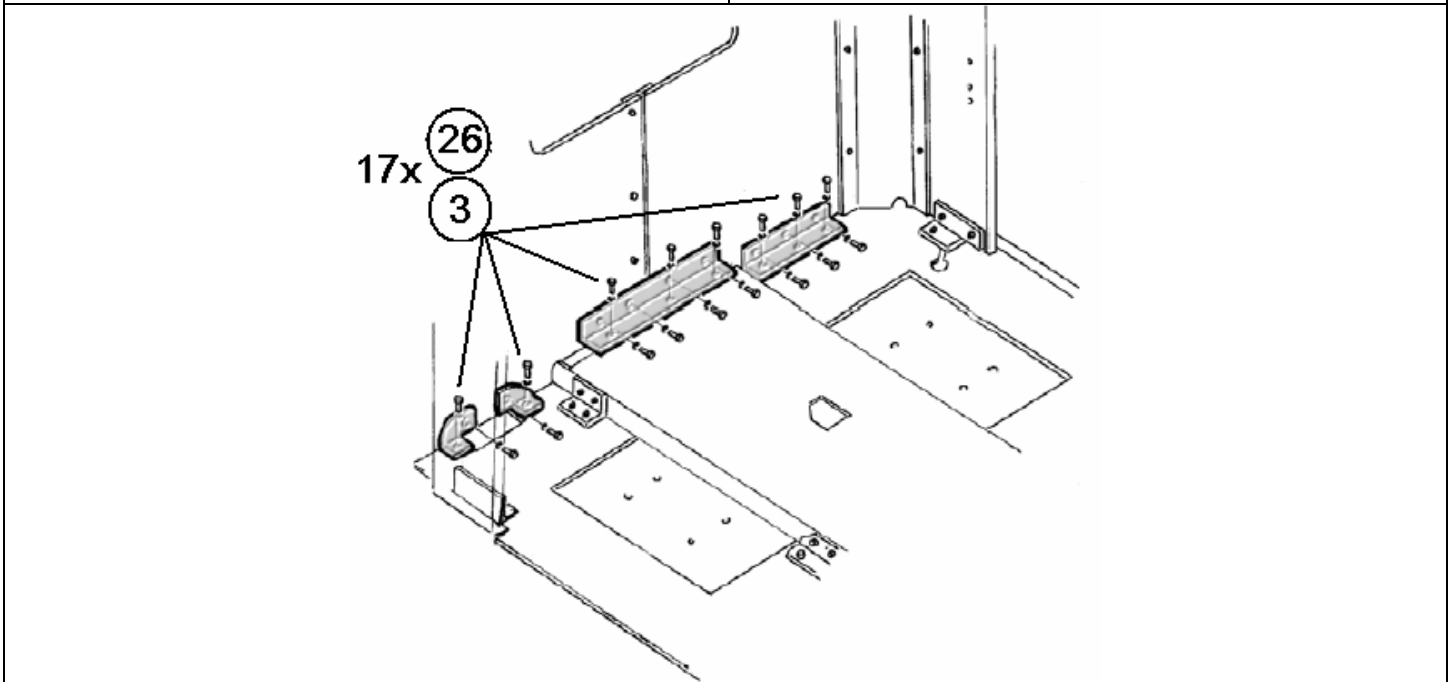
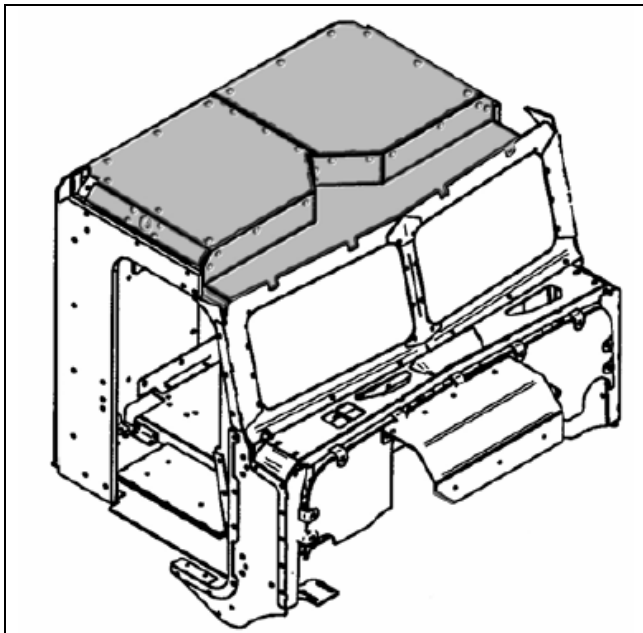
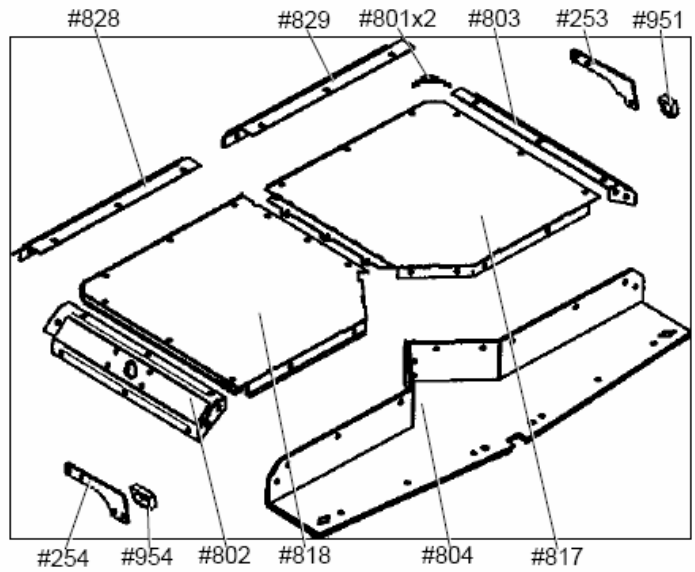


Figure 5-30. Backside Kit Installation (3 of 3).

## 5.8 Roof Kit Installation



**Figure 5-31. Roof Kit Installation – Final View.**




**Figure 5-32. Roof Kit Installation – Parts.**

### 5.8.1 Parts, Fasteners, Special Tools, and Materials

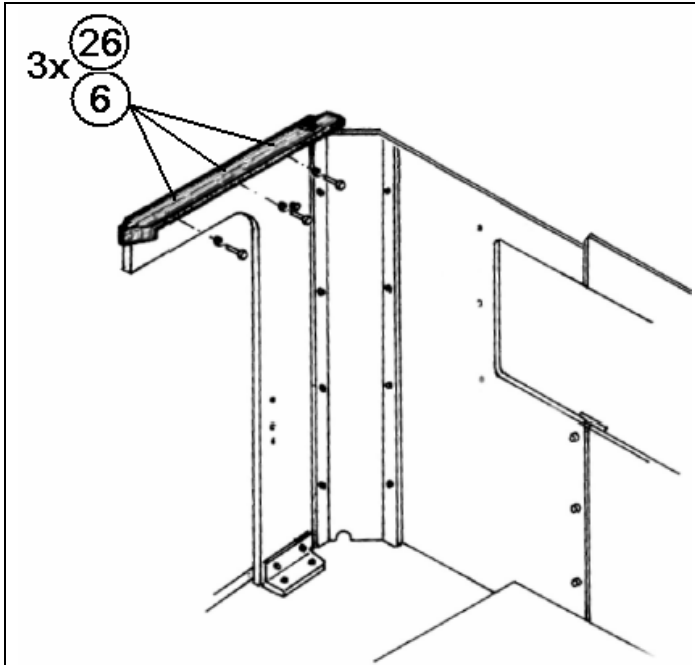
Parts (see Figure 5-32)				
Part No.	Alternate Part No.	Description	Find No. in Procedure	Quantity
0257032253-00	0257037353-00	RH A-Pillar Top, Internal	#253	1
0257032254-00	0257037354-00	LH A-Pillar Top, Internal	#254	1
0257010801-00		LH/RH Rear Roof Corner	#801	2
0257010802-00	0257010864-00	RH Side Roof Overlap	#802	1
0257010803-00	0257010865-00	LH Side Roof Overlap	#803	1
0257010804-00	0257010061-00	Front Roof Assembly	#804	1
0257010817-00		LH Rear Roof	#817	1
0257010818-00		RH Rear Roof	#818	1
0257010828-00	0257010866-00	RH Rear Roof Overlap	#828	1
0257010829-00	0257010867-00	LH Rear Roof Overlap	#829	1
0257030951-00		Spacer, RH A-Pillar Top Internal	#951	1
0257030954-00		Spacer, LH A-Pillar Top Internal	#954	1
0257550008-00		Roof Support Tool		1

<b>Fasteners:</b>			
<b>Find No. (Table 3-5)</b>	<b>Description</b>	<b>Size</b>	<b>Quantity</b>
6	Bolt	5/16" x 1-1/2" NC	6
26	Flat washer	5/16" x 21 x 3	48
2	Bolt	5/16" x 3/4" NC	19
3	Bolt	5/16" x 1" NC	16
10	Bolt	5/16" x 2-1/2" NC	3
8	Bolt	5/16" x 1-3/4" NC	4
<b>Special Tools/ Materials</b>			
<b>Description:</b>		<b>Vendor/Part-Number:</b>	
Telescopic Stand		0257550008-00	

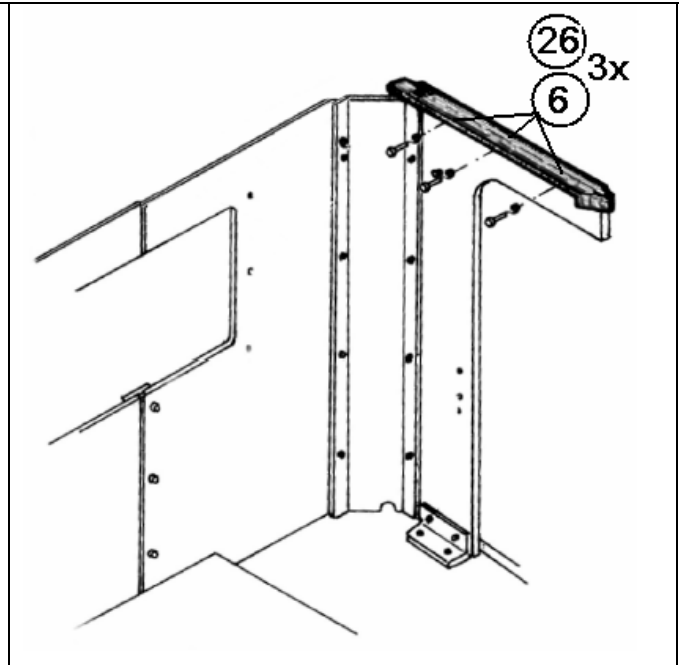
	<p><b>IMPORTANT</b></p> <p>Before installation, pull out the side lamps' electrical wiring through the holes in items #802 and #803, accordingly.</p>
---	---

### 5.8.2 Installation Instructions

1. Raise overlap #802 in to position as shown in Figure 5-33.
2. Pull the overhead light wires through the corresponding hole in overlap #802. Ensure that the wires remain accessible for reattachment of the interior lights at a later time.
3. Start the fasteners in the lower three holes. Thread them in only enough to retain #801 on the side armor panel. Do not tighten the fasteners at this time.
4. Repeat the above three steps on the left side with overlap #803.



**Figure 5-33. Roof Kit Installation-  
RH Corner (1 of 10).**



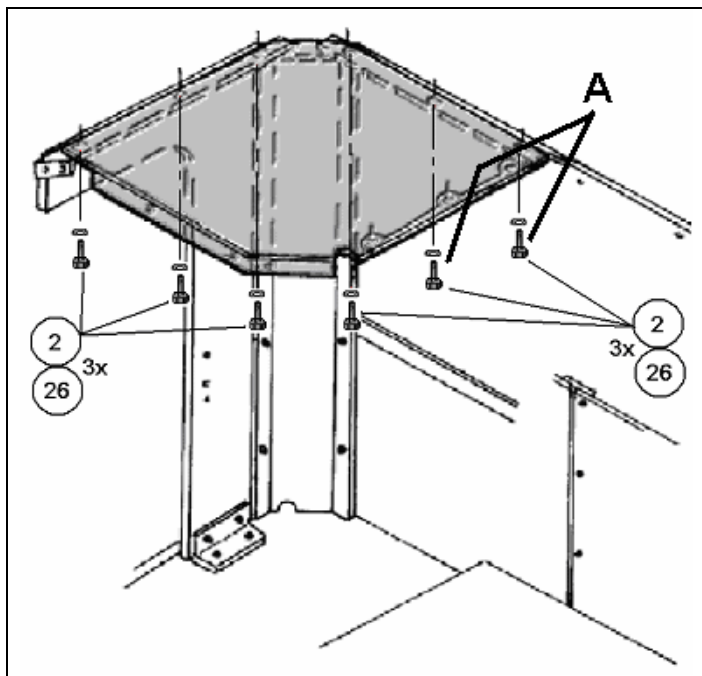
**Figure 5-34. Roof Kit Installation-  
LH Corner (2 of 10).**

5. Install brackets #802 and #803 in the locations shown in Figures 5-33 and 5-34. Raise roof panel #818 into position on the right side of the cab ceiling (reference Figure 5-35). Rest the outboard side of the panel on top of the upper edge of overlap #802. Temporarily support the inboard side of the roof panel with the telescopic roof support assembly, #008. Install only the outboard fasteners connecting the roof panel #818 to the side overlap #802.
6. Raise the left side roof panel #817 into position on the left side of the cab ceiling (reference Figure 5-36). Rest the outboard side of the panel on top of the upper edge of overlap #802 (reference Figure 5-36). Install the outboard fasteners connecting the roof panel #817 to corner overlap #803. Also, install fasteners connecting roof panel #817 to roof panel #818.

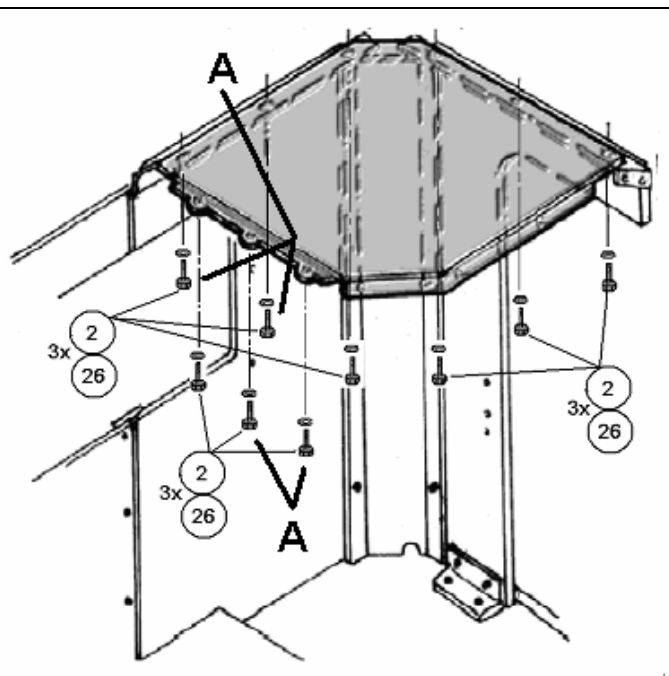


**CAUTION**

Use the supplied Telescopic Stand #008 to support the roof during installation.



**Figure 5-35. Roof Kit Installation –  
Right Rear (3 of 10).**

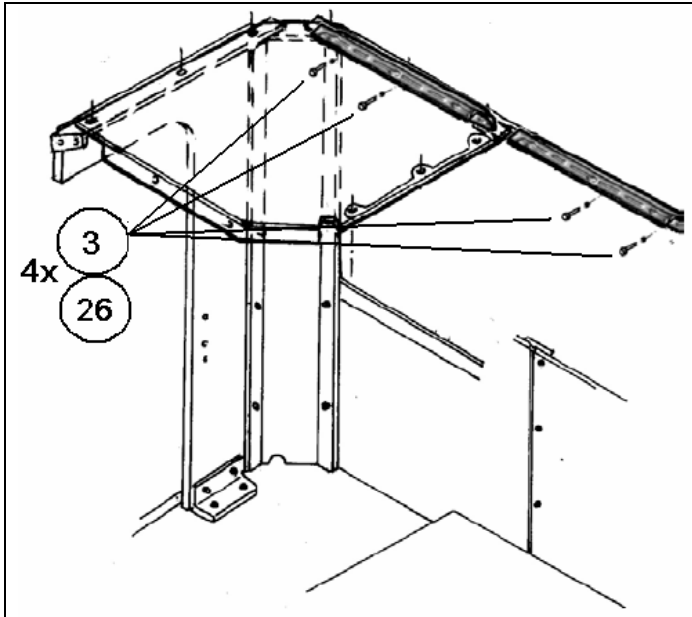


**Figure 5-36. Roof Kit Installation –  
Left Rear (4 of 10).**

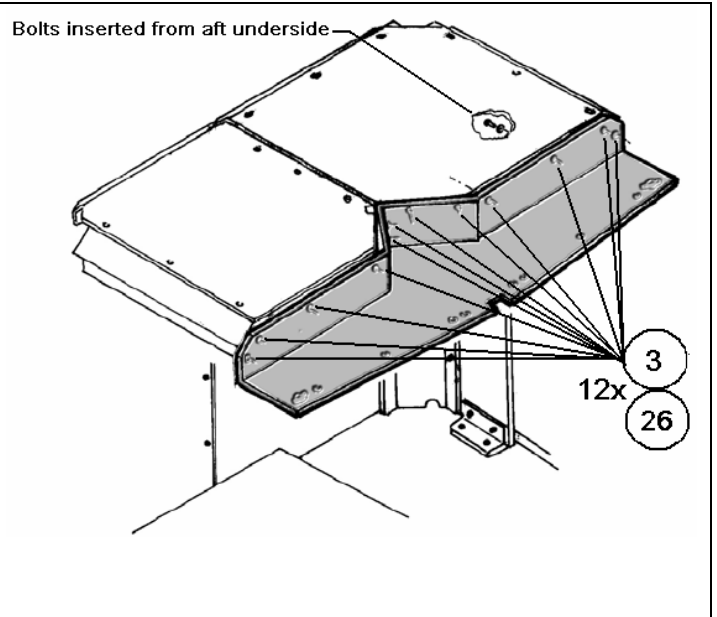
**Note:** For M915-A2 models, the fasteners indicated by an “A” in Figures 5-35 and 5-36 will be used for the installation of the Air Conditioner bracketry. The fasteners should not receive locking compound at this time, and may be left out until used for the installation of the Air Conditioner described in Manual RD-2-4617-0.

7. Raise overlap #828 into position between the aft wall and the right side roof panel. Install fasteners as indicated in Figures 5-35 and 5-37 to connect the overlap to the roof panel and the rear wall panel (reference 5-37). Repeat for the left side with overlap #829.
8. Raise the front roof panel, #804 into position as shown in Figure 5-38. Install fasteners connecting the front roof panel to the rear roof panels and side overlaps.

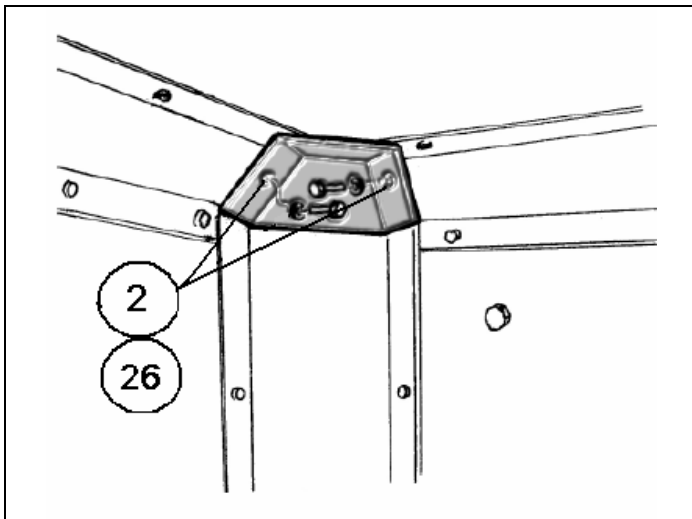




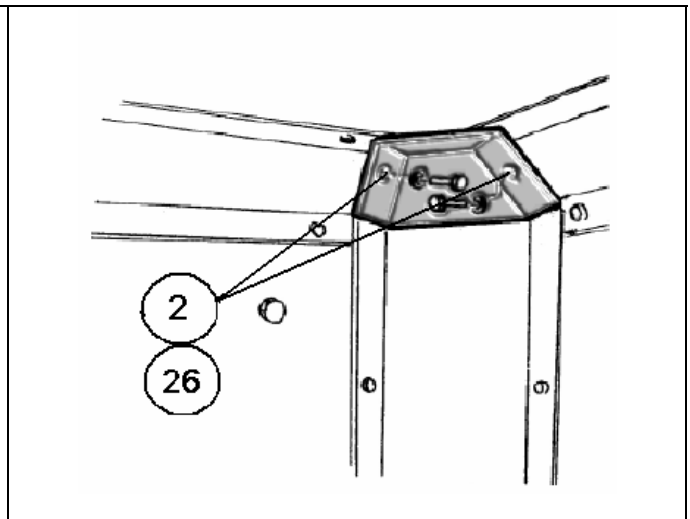
**Figure 5-37. Roof Kit Installation – Upper Aft Corner (5 of 10).**



**Figure 5-38. Roof Kit Installation – Forward Section (6 of 10).**



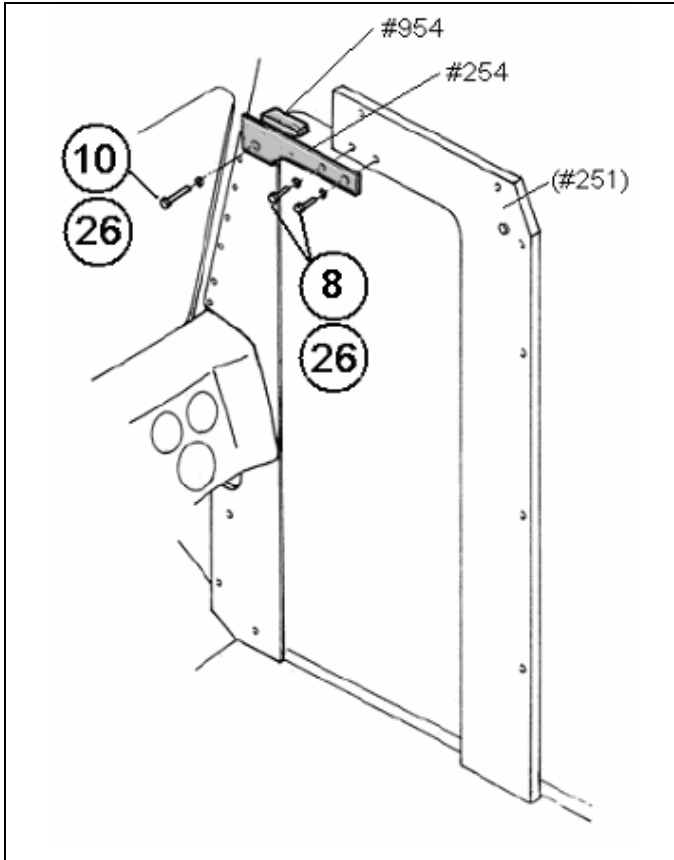
**Figure 5-39. Roof Kit Installation - Left Rear Corner (7 of 10).**



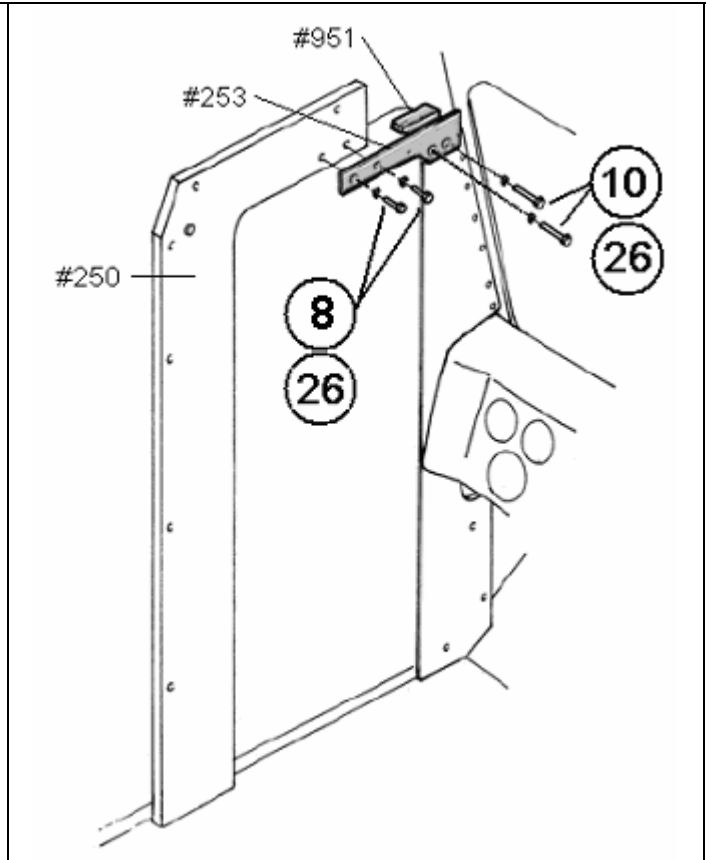
**Figure 5-40. Roof Kit Installation - Right rear Corner (8 of 10).**

9. Install the rear roof corners # 801 in each of the aft corners as indicated in Figures 5-39 and 5-40.
10. Position spacer #954 against the A-Pillar armor panel #251. Place the top A-pillar plate #254 on top of the spacer. Insert the forward fastener through the forward hole in #954, through the large-diameter hole in the spacer #954 and engage with the uppermost threaded insert in the A-pillar armor panel #251. Insert the two aft fasteners through the upper A-pillar plate and engage with the side armor panel #213 as shown in Figure 5-41.

11. Position spacer #951 against the A-Pillar armor panel #250. Place the top A-pillar plate #253 on top of the spacer. Insert the forward fasteners through the forward holes in #253, through the large-diameter hole in the spacer #951, and engage with the uppermost threaded inserts in the A-pillar armor panel #251. Insert the two aft fasteners through the upper A-pillar plate and engage with the side armor panel #250 as shown in Figure 5-42.

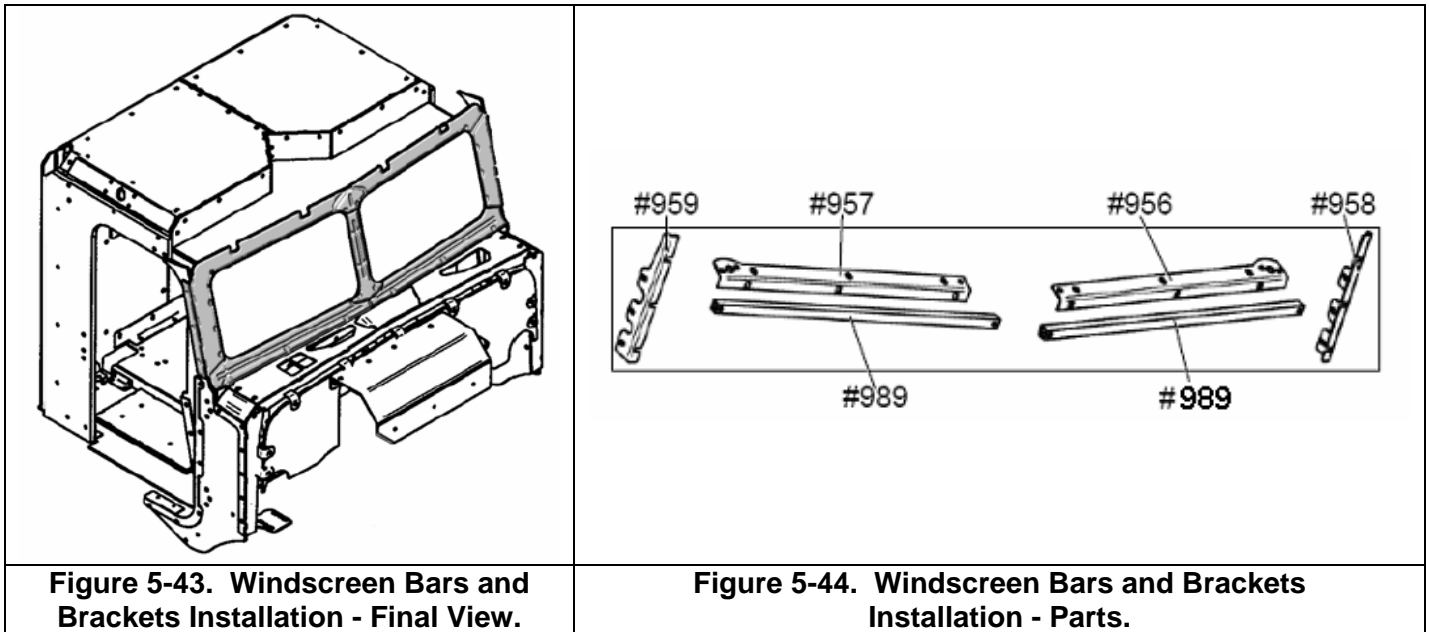


**Figure 5-41. Roof Kit Installation - RT Top A-Pillar (9 of 10).**



**Figure 5-42. Roof Kit Installation - LT Top A-Pillar (10 of 10).**

## 5.9 Windscreen Bars and Brackets Installation

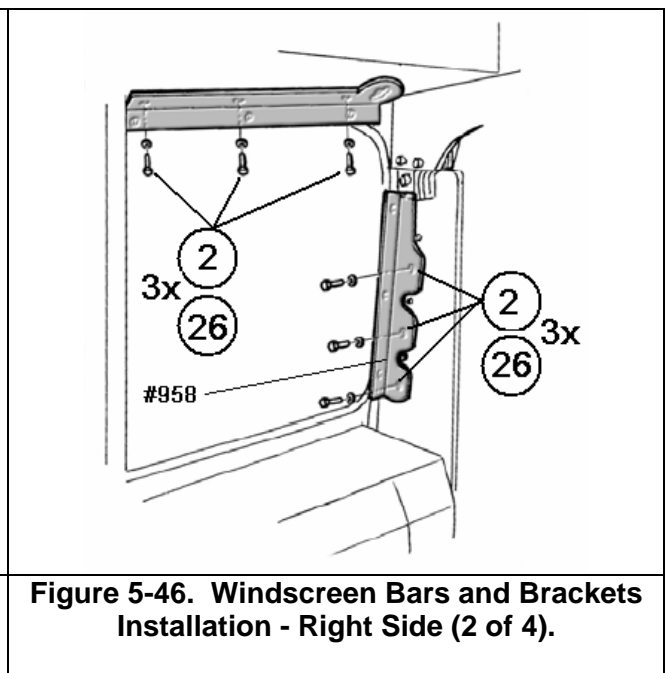
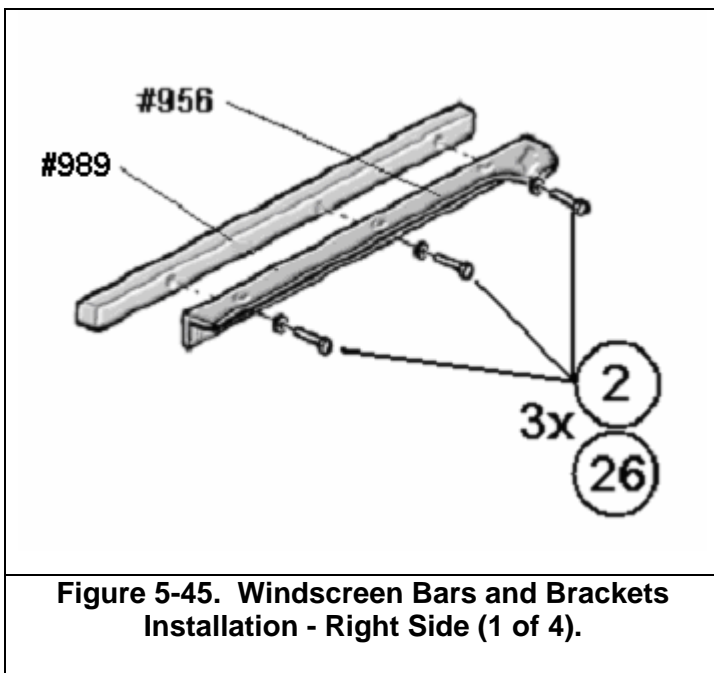


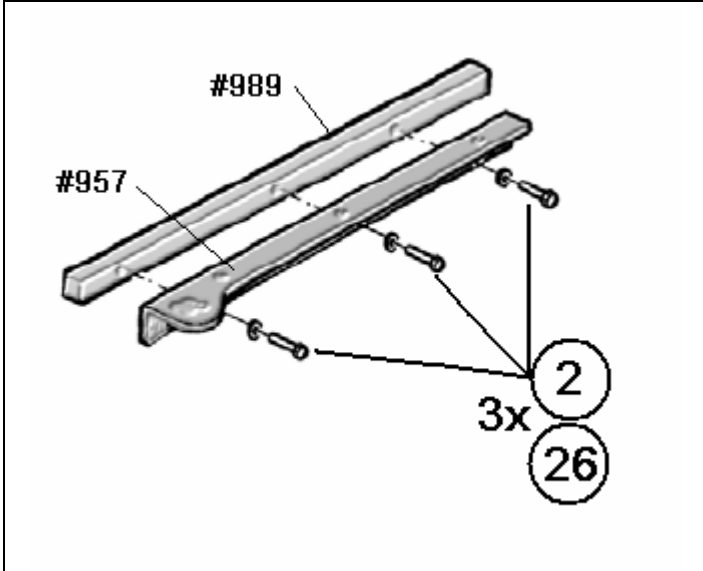
### 5.9.1 Parts, Fasteners, Special Tools, and Materials

Parts (see Figure 5-44)				
Part No.	Alternate Part No.	Description	Find No. in Procedure	Quantity
0257020956-00		Bracket, frame front window	#956	1
0257020957-00		Bracket, frame front window	#957	1
0257020958-00		Bracket, frame front window	#958	1
0257020959-00		Bracket, frame front window	#959	1
0257020989-00		Support windscreen	#989	2
Fasteners:				
Find No. (Table 3-5)	Description	Size	Quantity	
2	Bolt	5/16" x 3/4" NC	18	
26	Flat washer	5/16" x 21 x 3	18	
Special Tools/ Materials				
Description:		Vendor/Part-Number:		
None				

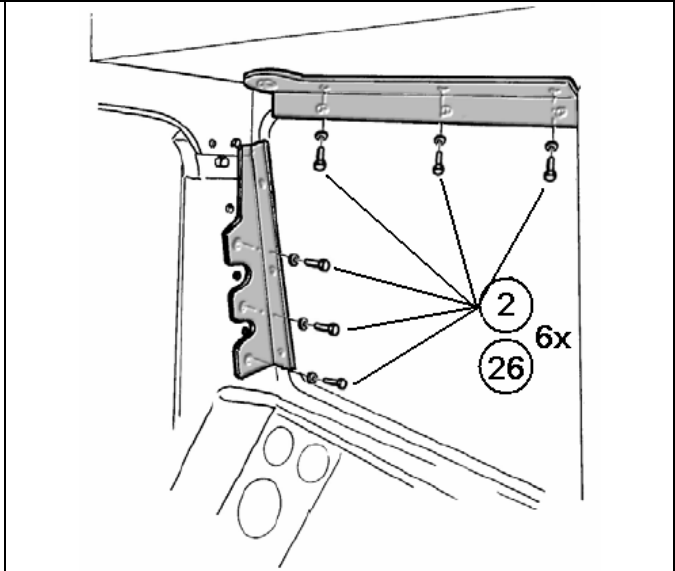
### 5.9.2 Installation Instructions

12. Assemble the right-side windscreen bar and bracket, components #956 and #989 per Figure 5-45.
13. Position the assembly over the windscreen opening as shown in figure 5-46. Attach to the front roof armor as indicated.
14. Install the side bracket #958 as shown in Figure 5-46.
15. Leave fasteners loose at this time to facilitate alignment with the windscreen.
16. Repeat Steps 1 through 4 above for the left side using Figures 5-47 and 5-58 for reference.





**Figure 5-47. Windscreen Bars and Brackets Installation - Left Side (3 of 4).**



**Figure 5-48. Windscreen Bars and Brackets Installation - Left Side (4 of 4).**

## 5.10 Firewall Kit Installation

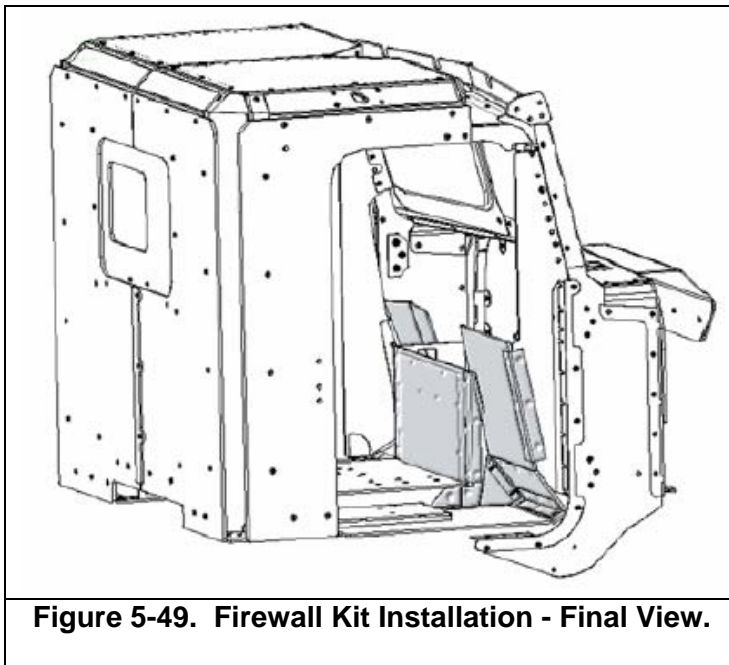


Figure 5-49. Firewall Kit Installation - Final View.

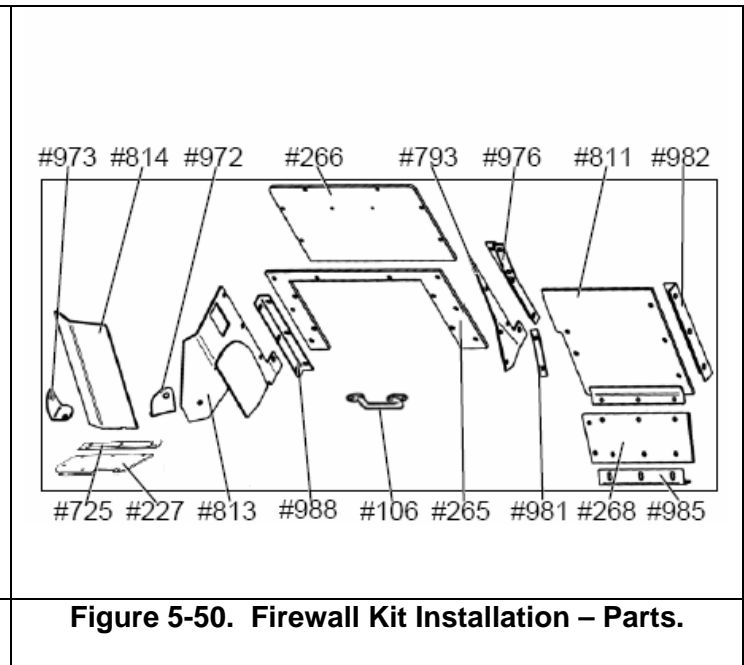


Figure 5-50. Firewall Kit Installation – Parts.

### 5.10.1 Parts, Fasteners, Special Tools, and Materials

Parts (see Figure 5-50)				
Part No.	Alternate Part No.	Description	Find No. in Procedure	Quantity
5340000106-00	190810263	Emergency Exit Handle	#106	1
0257122227-00		Floor LH Toeboard	#227	1
0257022265-00	0257027365-00	Internal Firewall Center	#265	1
0257022266-00	0257027366-00	Internal Firewall Service Hatch	#266	1
0257022268-00	0257027368-00	Internal Firewall RH 2	#268	1
0257127725-00		Overlap Driver	#725	1
0257027793-00		Interior Firewall RH of Central Wall	#793	1
0257020811-00	0257020862-00	RH Internal Firewall	#811	1
0257020813-00		Interior Firewall Driver Side	#813	1
0257020814-00		Interior A Pillar Bottom	#814	1
0257020972-00		Bracket Driver Floor to Firewall Internal	#972	1
0257120973-00		Bracket Driver Floor to Side Internal	#973	1
0257120976-00		Bracket, Center Firewall to RH Firewall	#976	1
0257020981-00		Connection Middle Floor to Back Wall 2	#981	1
0257020982-00		Connection Firewall to Internal Side RH	#982	1
0257120985-00		Connection RH Floor to Firewall Internal	#985	1
0257020988-00		Connection Internal Firewall Driver Side	#988	1

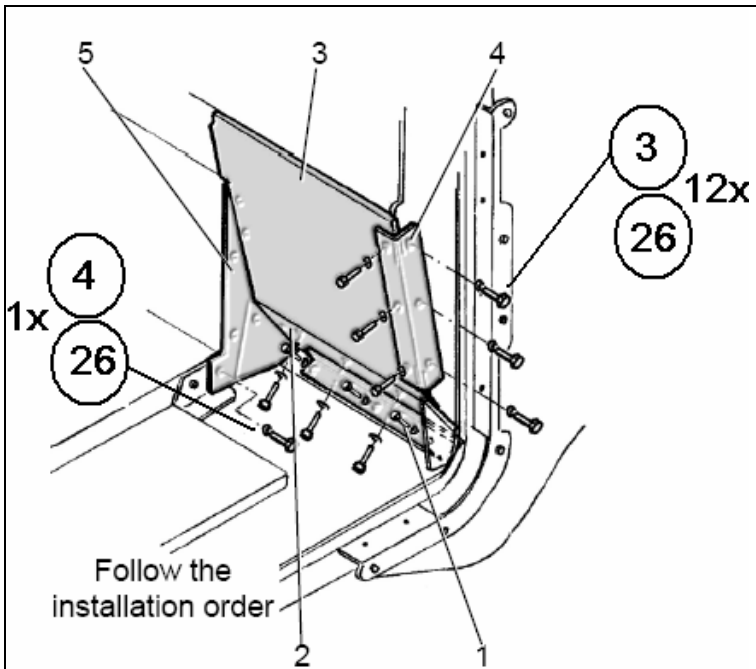
<b>Fasteners:</b>			
<b>Find No. (Table 3-5)</b>	<b>Description</b>	<b>Size</b>	<b>Quantity</b>
3	Bolt	5/16" x 1" NC	41
4	Bolt	5/16" x 1 1/4" NC	8
26	Flat washer	5/16" x 21 x 3	48
68	Bolt	1/4" x 1" NC	2
36	Nut	1/4" NC	2

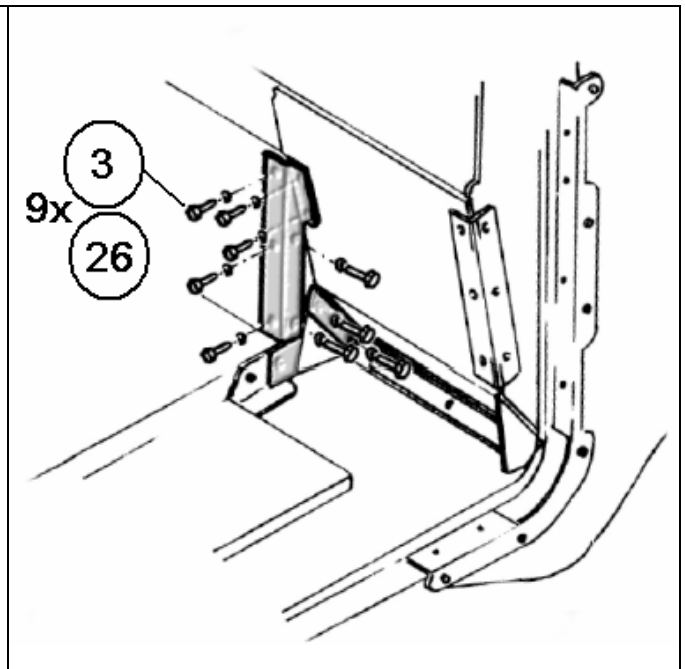
<b>Special Tools/ Materials</b>	
<b>Description:</b>	<b>Vendor/Part-Number:</b>
None	

### 5.10.2 Installation Instructions

1. Install components in the order defined in Figure 5-51. It is essential that the fasteners are not tightened until the assembly is complete, since the fasteners must be loose to allow alignment of the components.



**Figure 5-51. Firewall Kit Installation (1 of 4).**



**Figure 5-52. Firewall Kit Installation (2 of 4).**

2. Continue installation of components in sequence with Figures 5-52 through 5-54.
3. Note: Handle #106 must be installed to panel #266 prior to installation of panel #266 on the vehicle.

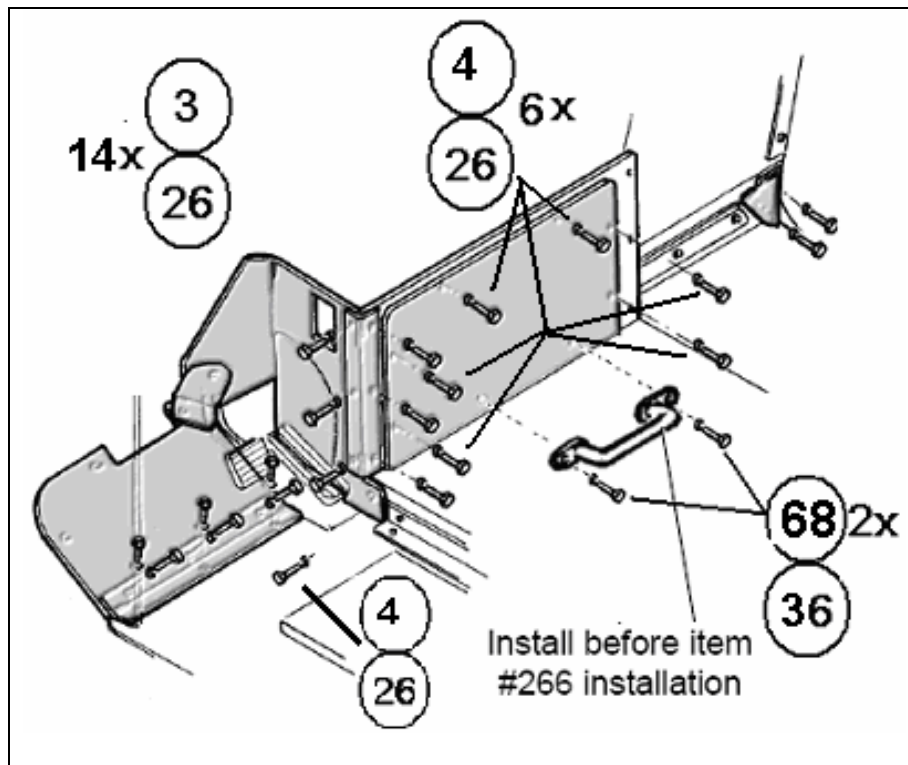


Figure 5-53. Firewall Kit Installation (3 of 4).

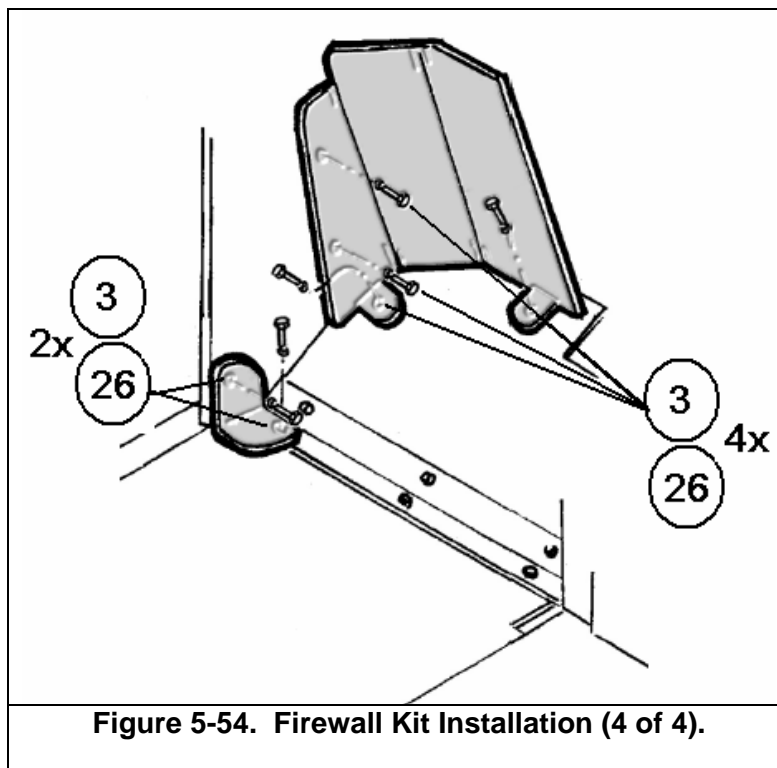
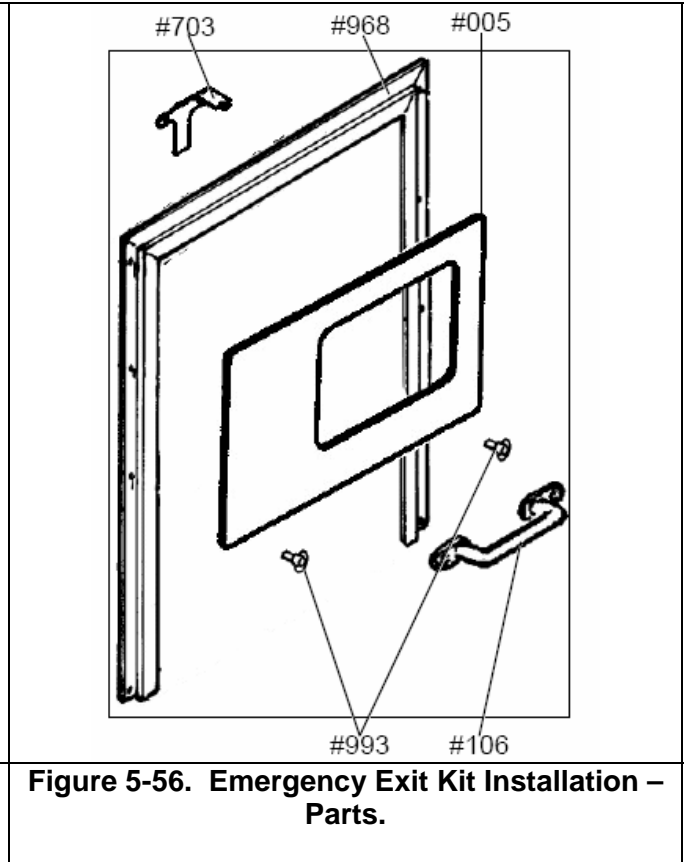
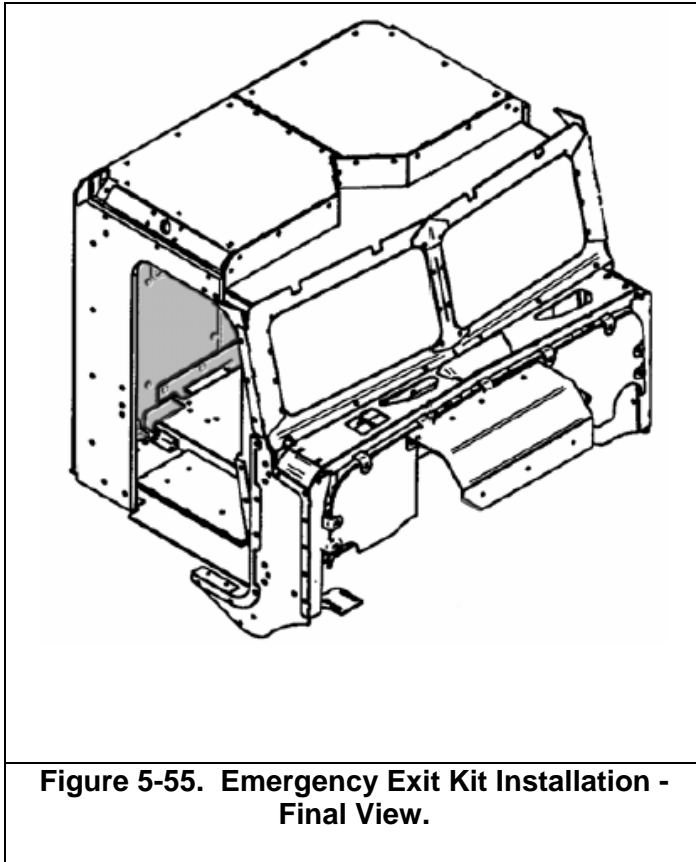


Figure 5-54. Firewall Kit Installation (4 of 4).




## 5.11 Emergency Exit Installation



### 5.11.1 Parts, Fasteners, Special Tools, and Materials

Parts (see Figure 5-56)				
Part No.	Alternate Part No.	Description	Find No. in Procedure	Quantity
0257060005-00	0257060065-00	Rear Window Assy	#005	1
5340000106-00	190810263	Emergency Exit Handle	#106	1
0257017703-00		Rear Roof Overlap	#703	1
0257060968-00		Frame, Rear Window	#968	1
0257120993-00		Rear Window Stopper	#993	2
5540000028-00		Rubber Profile MF-18	#028	0.8 m

<b>Fasteners:</b>			
<b>Find No. (Table 3-5)</b>	<b>Description</b>	<b>Size</b>	<b>Quantity</b>
3	Bolt	5/16" x 1" NC	8
26	Flat washer	5/16" x 21 x 2.2	11
2	Bolt	5/16" x 3/4" NC	1
16	Bolt, Button Head	1/4" x 3/4" NC	2
4	Bolt	5/16" x 1-1/4" NC	2
<b>Special Tools/ Materials</b>			
<b>Description:</b>		<b>Vendor/Part-Number:</b>	
None			

	<p><b>IMPORTANT</b>          Do not scratch the Emergency Exit window. Only water and a soft cloth should be used while cleaning the window.</p>
---	--

### 5.11.2 Installation Instructions

**Note:** For M915-A2 models, the fasteners indicated by an “A” in Figure 5-58a will be used for the installation of the Air Conditioner Hoses. The fasteners should not receive locking compound at this time, and may be left out until used for the installation of the Air Conditioner described in Manual RD-2-4617-0.

1. Attach rubber profile #028 to the edge of the frame #968 as shown in Figure 5-57.
2. Attach handle #106 to window panel #005.
3. Place the window panel #005 in position against the rear armor panels.
4. Set the frame #968 over the over the window panel and align with the corresponding holes in the rear armor panels.
5. Install the fasteners as indicated in Figure 5-58a. Tighten all fasteners except the two lower right-side bolts. These two bolts will be used at a later point to secure the electronics panel to the back wall.
6. Check operation of the window panel. The panel must be free to move up or down with reasonable force applied by one hand. If panel movement is difficult, check for faults and correct as necessary. If required, the frame (#968) may be shimmed away from the rear armor panels by placing washers between the frame and the rear armor panels at each fastener location. If shims are applied, ensure that bolt thread engagement is not reduced below full engagement with the nuts in the rear armor panels.
7. Raise the window panel #005 to the “closed” position and secure with pins, #993.
8. Install the ECM panel as shown in Figure 5-58b. This requires that two holes be match-drilled through the aluminum back panel to the lower right mounting holes in the frame

#968. Note: An additional mount panel is provided for the left side, aft wall for use in M916-A1 and M915-A2 installations. Refer to Section 7.7 for associated documentation.

9. Install the rear roof overlap #903 per Figure 5-59.
10. If the OEM-installed rear window screen has not yet been removed from the vehicle, do so at this time. This is essential to ensure that the emergency egress path is not blocked.



**WARNING**

Check operation of the emergency window panel. The panel must be readily lowered or raised by one person. When lowered, the panel must allow full access to the OEM rear window for emergency egress.

Attach Rubber  
Profile MF-18 (#028)

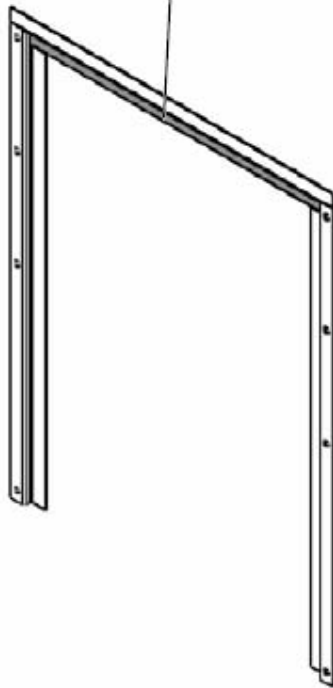


Figure 5-57. Emergency Exit Kit Installation  
(1 of 4).

Apply shims (8 each, item 26)  
if required.

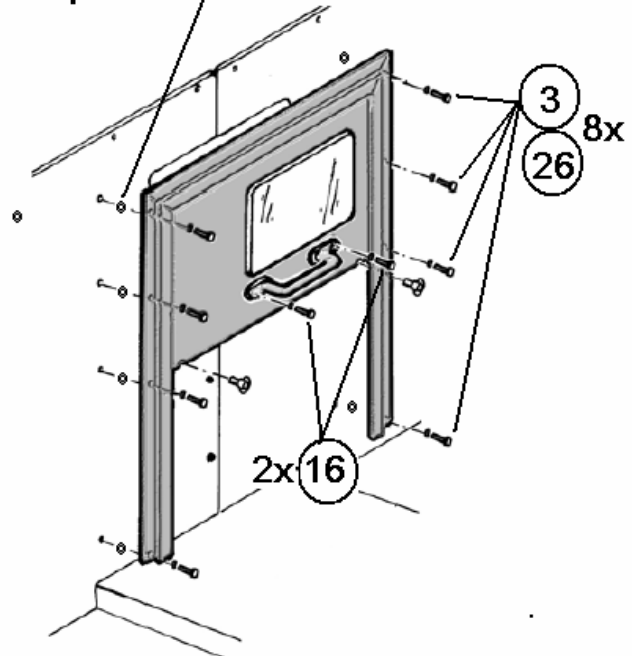
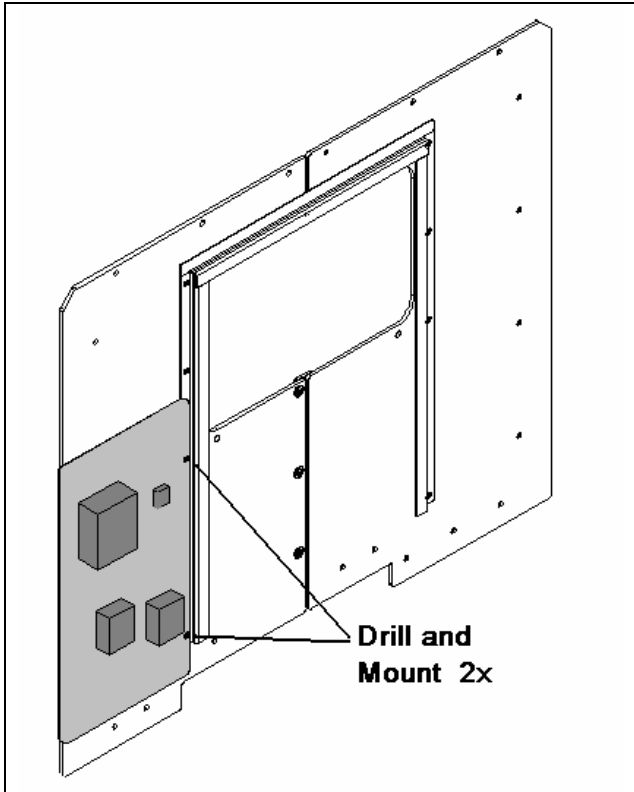
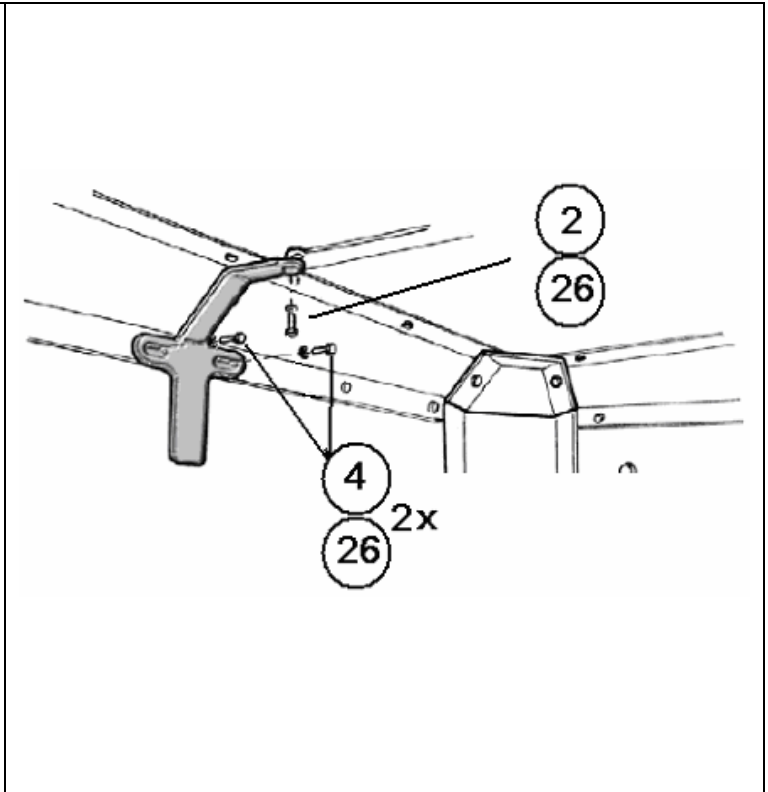


Figure 5-58a. Emergency Exit Kit Installation  
(2 of 4).

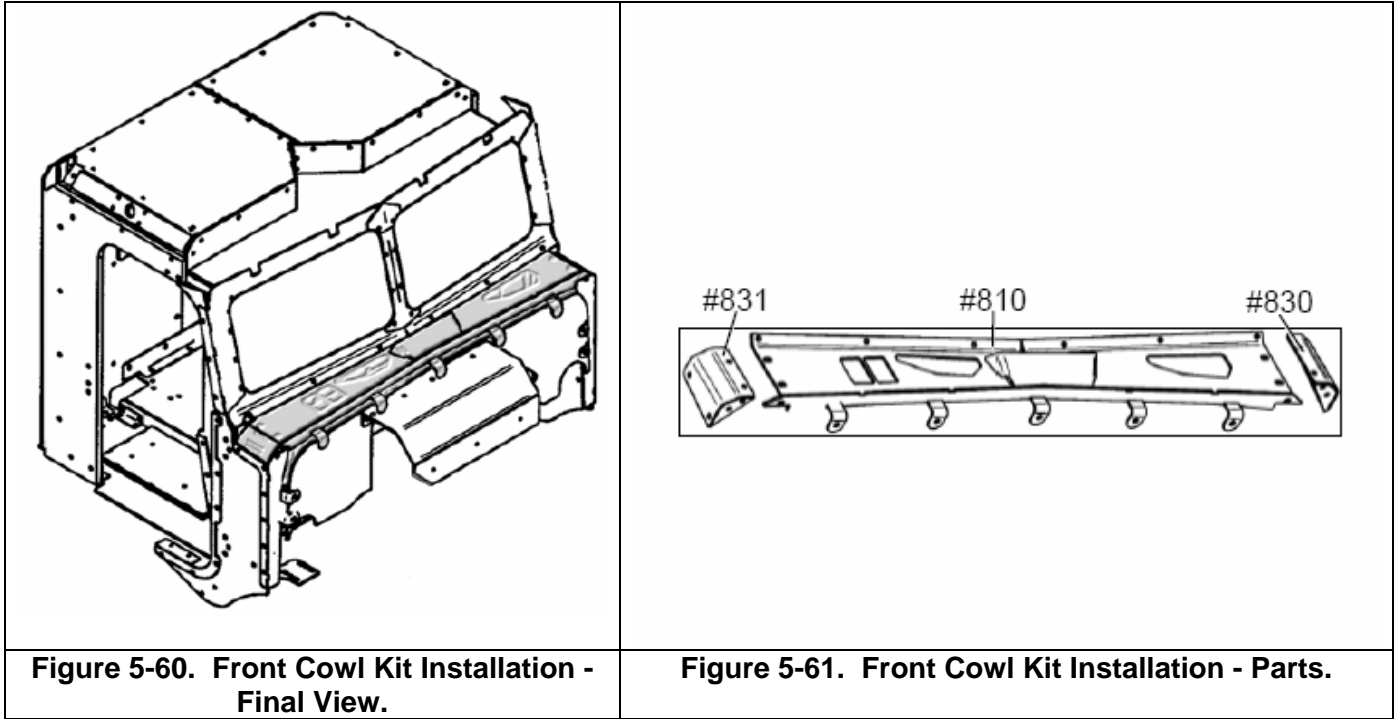


**Figure 5-58b. Emergency Exit Kit Installation - ECM mounting (3 of 4).**



**Figure 5-59. Emergency Exit Kit Installation (4 of 4).**

## 5.12 Front Cowl Installation

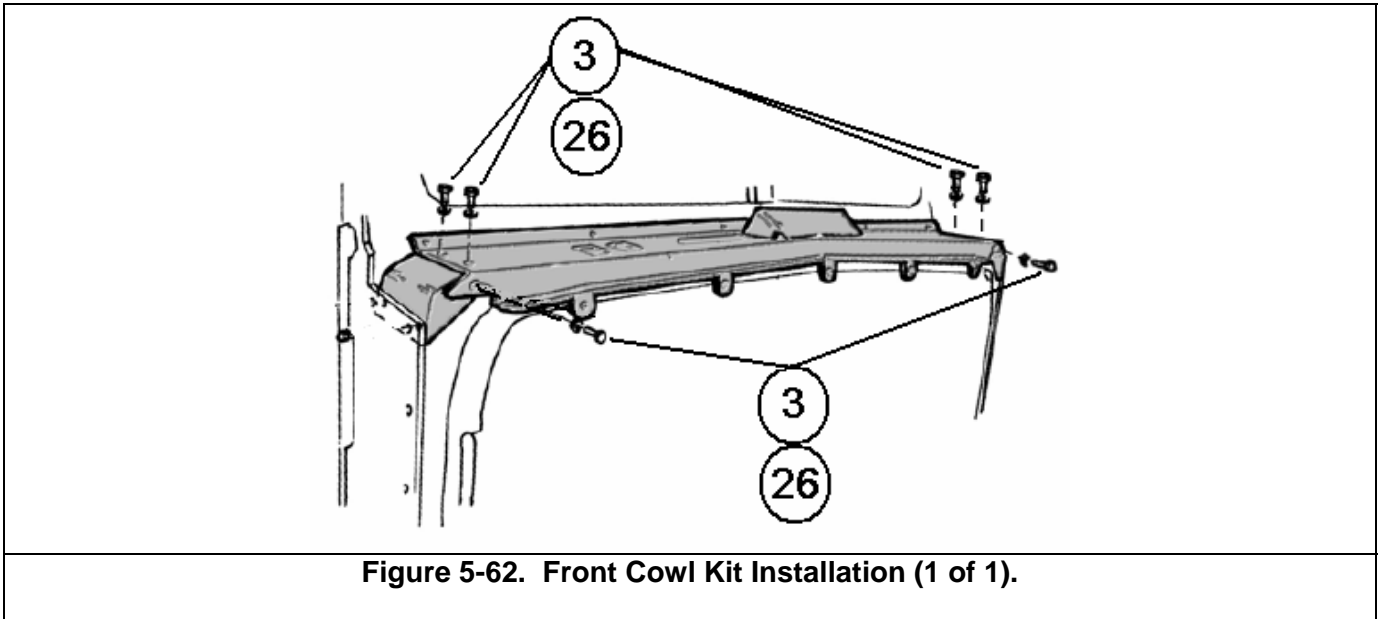


### 5.12.1 Parts, Fasteners, Special Tools, and Materials

<b>Parts (see Figure 5-62)</b>				
Part No.	Alternate Part No.	Description	Find No. in Procedure	Quantity
0257020810-00		Center, Cowl Armor,	#810	1
0257020830-00		Corner, Cowl Armor	#830	1
0257020831-00		Corner, Cowl Armor	#831	1
<b>Fasteners:</b>				
Find No. (Table 3-5)	Description	Size	Quantity	
3	Bolt	5/16" x 1" NC	6	
26	Flat washer	5/16" x 21 x 3	6	
<b>Special Tools/ Materials</b>				
<b>Description:</b>		<b>Vendor/Part-Number:</b>		
None				

### 5.12.2 Installation Instructions

1. Position the corner brackets #830 and #831 on part #810 as indicated in Figures 5-60 and 5-62.
2. Secure with fasteners indicated.
3. Lift the assembly onto the vehicle, directly in front of the windshield opening. Note that it will not be secured to the vehicle at this time.



### 5.13 RH Cowl (A-Pillar) Kit Installation

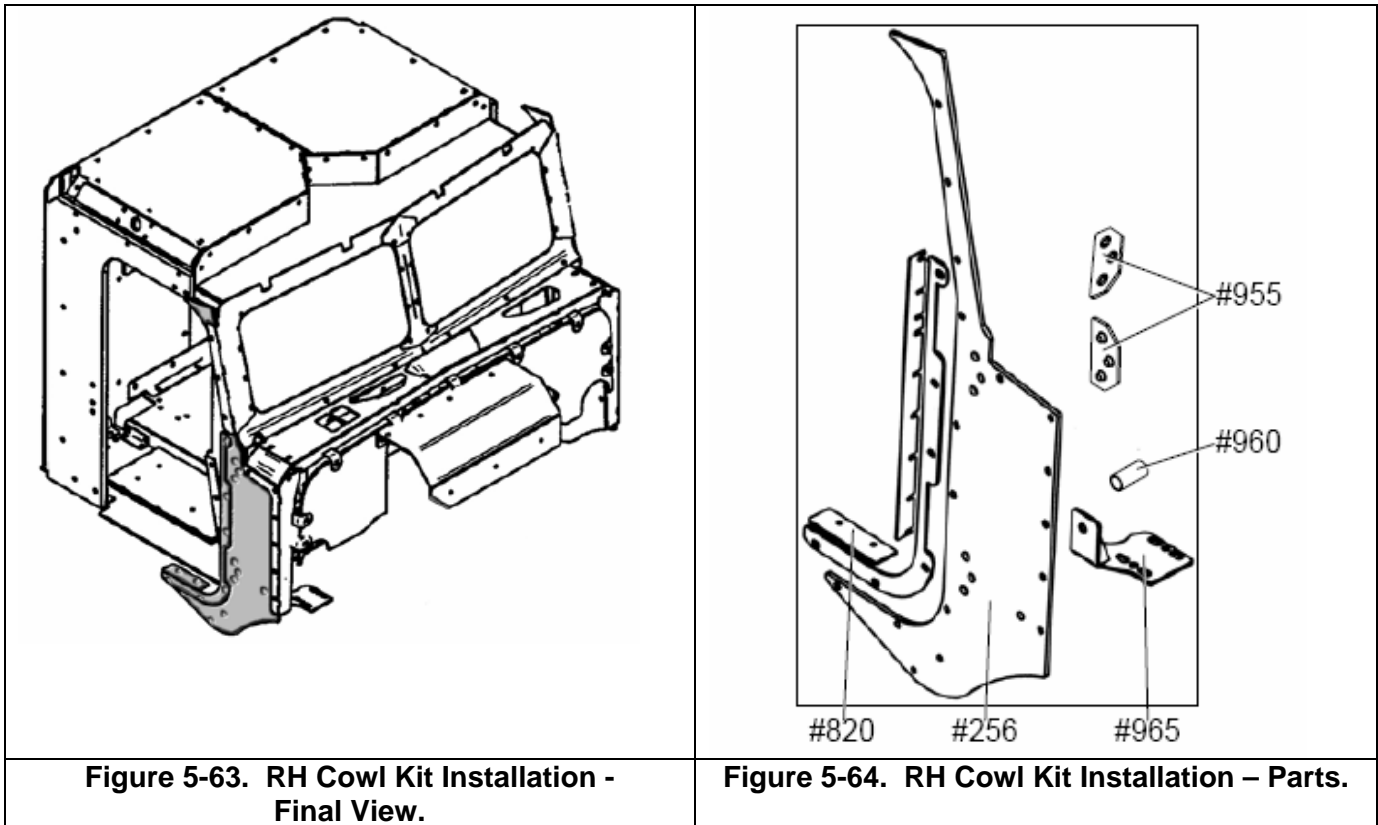



Figure 5-63. RH Cowl Kit Installation - Final View.


Figure 5-64. RH Cowl Kit Installation – Parts.

#### 5.13.1 Parts, Fasteners, Special Tools, and Materials

Parts (see Figure 5-64)				
Part No.	Alternate Part No.	Description	Find No. in Procedure	Quantity
0257032256-00	0257032156-00	RH A -Pillar External	#256	1
0257030820-00		RH A -Pillar External Overlap	#820	1
0257030955-00		Spacer, Threaded, Hinge Side	#955	2
0257030960-00		Spacer External Side	#960	1
0257030965-00		Bracket Engine Cover LH	#965	1

<b>Fasteners:</b>			
<b>Find No. (Table 3.5)</b>	<b>Description</b>	<b>Size</b>	<b>Quantity</b>
2	Bolt	5/16" x 3/4" NC	6
27	Flat washer	5/16" x 30 x 3	8
17	Bolt	1/4" x 1-1/4" NC	7
33	Flat washer	1/4" x 20 x 2	7
13	Bolt	3/8" x 3-1/2" NC	1
30	Flat washer	3/8" x 30 x 3	2
38	Nut	3/8" NC	1
12	Bolt Counter Sunk	5/16" x 1"	2
26	Washer, flat	5/16	2
37	Nut	5/16	2
19	Bolt	7/16" x 1" NF	2
31	Washer	7/16" x 23 x 3	2
4	Bolt	5/16" x 1 1/4" NC	2
<b>Special Tools/ Materials</b>			
<b>Description:</b>		<b>Vendor/Part-Number:</b>	
None			

	<p><b>IMPORTANT</b>                  Before installation of armor panel, item #256, install two of the threaded spacers #955 in the inboard side of #256</p>
---	--

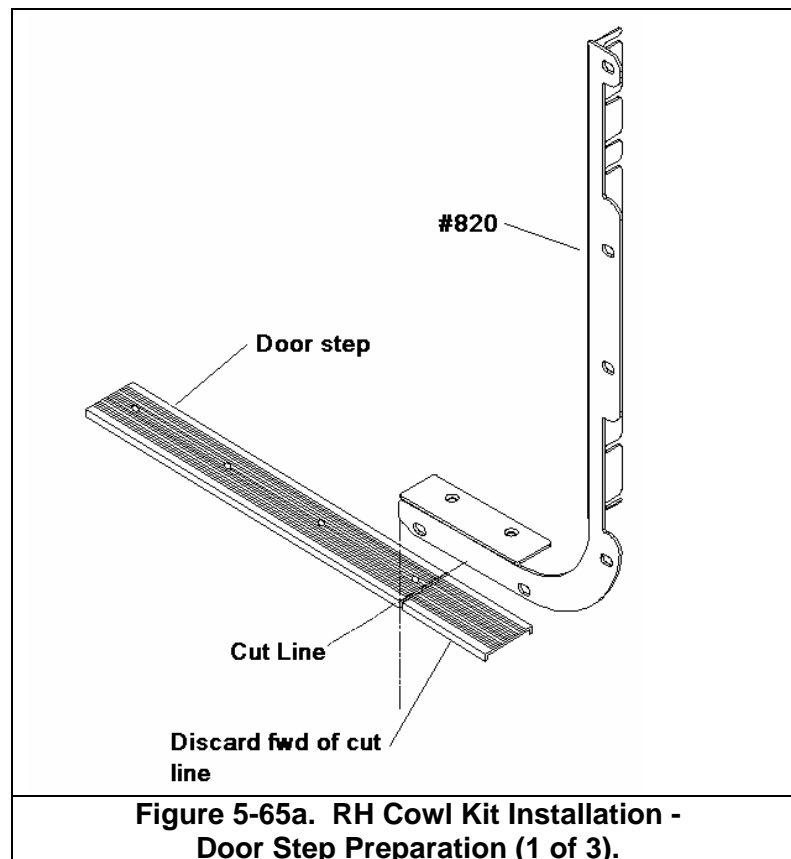
	<p><b>CAUTION</b>                  The composite panels are direction-sensitive and must be installed with the "strike face" facing outboard on the vehicle. Ensure that the correct part number is used in the intended location and that orientation places the strike face toward the outboard side of the vehicle.</p>
---	--

### 5.13.2 Installation Instructions

1. Place Bracket #820 in position against the A-pillar. Rest the step against the OEM corrugated door step that is mounted on the bottom of the cab door frame. Mark the corrugated door step at the point corresponding to the back edge of #820 as shown in Figure 5-65a. Remove bracket #820. Cut the OEM corrugated door step at the line just marked. Remove and discard the forward portion of the corrugated door step.
2. Place brackets #995 on the back face of the external A-pillar panel and retain with one bolt each as shown in Figure 5-65b. The brackets should be positioned with the protruding flanges into the A-pillar panel.
3. Secure the A-pillar overlap #820 to the A-pillar panel #256 using bolts and washers (2, 27).



4. Install bracket #965 as indicated in Figure 5-65b. The bracket is mounted between the OEM bumper and the OEM bumper mount.
5. Place a bolt (13) with a washer (30) through the appropriate hole in the external A-pillar panel #256. Place the spacer #960 on the bolt against the back side of panel #255. Set the A-pillar panel in position against the side of the vehicle cab. The bushing #960 should pass through the 30-mm hole drilled in the side of the cab (reference Section 2). The bolt should pass through the corresponding hole in bracket #965. Secure the bolt with nut (38) and washer (30).
6. Install bolts and washers (2, 27) that interface with the cowl armor corners (installed in Section 5-12). Leave these bolts loose, as they must be removed and reinstalled in Step 5.15.
7. Install the bolts securing the overlap to the OEM hinge mount points on the A-pillar as shown in Figure 5-66.
8. All fasteners that have been installed to this point should still be loose to allow for positioning of the panel. Press the lower section of the A-pillar overlap firmly against the cab so that it is inboard and down it as far as possible against the lower edge of the door frame (reference Figure 5-66). Hold in this position and drill two 5/16-in. clearance holes through the lower door frame. Install bolts, washers (12, 33, 37), and tighten.



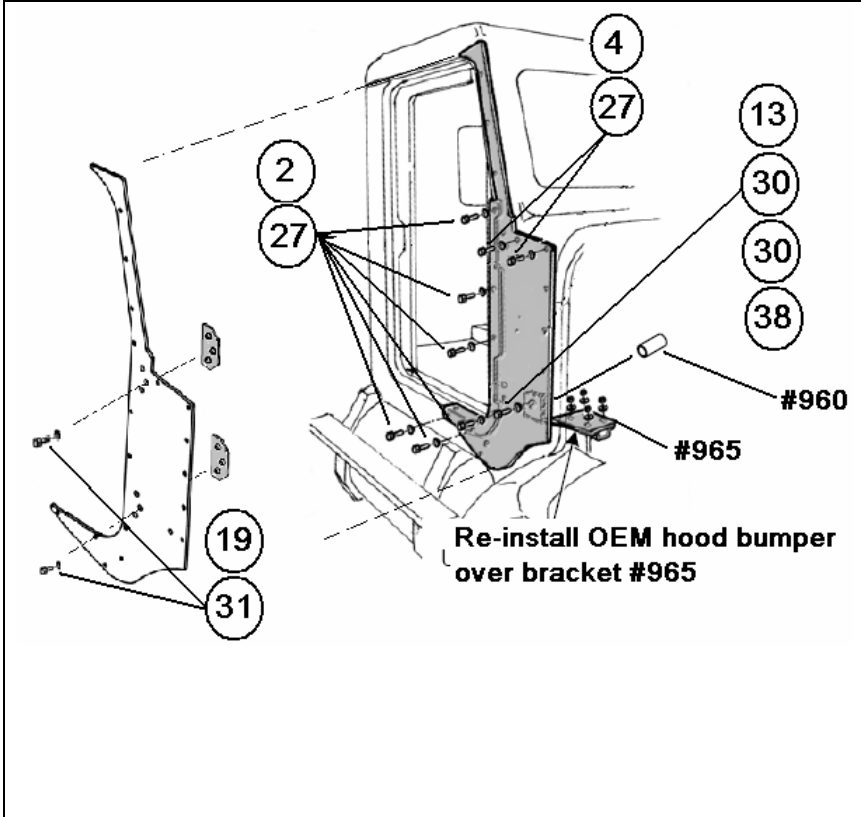


Figure 5-65b. RH Cowl Kit Installation  
(2 of 3).

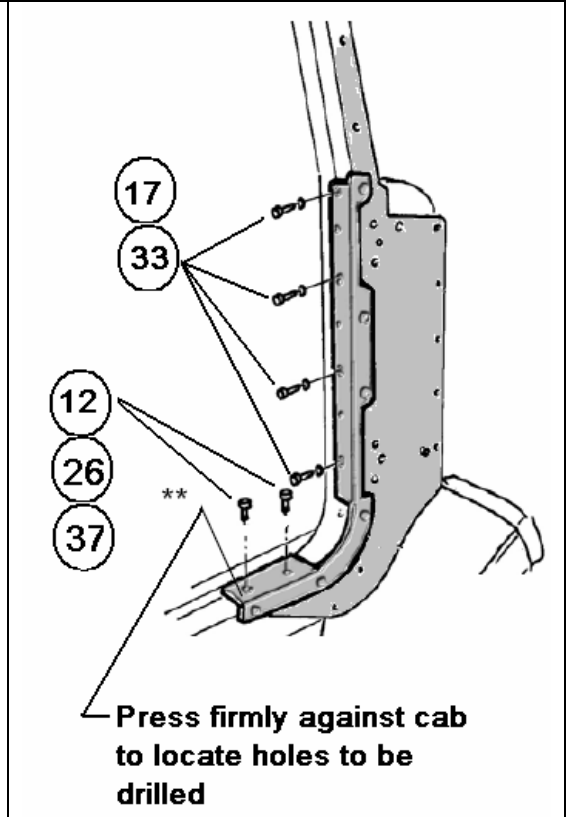


Figure 5-66. RH Cowl Kit Installation  
(3 of 3).

### 5.14 LH Cowl (A-Pillar) Kit Installation

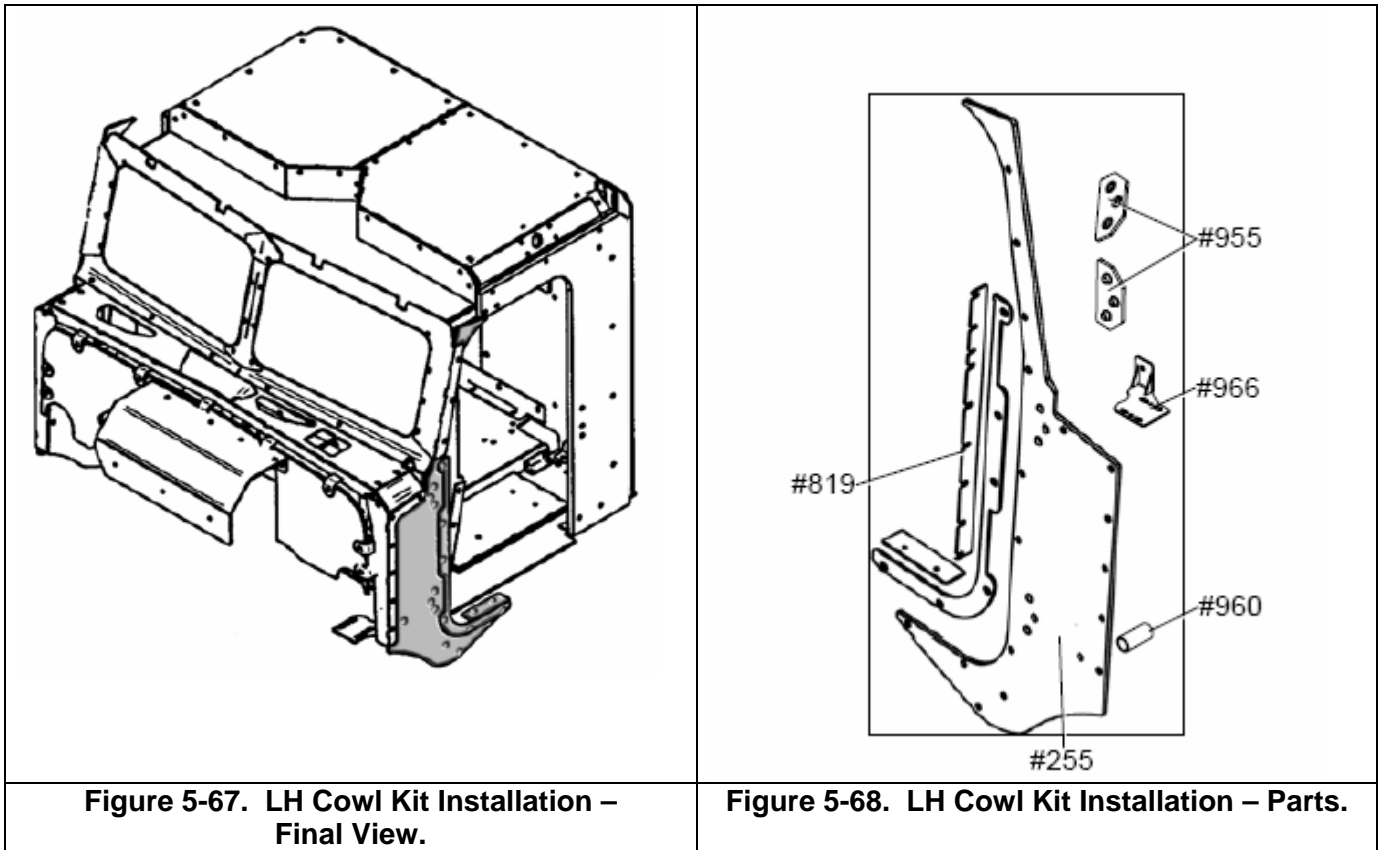



Figure 5-67. LH Cowl Kit Installation – Final View.


Figure 5-68. LH Cowl Kit Installation – Parts.

#### 5.14.1 Parts, Fasteners, Special Tools, and Materials

Parts (see Figure 5-68)				
Part No.	Alternate Part No.	Description	Find No. in Procedure	Quantity
0257032255-00	0257032155-00	LH A -Pillar External	#255	1
0257030819-00		LH A -Pillar External Overlap	#819	1
0257030960-00		Spacer External Side	#960	1
0257030966-00		Bracket Engine Cover RH	#966	1
0257030955-00		Spacer for Hinge Side	#955	2

<b>Fasteners:</b>			
<b>Find No. (Table 3-5)</b>	<b>Description</b>	<b>Size</b>	<b>Quantity</b>
2	Bolt	5/16" x 3/4" NC	6
27	Flat washer	5/16" x 30 x 3	8
17	Bolt	1/4" x 1-1/4" NC	7
33	Flat washer	1/4" x 20 x 2	7
13	Bolt	3/8" x 3-1/2" NC	1
30	Flat washer	3/8" x 30 x 3	2
38	Nut	3/8" NC	1
12	Bolt Counter Sunk	5/16" x 1"	2
26	Washer, flat	5/16	2
37	Nut	5/16	2
19	Bolt	7/16" x 1" NF	2
31	Washer	7/16" x 23 x 3	2
4	Bolt	5/16" x 1-1/4" NC	2
<b>Special Tools/ Materials</b>			
<b>Description:</b>		<b>Vendor/Part-Number:</b>	
None			

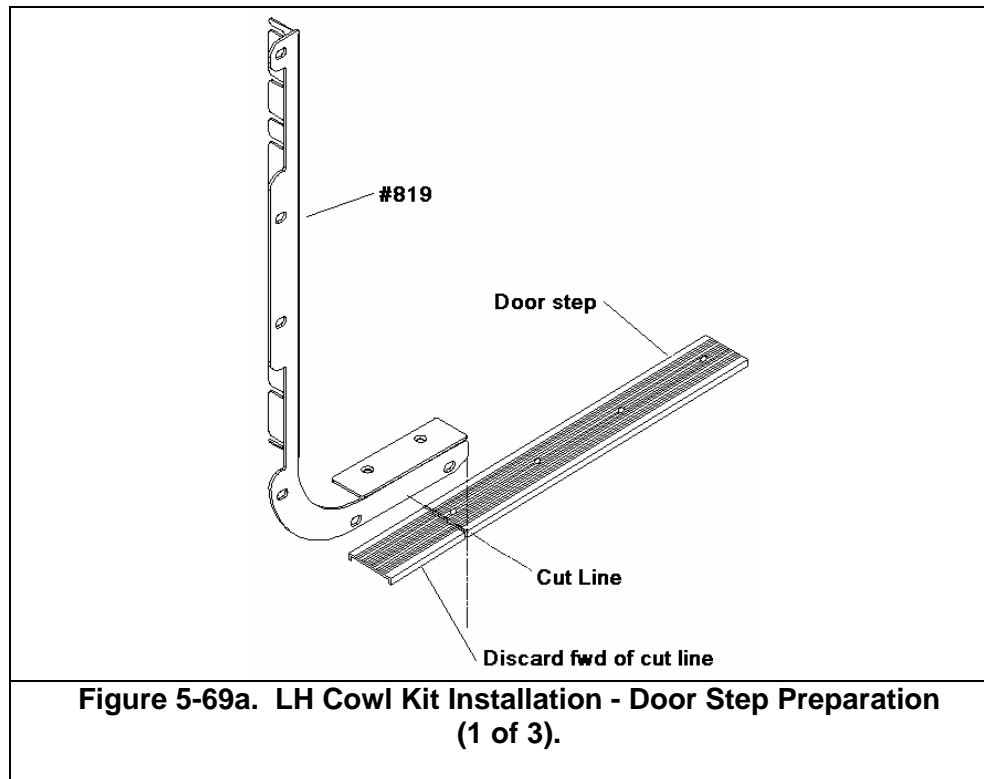
	<p><b>IMPORTANT</b>          Before installation of armor panel, item #255, install two of the threaded spacers #955 in the inboard side of #256.</p>
---	---

	<p><b>CAUTION</b>          The composite panels are direction-sensitive and must be installed with the “strike face” facing outboard on the vehicle. Ensure that the correct part number is used in the intended location and that orientation places the strike face toward the outboard side of the vehicle.</p>
---	--

### 5.14.2 Installation Instructions

1. Place Bracket #819 in position against the A-pillar. Rest the step against the OEM corrugated door step that is mounted on the bottom of the cab door frame. Mark the corrugated door step at the point corresponding to the back edge of #819 as shown in Figure 5-69a. Remove bracket #819. Cut the OEM corrugated door step at the line just marked. Remove and discard the forward portion of the corrugated door step.
2. Place brackets #995 on the back face of the external A-pillar panel and retain with one bolt each as shown in Figure 5-69. The brackets should be positioned with the protruding flanges into the A-pillar panel.
3. Secure the A-pillar overlap #819 to the a-pillar panel #255 using bolts and washers (2, 27).

4. Install bracket #966 as indicated in Figure 5-69b. The bracket is mounted between the OEM bumper and the OEM bumper mount.
5. Place a bolt (13) with a washer (30) through the appropriate hole in the external A-pillar panel #255. Place the spacer #960 on the bolt against the back side of panel #255. Set the A-pillar panel in position against the side of the vehicle cab. The bushing #960 should pass through the 30-mm hole drilled in the side of the cab (reference Section 2). The bolt should pass through the corresponding hole in bracket #966. Secure the bolt with nut (38) and washer (30).
6. Install bolts and washers (2, 27) that interface with the cowl armor corners (installed in Section 5-12). Leave these bolts loose, as they must be removed and reinstalled in Step 5-15.
7. Install bolts securing the overlap to the OEM hinge mount points on the A-pillar as shown in Figure 5-70.
8. All fasteners that have been installed to this point should still be loose to allow positioning of the panel. Press the lower section of the A-pillar overlap firmly against the cab so that it is inboard and down as far as possible against the lower edge of the door frame (reference Figure 5-70). Hold in this position and drill two 0.32-in.-diameter holes through the lower door frame. Install bolts, washers (12, 33, 37), and tighten.



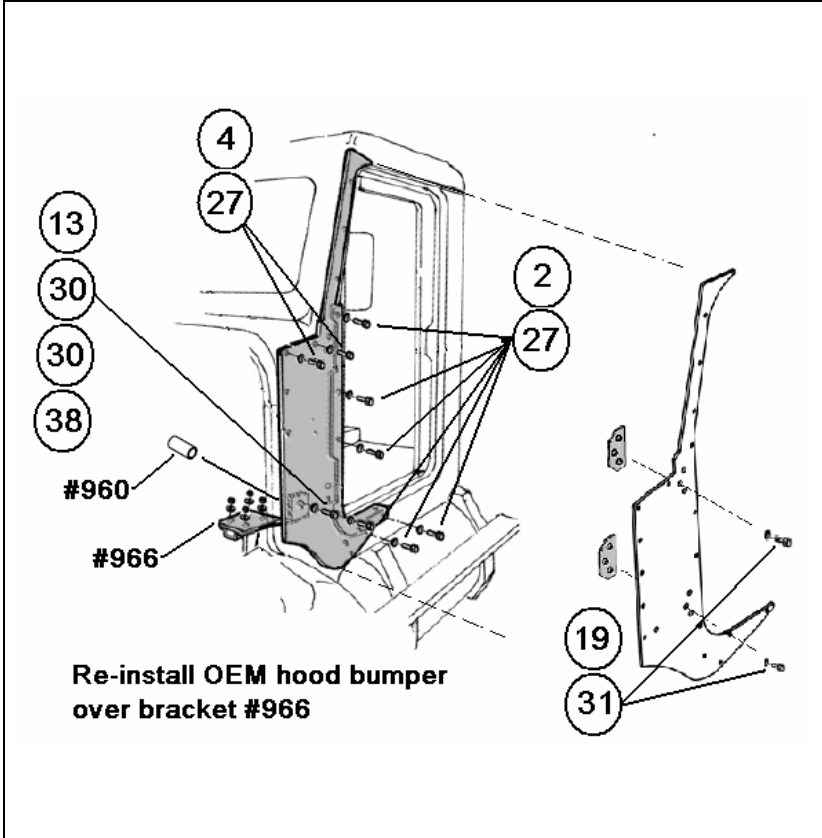


Figure 5-69b. LH Cowl Kit Installation  
 (2 of 3).

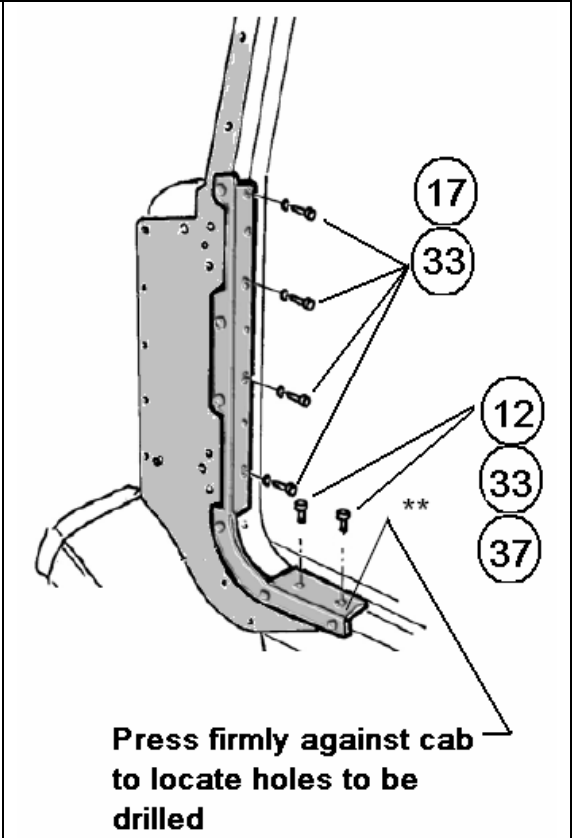


Figure 5-70. LH Cowl Kit Installation  
 (3 of 3).

### 5.15 Front Cover Kit Installation

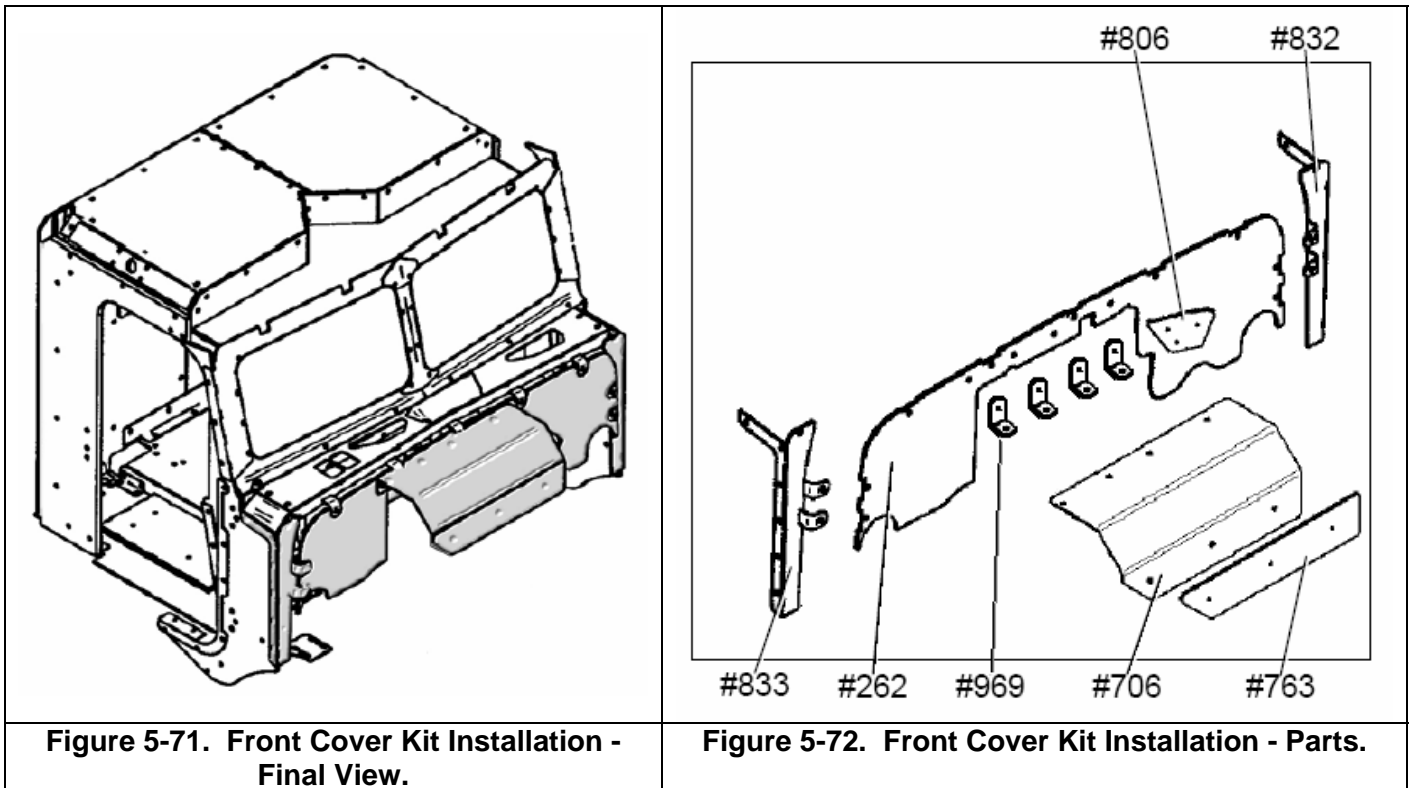


Figure 5-71. Front Cover Kit Installation - Final View.

Figure 5-72. Front Cover Kit Installation - Parts.

#### 5.15.1 Parts, Fasteners, Special Tools, and Materials

Parts (see Figure 5-72)				
Part No.	Alternate Part No.	Description	Find No. in Procedure	Quantity
0257022262-00	0257027362-00	Firewall External	#262	1
0257027706-00		Air Filter	#706	1
0257027763-00	0257027373-00	Overlap For Air Filter	#763	1
0257020806-00		Cover, Firewall	#806	1
0257020832-00		Cowl Armor External Side Left	#832	1
0257020833-00		Cowl Armor External Side Right	#833	1
0257020969-00		Bracket, Air Filter Armor	#969	4

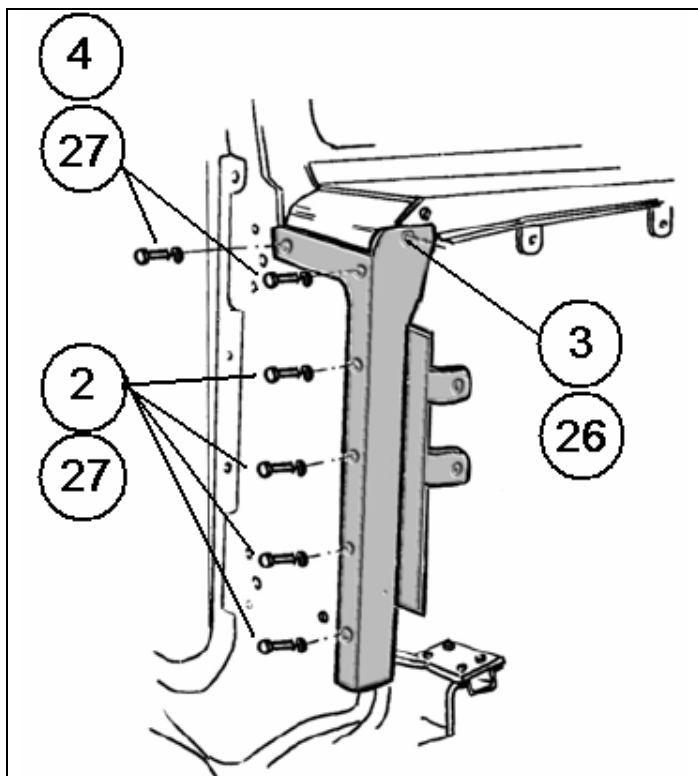
<b>Fasteners:</b>			
<b>Find No. (Table 3-5)</b>	<b>Description</b>	<b>Size</b>	<b>Quantity</b>
3	Bolt	5/16" x 1" NC	9
27	Flat washer	5/16" x 30 x 3	29
26	Flat washer	5/16" x 21 x 3	8
6	Bolt	5/16" x 1-1/2" NC	3
4	Bolt	5/16" x 1-1/4" NC	17
2	Bolt	5/16" x 3/4" NC	8

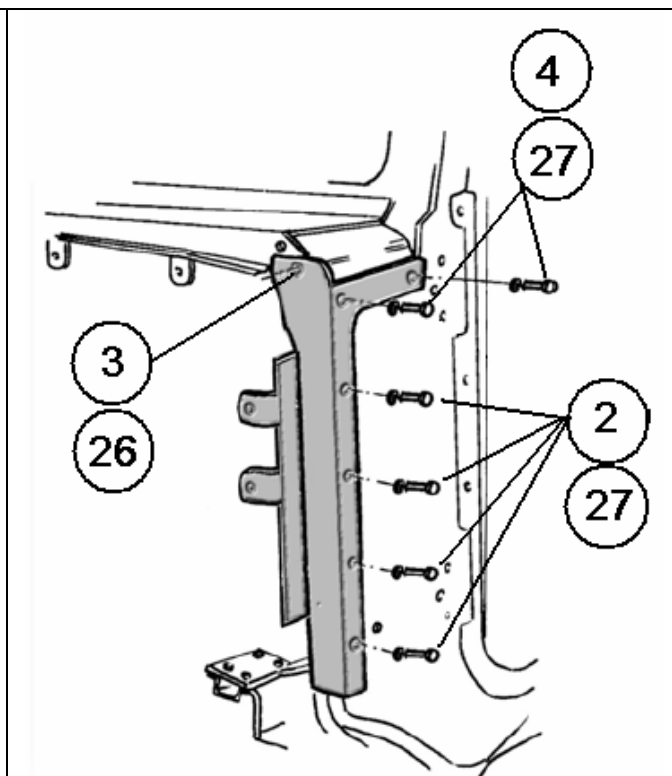
<b>Special Tools/ Materials</b>	
<b>Description:</b>	<b>Vendor/Part-Number:</b>
None	

### 5.15.2 Installation Instructions

1. Install Cowl Corners, #832 and #833, as shown in Figures 5-73 and 5-74. Note that the top two bolts being used were installed in the previous operations (5-13 and 5-14) and must be removed and reinstalled.



**Figure 5-73. Front Cover Kit Installation  
(1 of 5).**



**Figure 5-74. Front Cover Kit Installation  
(2 of 5).**



2. Install the firewall armor panel #262 as indicated in Figure 5-75.
3. Install four brackets # 969 to the air filter armor per Figure 5-76.
4. Install the air filter armor and brackets #969 on the firewall armor panel per Figure 5-77.
5. Install the air filter overlap, #763 and the firewall cover plate #806.

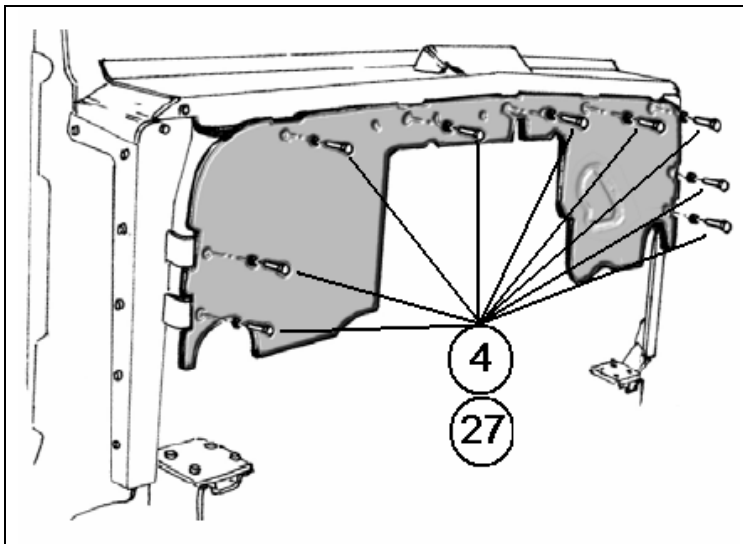


Figure 5-75. Front Cover Kit Installation (3 of 5).

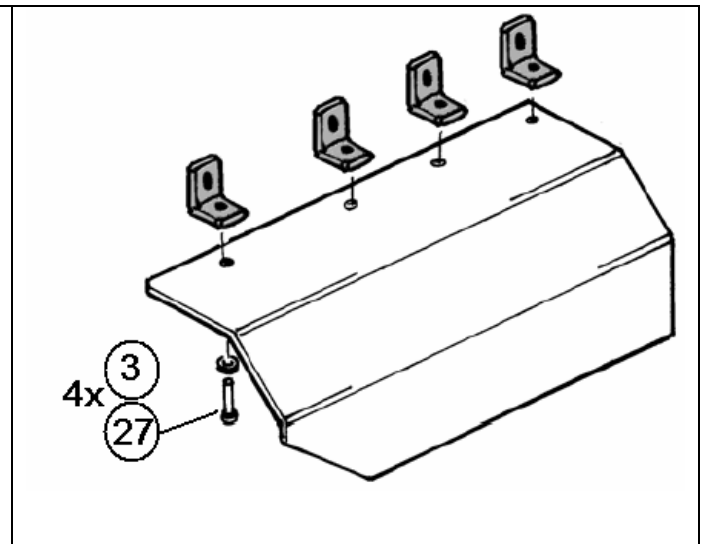


Figure 5-76. Front Cover Kit Installation (4 of 5).

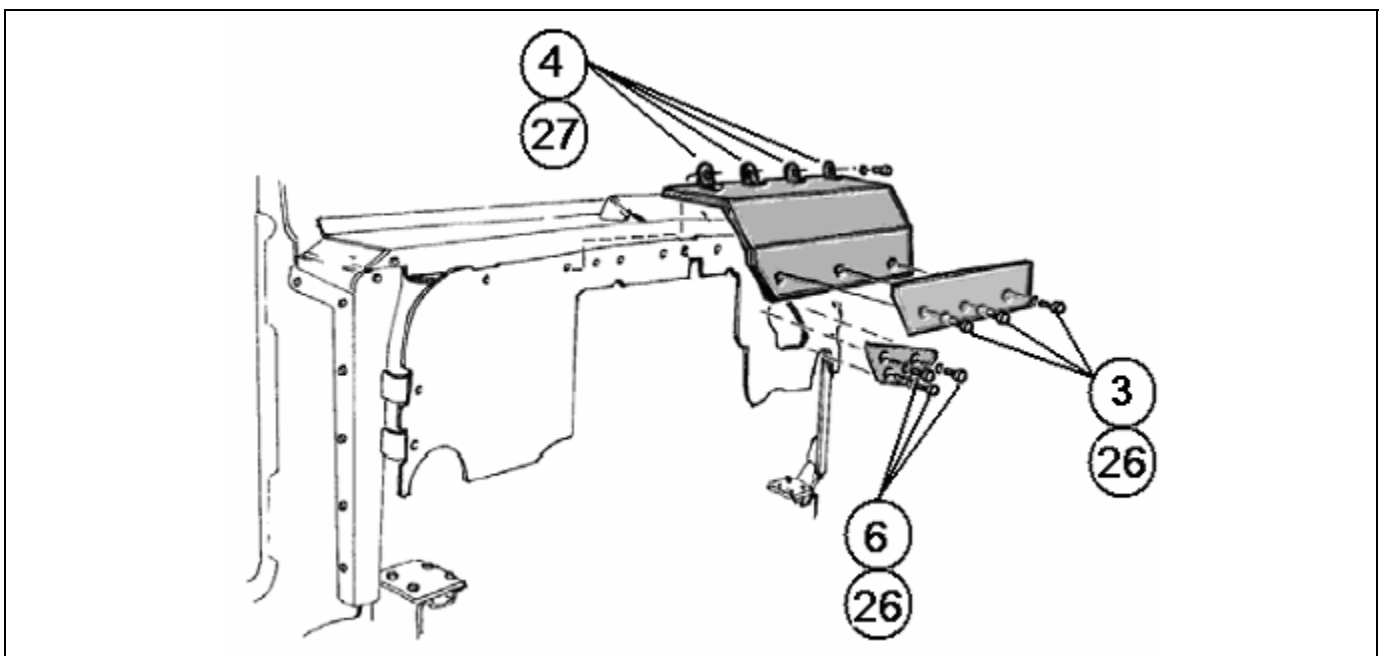
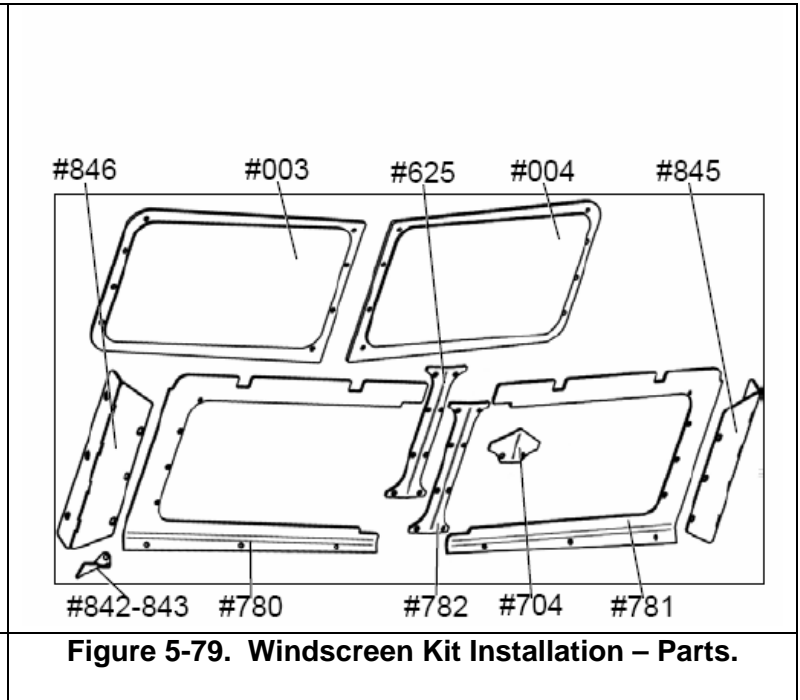
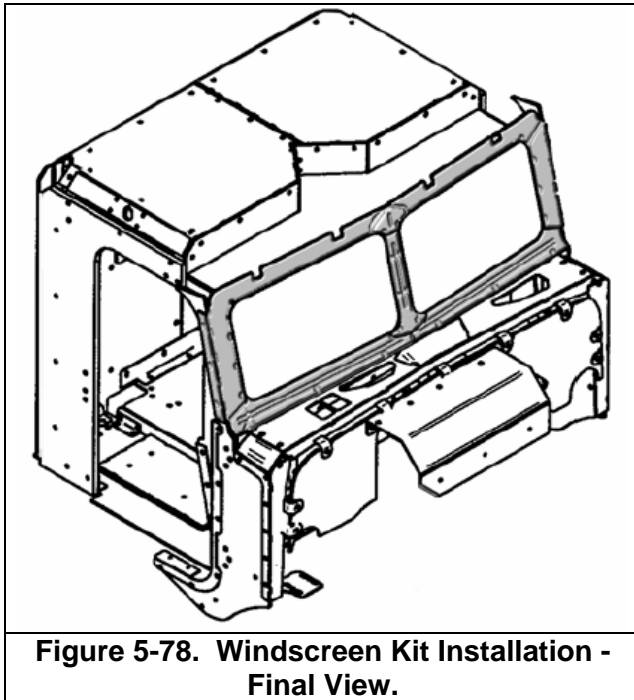


Figure 5-77. Front Cover Kit Installation (5 of 5).

### 5.16 Windscreen Kit Installation





#### 5.16.1 Parts, Fasteners, Special Tools, and Materials

Parts (see Figure 5-79)				
Part No.	Alternate Part No.	Description	Find No. in Procedure	Quantity
0257020003-00	0257020063-00	Front Window RH Assy	#003	1
0257020004-00	0257020064-00	Front Window LH Assy	#004	1
0257020625-00		Plate For Sealer Front Window	#625	1
0257017704-00		Central Windscreen Overlap Top	#704	1
0257027780-00		RH Windscreen Surround Overlap	#780	1
0257027781-00		LH Windscreen Surround Overlap	#781	1
0257027782-00		Central Windscreen Overlap Middle	#782	1
0257010842-00		Rear RH Corner External Fair Wall	#842	1
0257010843-00		Rear LH Corner External Fair Wall	#843	1
0257030845-00		LH A-Pillar Overlap 1 External	#845	1
0257030846-00		RH A-Pillar Overlap 1 External	#846	1

<b>Fasteners:</b>			
<b>Find No. (Table 3-5)</b>	<b>Description</b>	<b>Size</b>	<b>Quantity</b>
3	Bolt	5/16" x 1" NC	14
2	Bolt	5/16" x 3/4" NC	6
6	Bolt	5/16" x 1-1/2" NC	2
14	Bolt	3/8" x 1-3/4" NC	6
27	Flat washer	5/16" x 30 x 3	6
26	Flat washer	5/16" x 21 x 3	16
29	Flat washer	3/8" x 21 x 3	12
38	Flange Nut	3/8 NC	6
<b>Special Tools/ Materials</b>			
<b>Description:</b>		<b>Vendor/Part-Number:</b>	
Sika Primer		206	
Sikaflex Sealant		265 or 296	

### 5.16.2 Installation Instructions

	<p><b>IMPORTANT</b>            Before installation, clean the windshield rim and all relevant parts with mild detergent. Spread a layer of primer on the relevant surfaces. Before parts installation, spread a generous amount of Sikaflex on the adjoining side of all parts, on screws, and in all screw holes, to prevent water and moisture from entering the cabin.</p>
	<p><b>IMPORTANT</b>            The ballistic windshield can be easily fractured by improper installation. Do not tighten fasteners until all components are in place. Snug all fasteners slowly, check for any interference, correct as necessary, then tighten. Do not allow the Sikaflex sealant to cure before completion of the installation and tightening of the fasteners.</p>

1. The OEM windshield should have been removed during vehicle preparation. If not, remove at this time. Prepare the area around the windshield opening by cleaning the surrounding surface. Lay part #625 in place as shown in Figure 5-80.
2. Spread the supplied Sikaflex primer on the areas indicated by the dark lines around the windshield opening in Figure 5-81.
3. Spread Sikaflex primer on the mating areas of the windshield frames, #003 and #004.
4. Apply a generous bead of Sikaflex sealant on the cab in the primed area. Ensure to fully encircle all holes in the center plate #625 and apply a bead across each end of #625 to seal the ends to the cab.
5. Set the windshields in position as indicated in Figure 5-82. Ensure that the strike face is oriented to face forward. Use fasteners in the upper center locations to hold the windshield in position. Do not tighten the fasteners at this time.
6. Install the windshield surround overlaps, parts #780 and #781. Do not tighten fasteners at this time.
7. Install the A-pillar overlaps #845 and #846 at the corners and the corner fairings, #842 and #843 per Figures 5-84 and 5-85.
8. Install the center overlaps #782 and #704 per Figure 5-86.
9. Remove each fastener individually, apply thread-locking compound and reinstall. Snug all fasteners slowly (approx 5 - 10 ft-lb) check for any interference between the windshields and the cab, correct as necessary, then tighten to 35 ft-lb maximum.



**CAUTION**

**Do not use impact tools to tighten these fasteners! Windshield breakage could occur from the use of impact tools or excessive torque.**

10. Apply a bead of Sikaflex sealant between the top forward edge of the cab and the back upper surface of the windshield surround overlaps to prevent water runoff from the cab roof from getting behind the windshield surround overlaps.

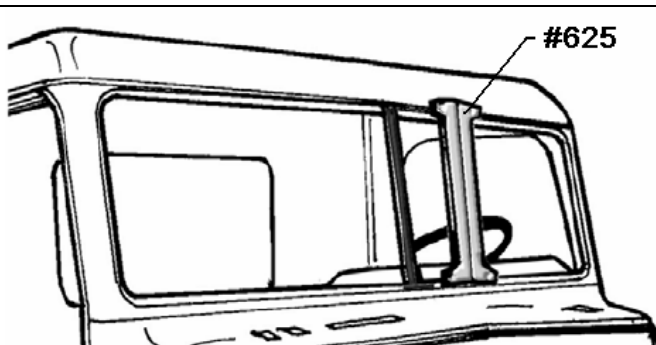


Figure 5-80. Windscreen Kit Installation (1 of 7).

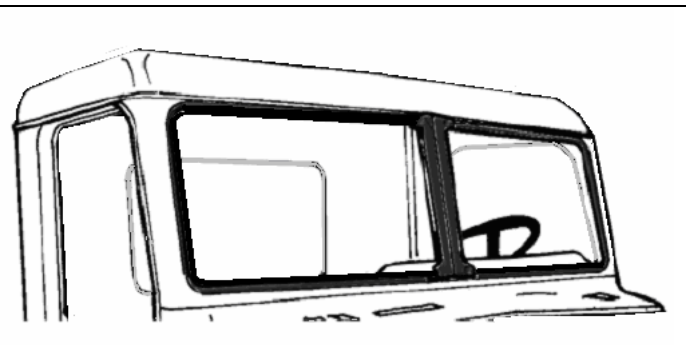


Figure 5-81. Windscreen Kit Installation (2 of 7).

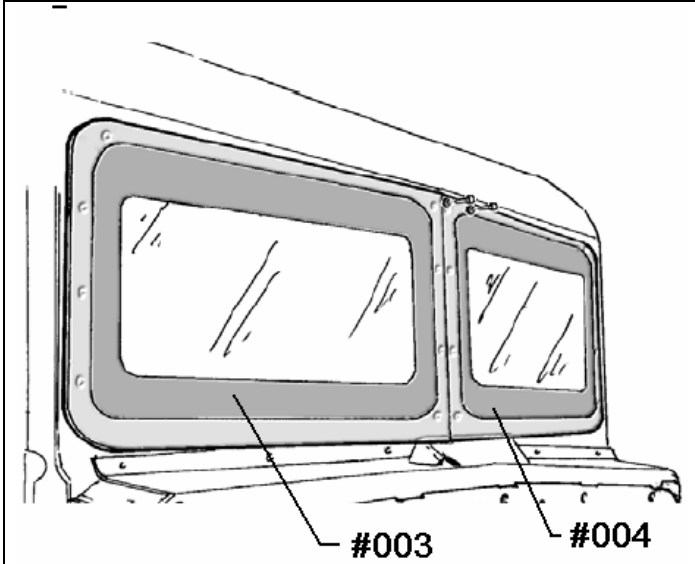


Figure 5-82. Windscreen Kit Installation (3 of 7).

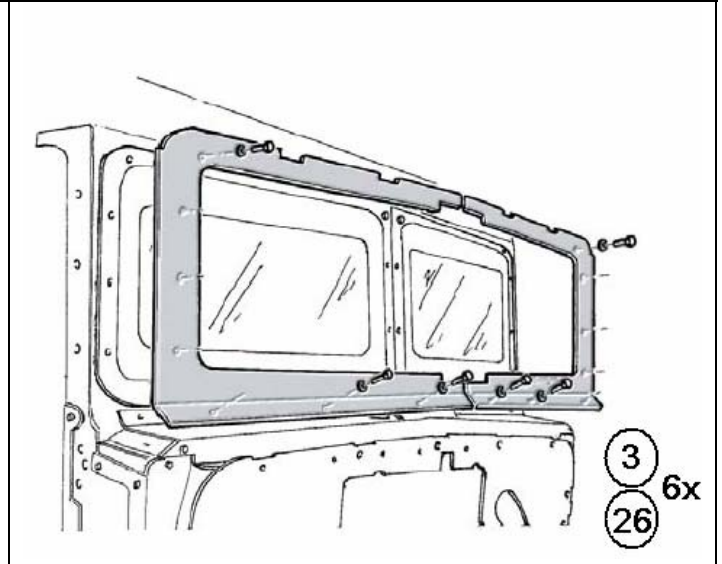


Figure 5-83. Windscreen Kit Installation (4 of 7).

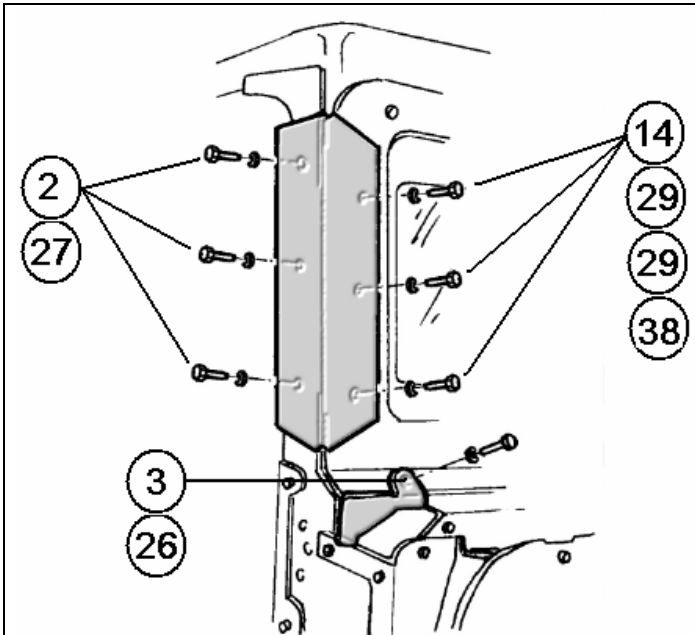


Figure 5-84. Windscreen Kit Installation -  
 Right Side (5 of 7).

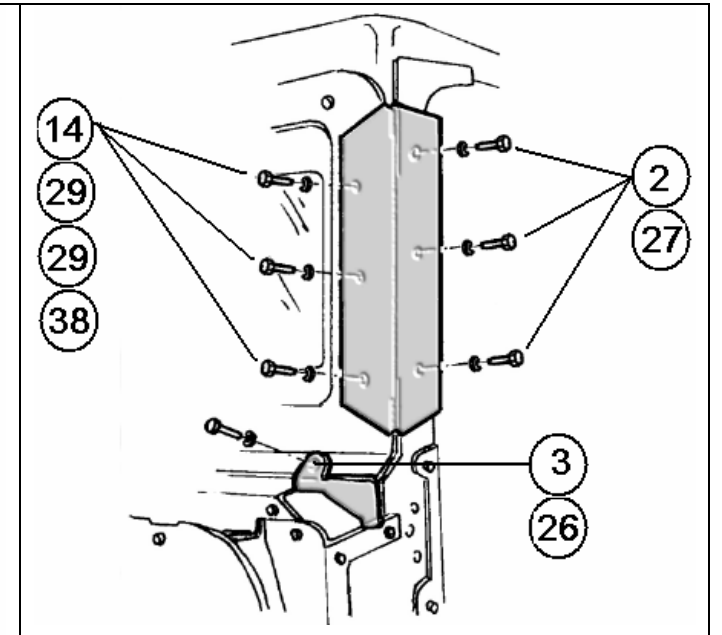
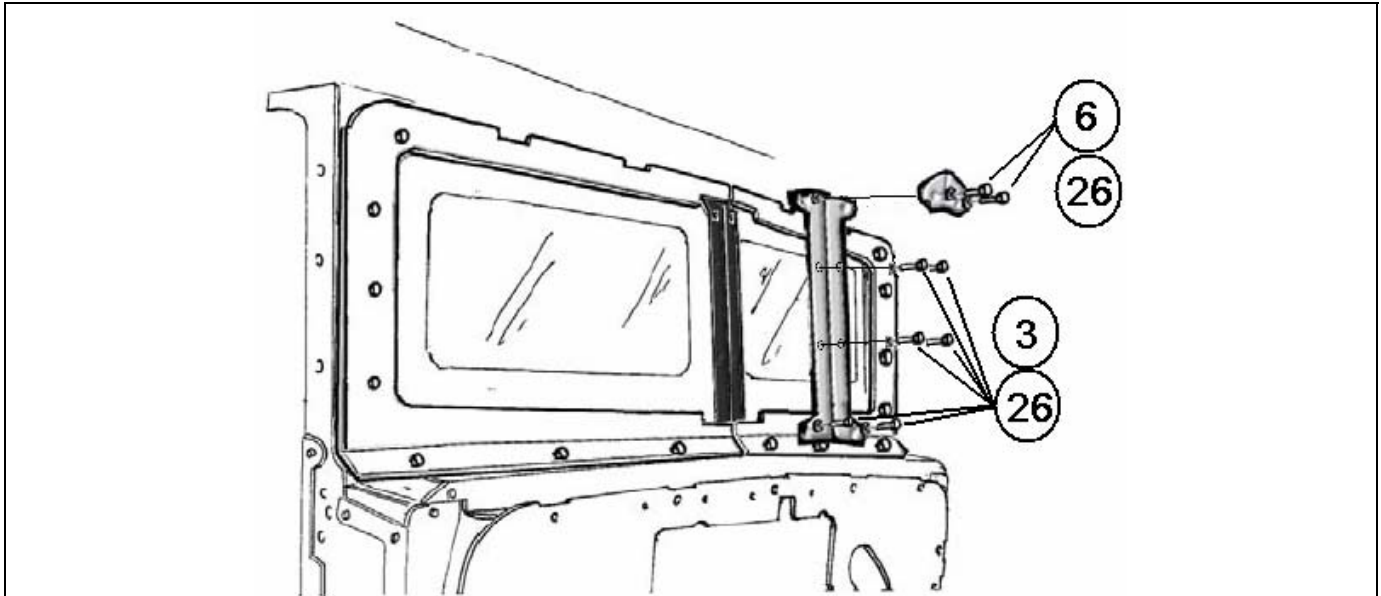


Figure 5-85. Windscreen Kit Installation -  
 Left Side (6 of 7).



**Figure 5-86. Windscreen Kit Installation (7 of 7).**



**IMPORTANT**

Upon completion of the Windscreen Kit Installation, remove each cabin bolt (one at a time), spread locking compound #243, re-install them, and tighten.

### 5.17 Seats Installation

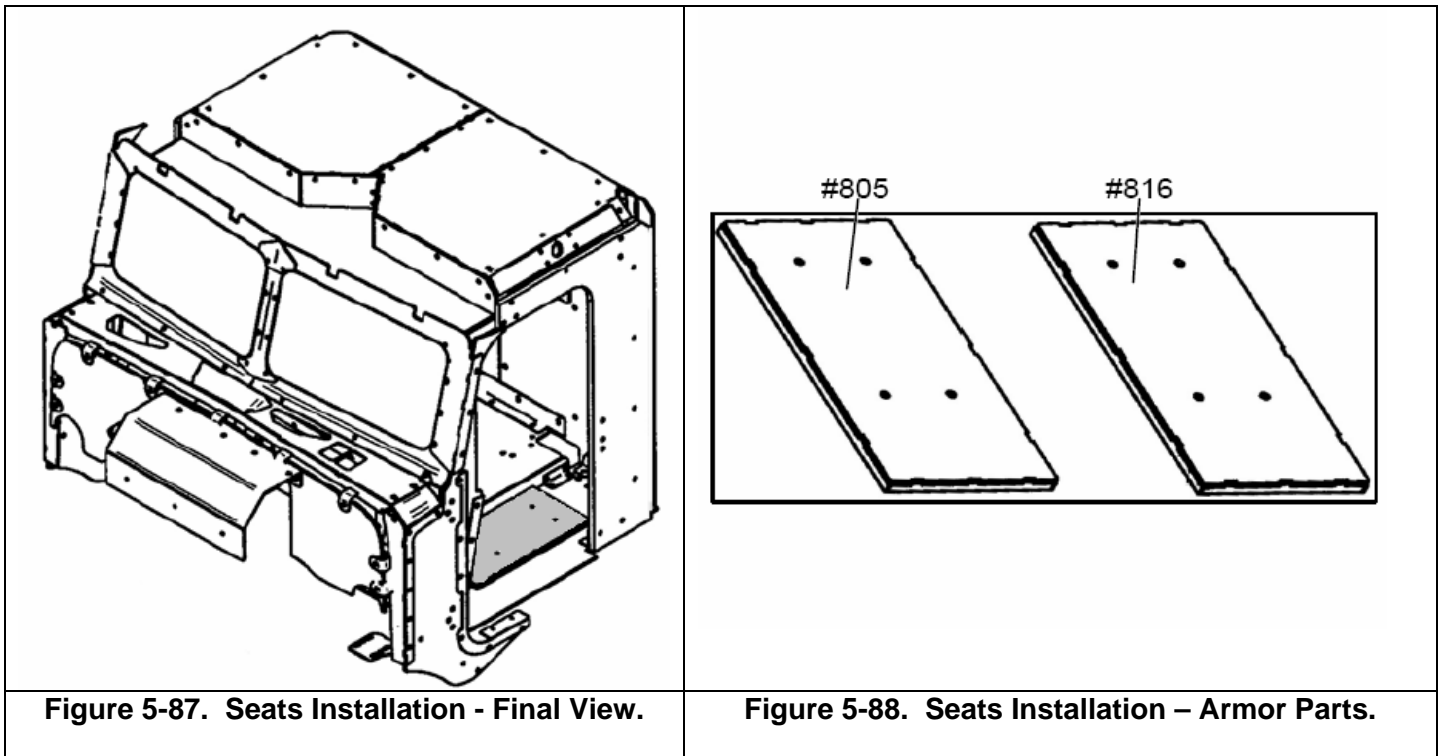


Figure 5-87. Seats Installation - Final View.

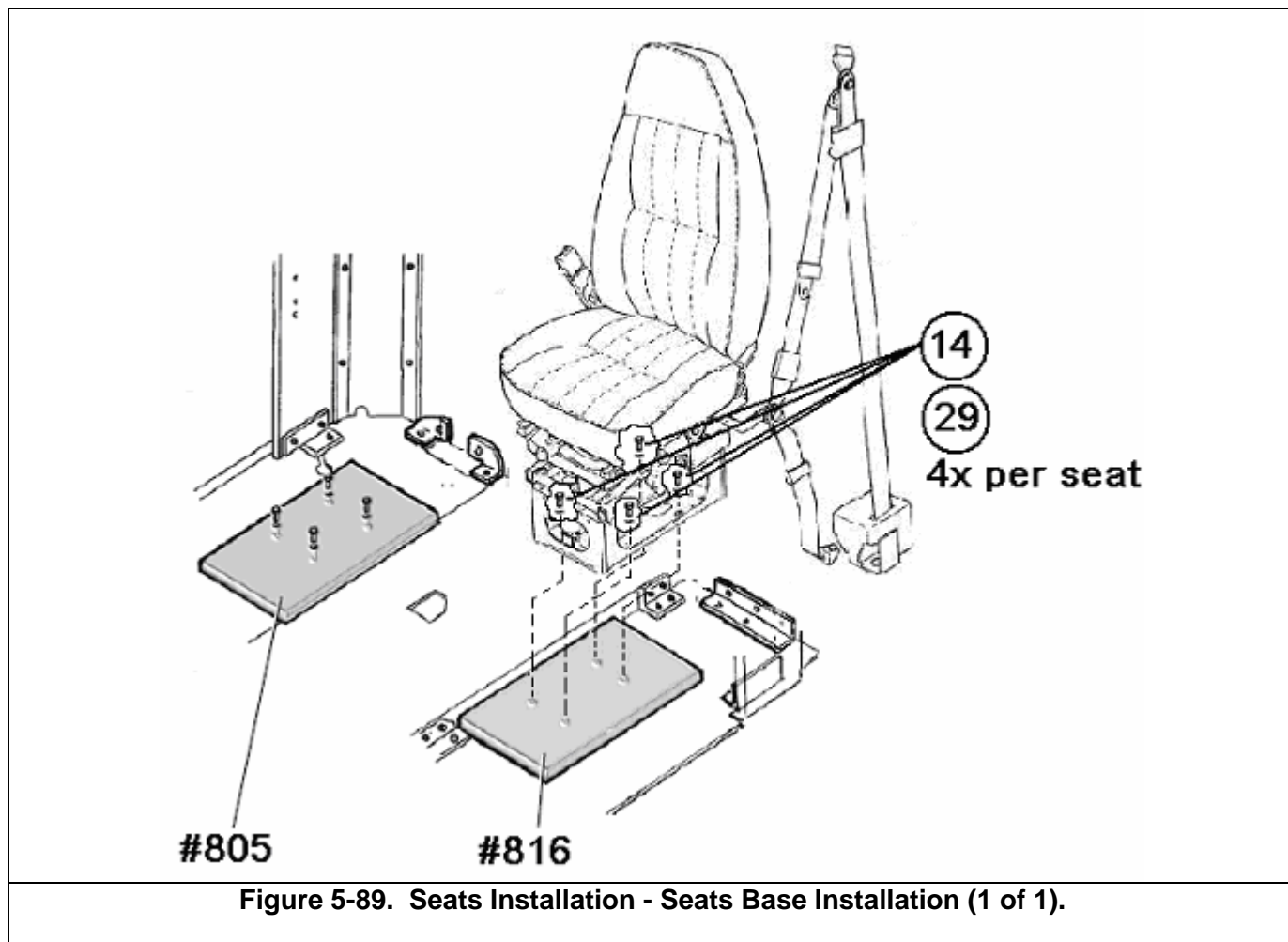
Figure 5-88. Seats Installation – Armor Parts.

#### 5.17.1 Parts, Fasteners, Special Tools, and Materials

Parts (see Figure 5-88)				
Part No.	Alternate Part No.	Description	Find No. in Procedure	Quantity
02570120805-00		Seat Base, Passenger Floor	#805	1
02570120816-00		Seat Base, Driver's Floor	#816	1
<b>Fasteners:</b>				
Find No. (Table 3-5)	Part No.	Description	Size	Quantity
14	5310000260-00	Bolt	3/8 x1 3/4	8
29	5320000046-00	Flat Washer	3/8 x 21 x 3	8
<b>Special Tools/ Materials</b>				
<b>Description:</b>		<b>Vendor/Part-Number:</b>		
None				

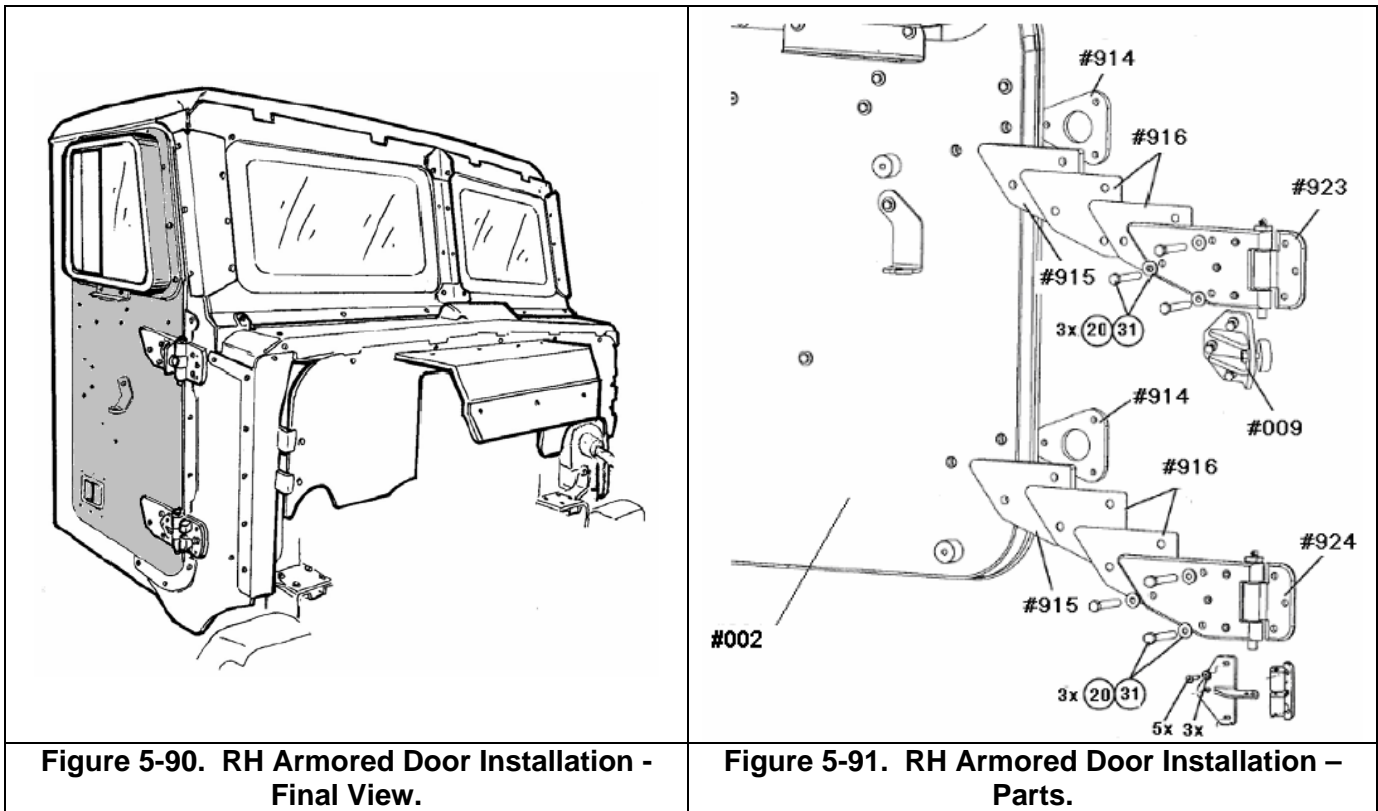
### 5.17.2 Installation Instructions

1. Set panel #805 in place over the floor armor panel on the passenger's side as shown in Figure 5-89. Align the holes through #805 with the OEM seat mounting nut plates in the cab floor.
2. Set Panel #816 in place over the floor armor panel on the driver's side as shown in Figure 5-89. Align the holes through #816 with the OEM seat mounting nut plates in the cab floor.
3. Set the driver's seat in position as shown in Figure 5-89. Install the indicated bolts and washers. Re-attach the restraint system to the seat as required. Repeat for the passenger's seat.





### 5.18 RH Armored Door Installation




#### 5.18.1 Parts, Fasteners, Special Tools, and Materials

Parts (see Figure 5-91)				
Part No.	Alternate Part No.	Description	Find No. in Procedure	Quantity
0257040002-00		Door Assy, RH	#002	1
0257040009-00		Door Bumper Assy	#009	1
0257040914-00*		Spacer for Hinge Door Internal	#914	2
0257040915-00*		Spacer for Hinge Door EXT 16	#915	2
0257040916-00*		Spacer for Hinge Door EXT 2	#916	4
0257040923-00*		RH Upper Hinge Assy	#923	1
0257040925-00*		RH Lower Hinge Assy	#925	1

\*Components and Fasteners are supplied as part of 0257040002-00.

<b>Fasteners:</b>			
<b>Find No. (Table 3-5)</b>	<b>Description</b>	<b>Size</b>	<b>Quantity</b>
19	Bolt, Hex UNF	7/16" x 1"	5
31	Flat Washer	7/16" x 23 x 3	1
20*	Bolt Hex UNF	7/16" x 2-3/4	6
67	Bolt, Hex UNF	7/16" x 1-1/2"	1
<b>Special Tools/ Materials</b>			
<b>Description:</b>		<b>Vendor/Part-Number:</b>	
Heavy Lift Equipment - Fork lift or similar		N/A	

\*Components and Fasteners are supplied as part of 0257040002-00.

	<p><b>LIFT HAZARD</b>                  Use proper lifting device to lift and to install the door. Lift the door only from the lifting anchoring points.</p>
---	---

## 5.18.2 Installation Instructions

1. Assemble the upper hinge and spacers (#914, #915, #916 and #923) to the door. The spacer #914 is positioned on the inside surface of the door; all other items are on the outside surface of the door. Note that spacers #915 and #916 are provided to allow adjustment of the door, and that not all spacers may be needed; however, the same number and combination of spacers should be used on the upper and lower hinge for each application. Snug the bolts down, but do not fully tighten at this time.
2. Assemble the lower hinge and spacers (#914, #915, #916, and #924) to the door. The spacer #914 is positioned on the inside surface of the door; all other items are on the outside surface of the door. Snug the bolts down, but do not fully tighten at this time.
3. Raise the door into position with a fork lift or similar lifting device. Install bolts (19) and washers (31) to attach the hinges to the cab. Omit the center bolt on the lower hinge at this time. Refer to Figure 5-92. Snug the bolts down, but do not fully tighten at this time. Note that washers are not used on these bolts.
4. Adjust the position of the door so that it is properly aligned with the door opening and the striker post. Ensure that the door is high enough to prevent the door seal from dragging on the door step.
5. Adjust the position of the hinges to provide centerline alignment of the upper and lower hinge pins. Laying a straight edge from the upper hinge pin knuckles to the lower hinge pin knuckles will aid this task.
6. Tighten the hinge bolts and remove the lift device. Verify operation of the door. Adjust the hinges as necessary to achieve smooth operation of the door.
7. Remove each bolt individually, apply thread-locking compound, re-install the bolt and tighten.
8. Install the door detent as shown in Figure 5-94. Snug the bolts down, but do not fully tighten at this time.
9. Install the door bumper as shown in Figure 5-95. These fasteners may be fully tightened.
10. Operate the door through the full-open position. Align the door detent components as necessary to ensure that there is not interference or bending load applied to the components. After satisfactory alignment is achieved, tighten the fasteners.
11. Adjust the ball-spring plungers in the door detent as required to obtain satisfactory detent force.
12. Install OEM mirrors using original hardware. For electric mirrors, remove the bolt indicated in Figure 5-92 and pass the wire through the resulting hole.

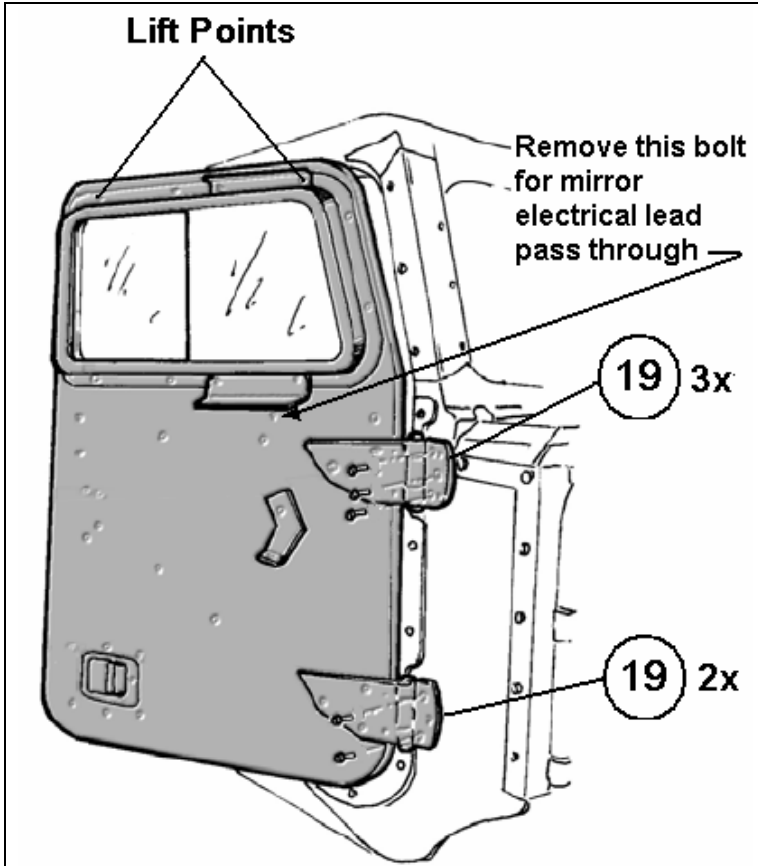


Figure 5-92. RH Armored Door Installation (1 of 4).

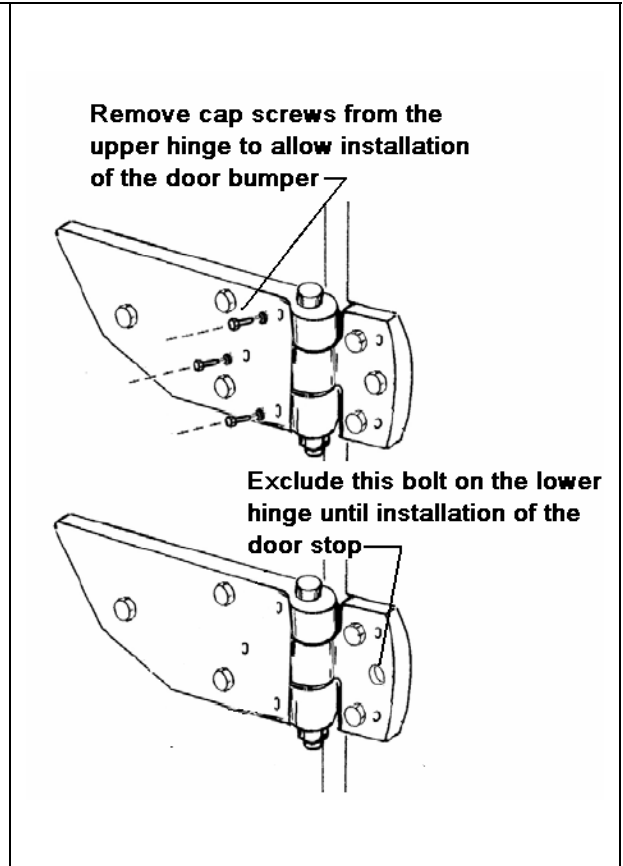


Figure 5-93. RH Armored Door Installation (2 of 4).

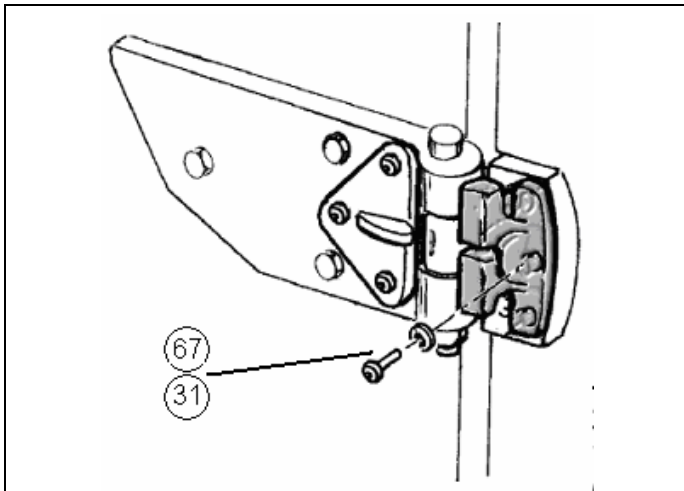


Figure 5-94. RH Armored Door Installation - Lower Hinge, Door Detent (3 of 4).

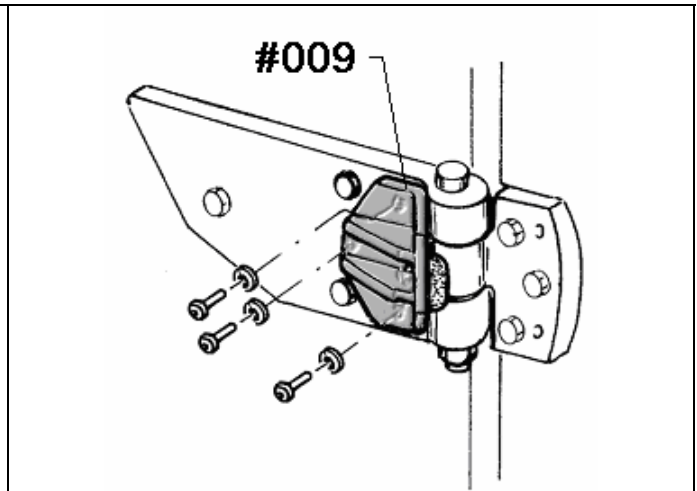


Figure 5-95. RH Armored Door Installation - Upper Hinge, Door Bumper (4 of 4).

## 5.19 RH Door Accessories Assembly

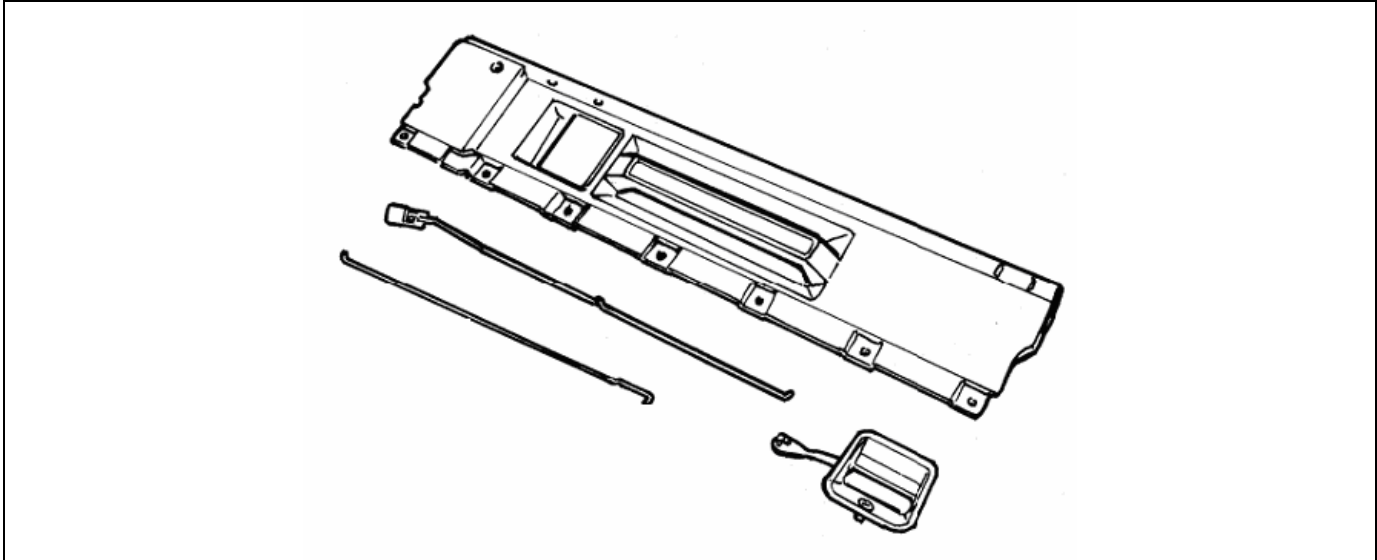
### 5.19.1 Parts, Fasteners, Special Tools, and Materials

Parts				
Part No.	Alternate Part No.	Description	Find No. in Procedure	Quantity
NA		NA		
<b>Fasteners:</b>				
Find No. (Table 3-5)	Part No.	Description	Size	Quantity
53*		Bolt, HEX, NC	1/4" x 1/2"	3
Special Tools/ Materials				
Description:		Vendor/Part-Number:		
None				

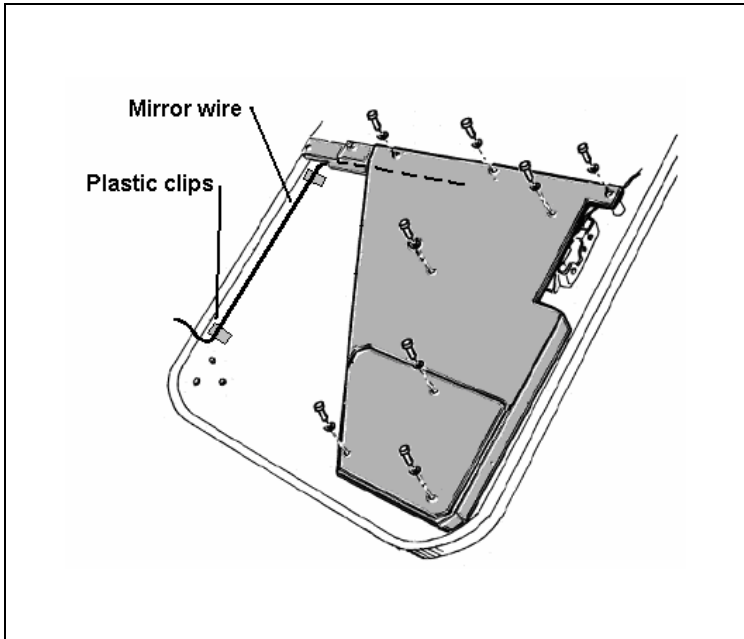
\*Fasteners are supplied as part of 0257040002-00.

### 5.19.2 Installation Instructions

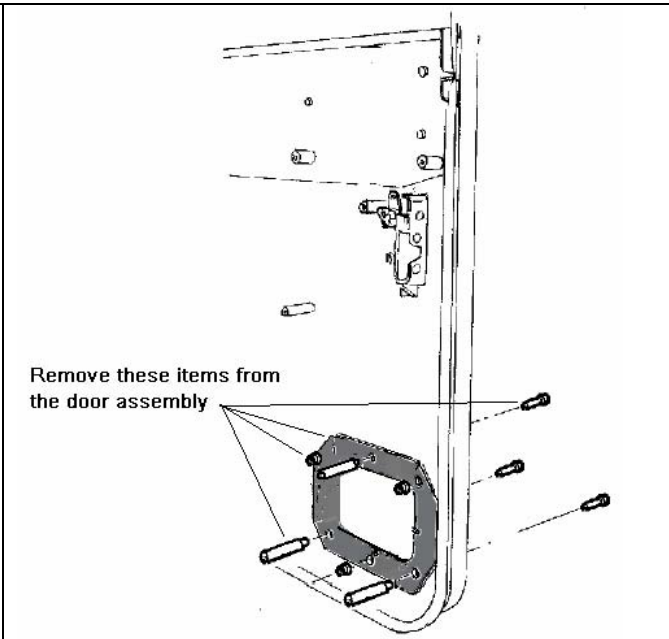
1. From the OEM door, remove the external door handle, the internal door handle with its housing and linkage, and the interior lock button with linkage. These items are illustrated in Figure 5-96. Remove the felt wiper strip from the top edge of the OEM door handle assembly.
2. Remove the interior cover from the armored door as shown in Figures 5-97.
3. Remove the external door handle adaptor plate from the armored door as shown in Figure 5-98.
4. Route the mirror wire under the internal door cover plate as shown in Figure 5-102. Secure to the door with plastic clips (P/N 534000028-00) near the forward edge.
5. Assemble the OEM external door handle into the door handle adaptor plate as shown in Figure 5-99.
6. Connect linkages as illustrated in Figure 5-100. Operate the internal and external handles as well as the lock button to ensure that all items function correctly. Close the door to verify proper operation of the latch mechanism. Adjust the position of the latch and the striker post as necessary.
7. Reinstall the components on the door as shown in Figures 5-101 and 5-102 using the hardware removed from the armored door.



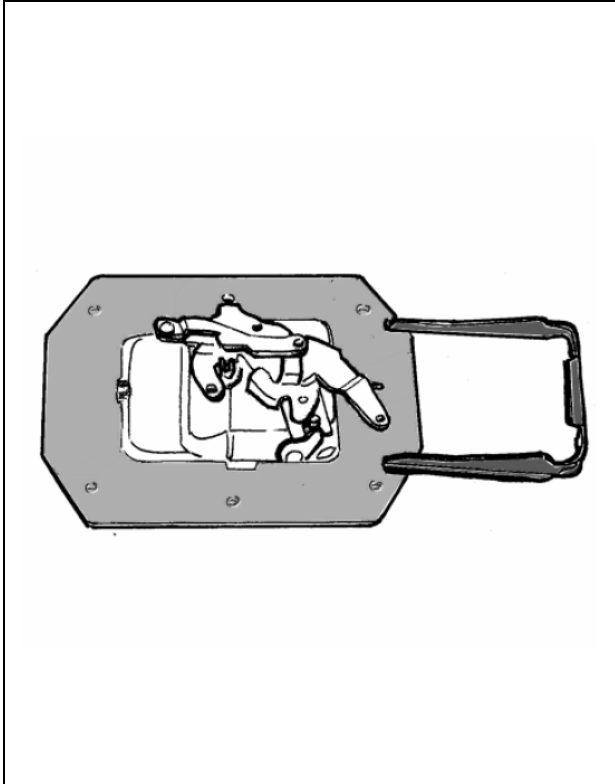
**Figure 5-96. RH Door Accessories Assembly - Parts Removed from the OEM Door.**



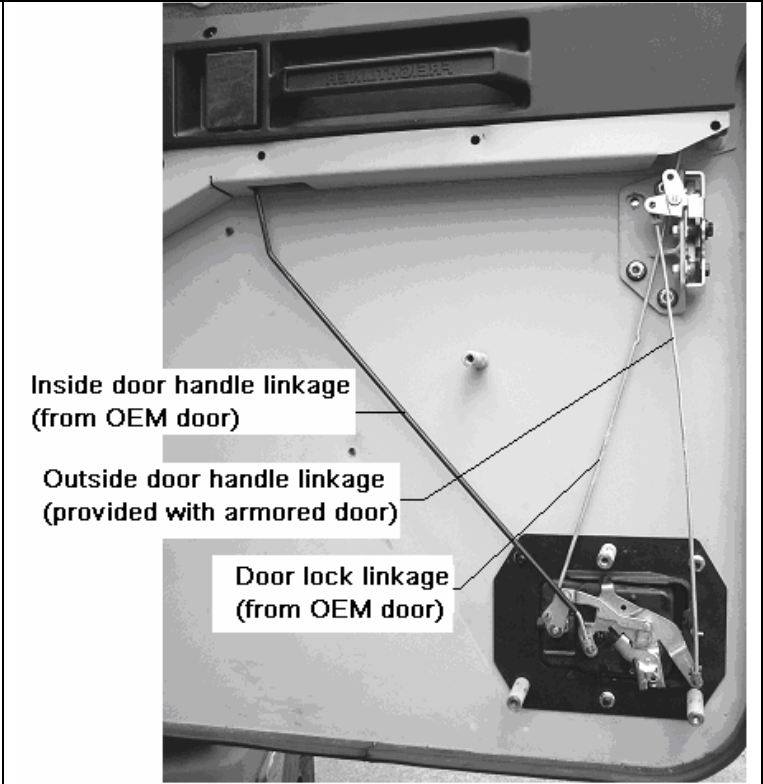
**Figure 5-97. RH Door Accessories Assembly  
(1 of 6).**



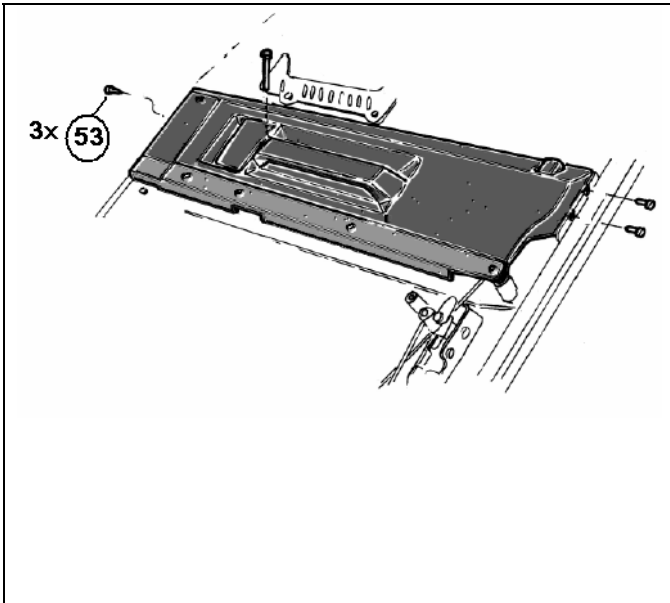
**Figure 5-98. RH Door Accessories Assembly  
(2 of 6).**



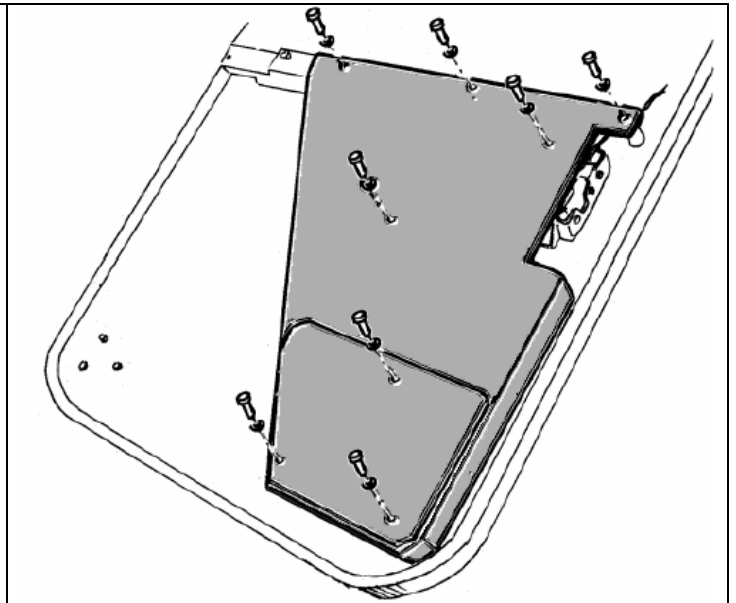
**Figure 5-99. RH Door Accessories Assembly (3 of 6).**



**Figure 5-100. RH Door Accessories Assembly (4 of 6).**

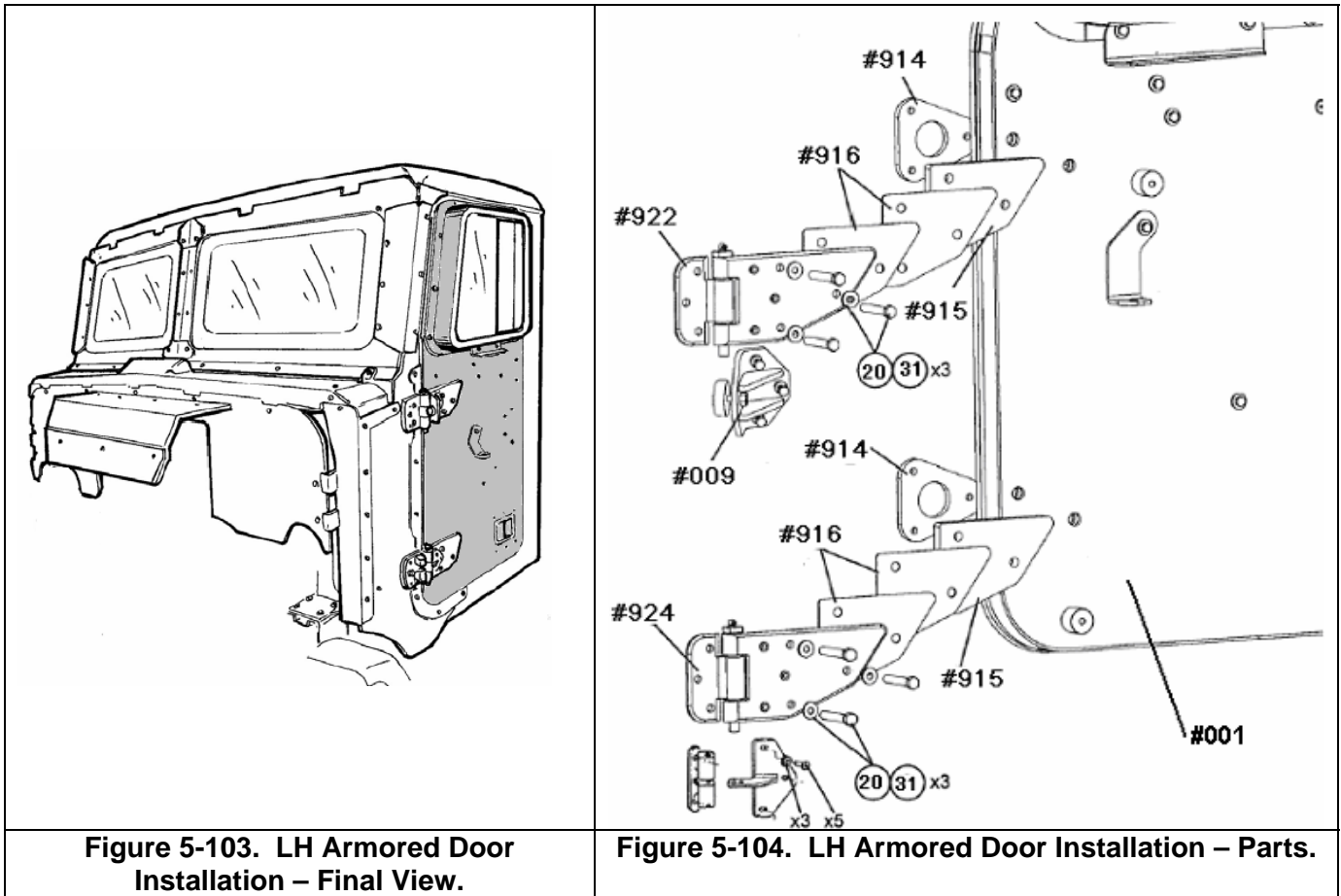


**Figure 5-101. RH Door Accessories Assembly (5 of 6).**



**Figure 5-102. RH Door Accessories Assembly (6 of 6).**

## 5.20 LH Armored Door Installation



**Figure 5-103. LH Armored Door Installation – Final View.**

**Figure 5-104. LH Armored Door Installation – Parts.**



**LIFT HAZARD**

Use proper lifting device to lift and to install the door. Lift the door only from the lifting anchoring points

### 5.20.1 . Parts, Fasteners, Special Tools, and Materials

Parts (see Figure 5-104)

Part No.	Alternate Part No.	Description	Find No. in Procedure	Quantity
0257040001-00		Door Assy, LH	#001	1
0257040009-00		Door Bumper Assy	#009	1
0257040914-00*		Spacer for Hinge Door Internal	#914	2
0257040915-00*		Spacer for Hinge Door EXT 16	#915	2
0257040916-00*		Spacer for Hinge Door EXT 2	#916	4
0257040922-00*		LH Upper Hinge Assy	#922	1
0257040924-00*		LH Lower Hinge Assy	#924	1

\*Components and Fasteners are supplied as part of 0257040001-00.



<b>Fasteners:</b>			
<b>Find No. (Table 3-5)</b>	<b>Description</b>	<b>Size</b>	<b>Quantity</b>
19	Bolt, Hex UNF	7/16" x 1"	5
31	Flat Washer	7/16" x 23 x 3	1
20*	Bolt Hex UNF	7/16" x 2-3/4"	6
67	Bolt, Hex UNF	7/16" x 1-1/2"	1

<b>Special Tools/ Materials</b>	
<b>Description:</b>	<b>Vendor/Part-Number:</b>
Heavy Lift Equipment - Fork lift or similar	NA

\*Components and Fasteners are supplied as part of 0257040001-00.

### 5.20.2 Installation Instructions

1. Installation of the left-hand door is identical to installation of the right-hand door described in Section 5.18.1 with the exception of differing part numbers. Repeat procedures outlined in 5.18.1 using parts and illustrations in this section.

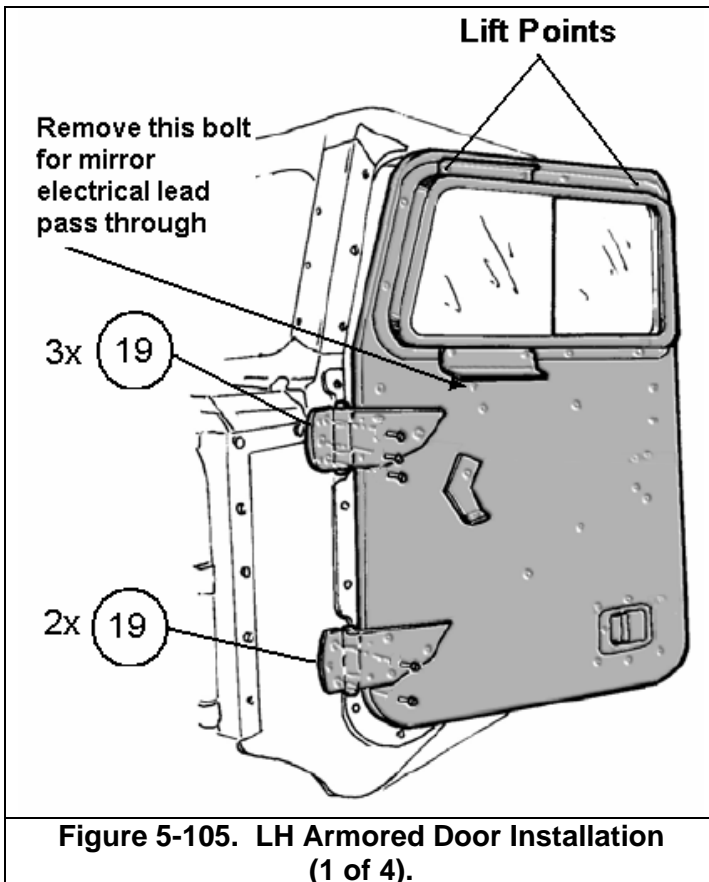


Figure 5-105. LH Armored Door Installation  
(1 of 4).

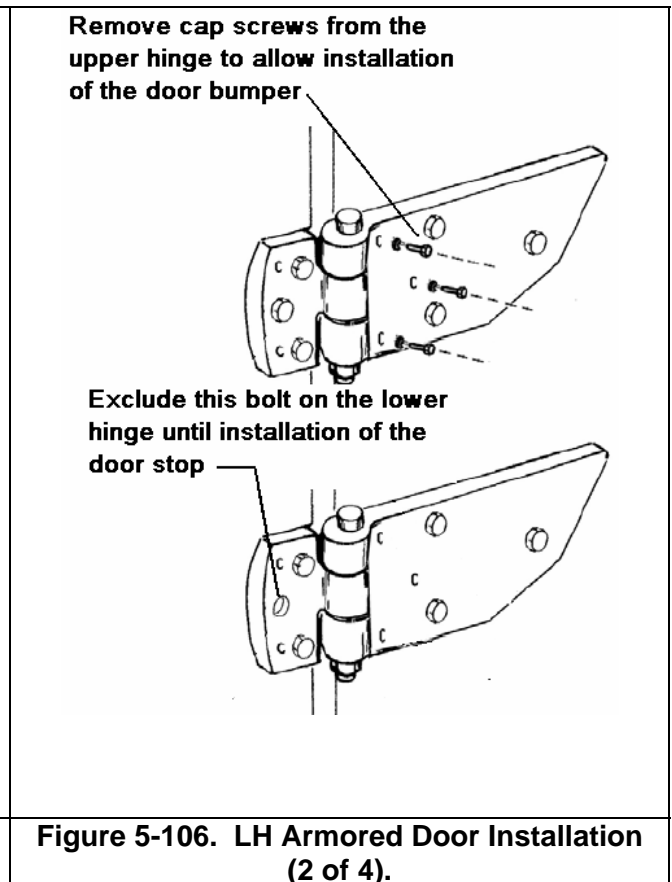
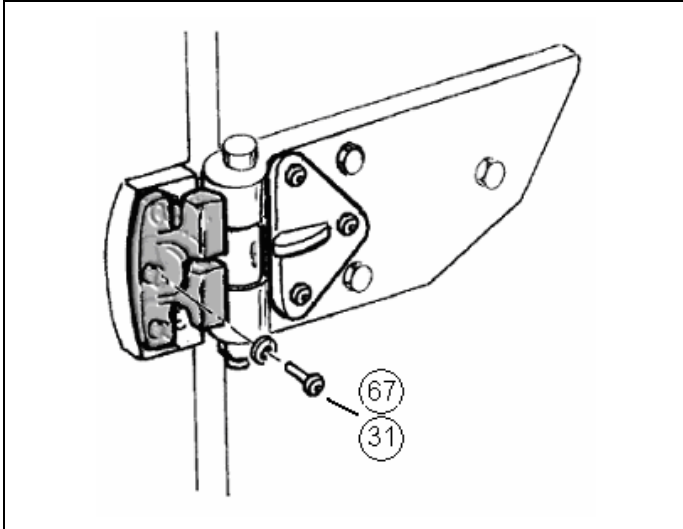
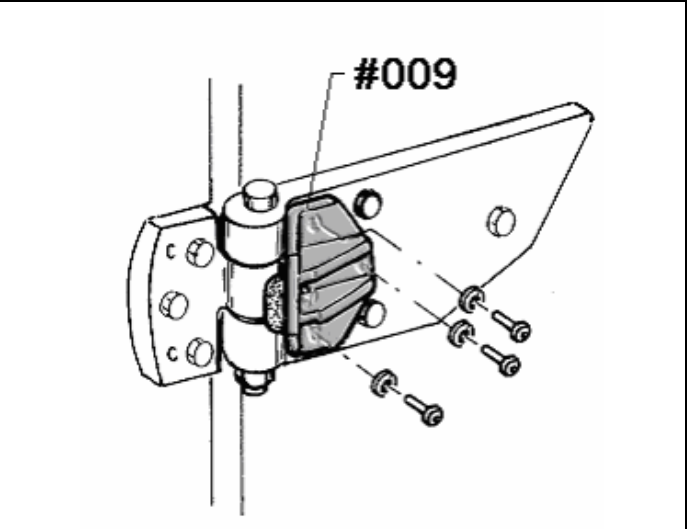


Figure 5-106. LH Armored Door Installation  
(2 of 4).



**Figure 5-107. LH Armored Door Installation - Lower Hinge, Door Detent (3 of 4).**



**Figure 5-108. LH Armored Door Installation - Upper Hinge, Door Bumper (4 of 4).**

## 5.21 LH Door Accessories Assembly

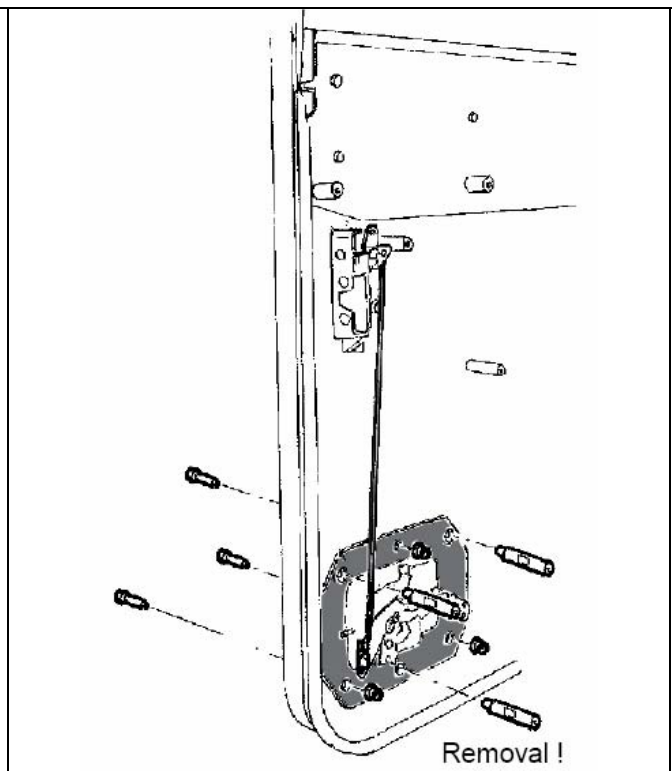
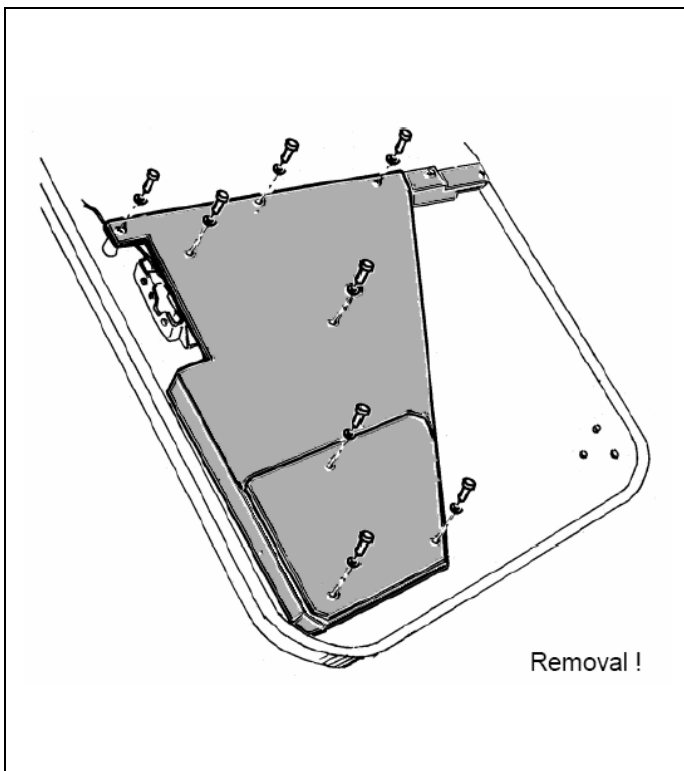
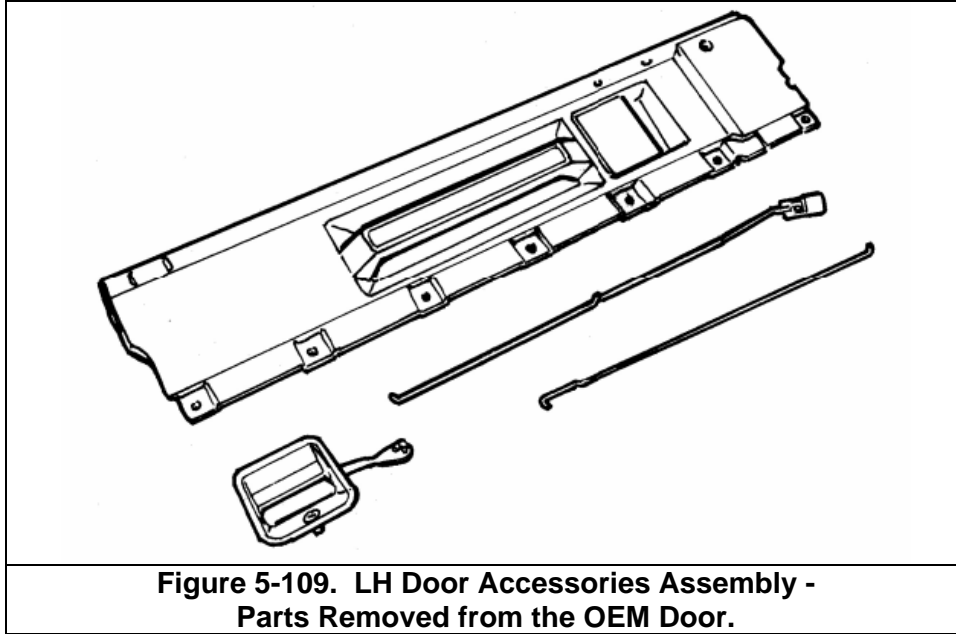
### 5.21.1 Parts, Fasteners, Special Tools, and Materials

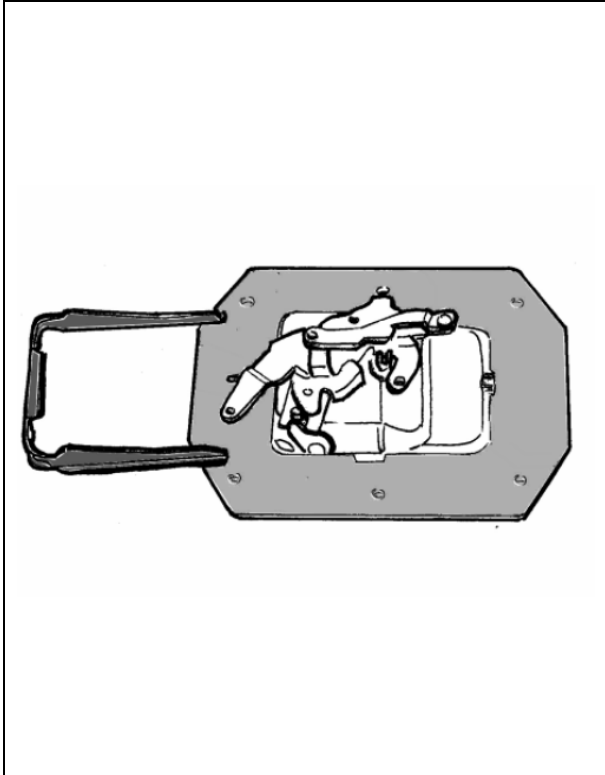
Parts				
Part No.	Alternate Part No.	Description	Find No. in Procedure	Quantity
NA		NA		
<b>Fasteners:</b>				
Find No. (Table 3-5)	Part No.	Description	Size	Quantity
53*		Bolt, HEX, NC	1/4" x 1/2"	3
Special Tools/ Materials				
Description:		Vendor/Part-Number:		
None				

\*Fasteners are supplied as part of 0257040001-00.

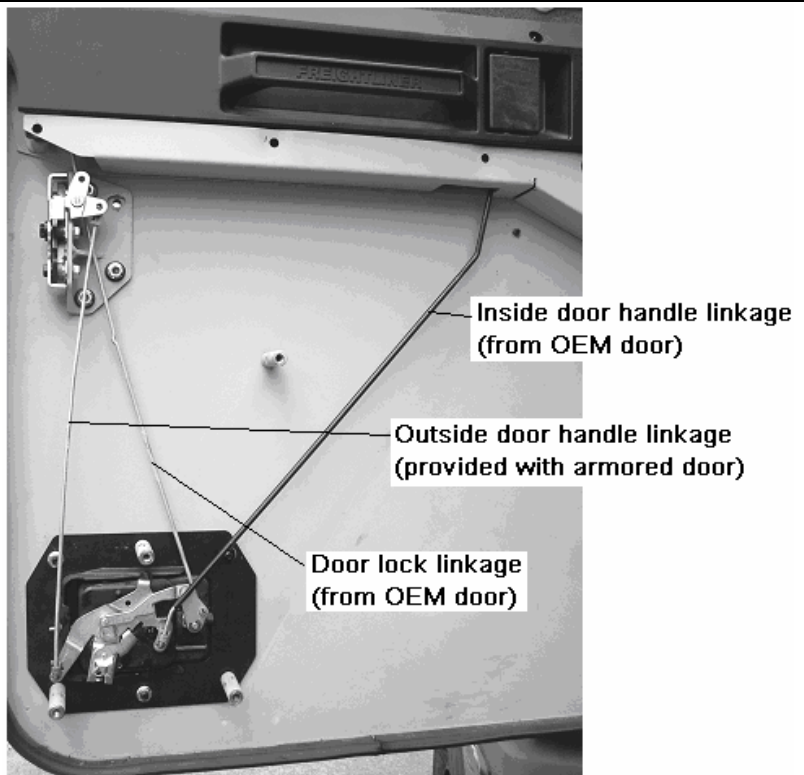
### 5.21.2 Installation Instructions

1. From the OEM door, remove the external door handle, the internal door handle with its housing and linkage, and the interior lock button with linkage. These items are illustrated in Figure 5-109. Remove the wiper strip from the top edge of the OEM door handle assembly.
2. Remove the interior cover from the armored door as shown in Figure 5-110.
3. Remove the external door handle adaptor plate from the armored door as shown in Figure 5-111.
4. Route mirror wire under the internal door cover plate as shown in Figure 5-115. Secure the wire to the door with plastic clips (P/N 53000028-00) near the forward edge.
5. Assemble the OEM external door handle into the door handle adaptor plate as shown in Figure 5-112.
6. Connect linkages as illustrated in 5-113. Operate the internal and external handles as well as the lock button to ensure that all items function correctly. Close the door to verify proper operation of the latch mechanism. Adjust the position of the latch and the striker post as necessary.
7. Reinstall the components on the door as shown in Figures 5-114 and 5-115 using the hardware removed from the armored door.

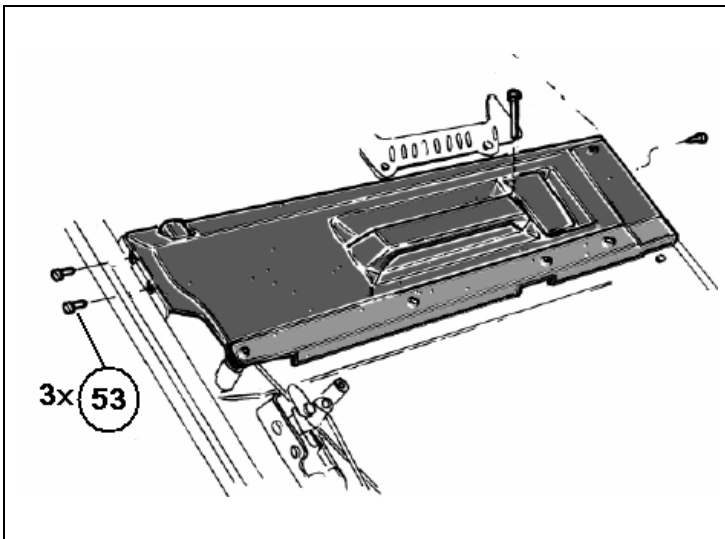




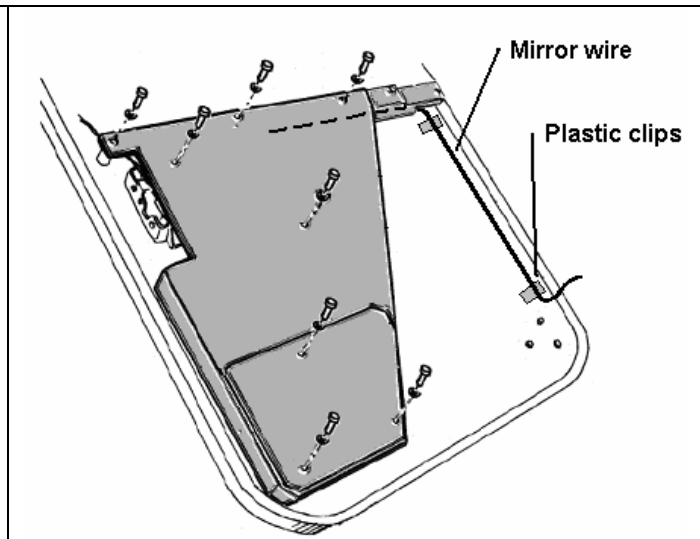
**Figure 5-112. LH Door Accessories Assembly - Assembly of External Door Handle (3 of 6).**



**Figure 5-113. LH Door Accessories Assembly - Assembly of external Door Handle (4 of 6).**

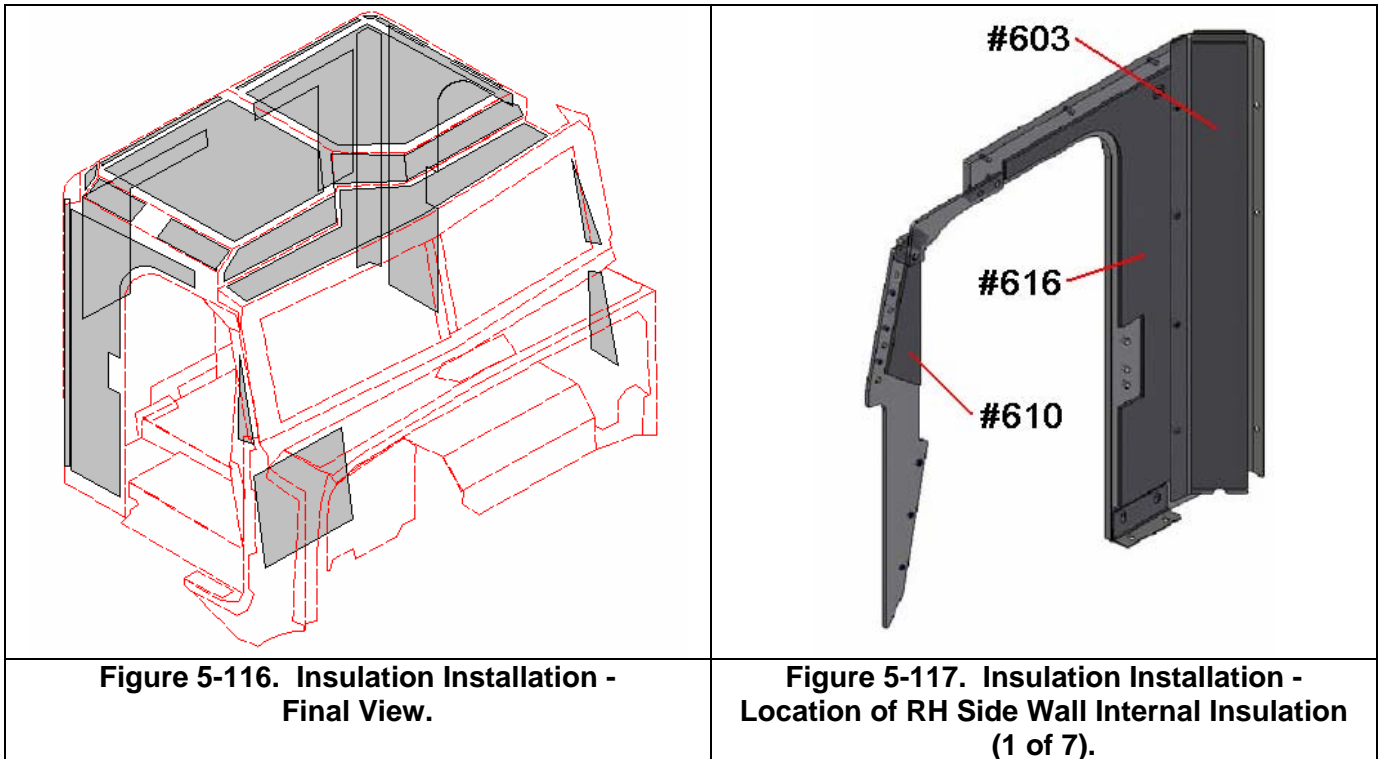


**Figure 5-114. LH Door Accessories Assembly - Reassembly of Armored Door (5 of 6).**



**Figure 5-115. LH Door Accessories Assembly - Reassembly of Armored Door (6 of 6).**

## 5.22 Insulation Installation



### 5.22.1 Parts, Fasteners, Special Tools, and Materials

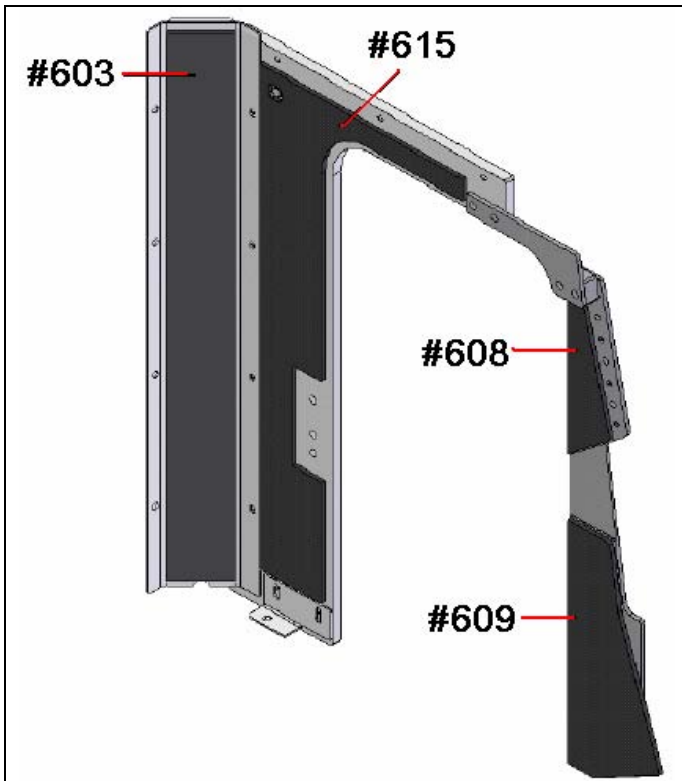
Parts (see Figure 5-117 through 5-123)

Part No.	Alternate Part No.	Description	Find No. in Procedure	Quantity
0257950601		Insulation, Right Rear	#601	1
0257950602		Insulation, Left Rear	#602	1
0257950603		Insulation, Rear Corner B Pillar	#603	2
0257950604		Insulation, Roof to Rear Overlap	#604	1
0257950605		Insulation, Roof to Rear Overlap	#605	1
0257950606		Insulation, Roof to Side Overlap	#606	2
0257950607		Insulation, Roof to Side Overlap	#607	2
0257950608		Insulation, LH A Pillar Upper	#608	1
0257950609		Insulation, LH A Pillar Lower	#609	1
0257950610		Insulation, RH A Pillar Upper	#610	1
0257950611		Insulation, Roof LH	#611	1
0257950612		Insulation, Roof RH	#612	1
0257950613		Insulation, Roof Front 1	#613	1
0257950614		Insulation, Roof Front 2	#614	1
0257950615		Insulation, Left Side	#615	1
0257950616		Insulation, Right Side	#616	1
0257950617		Insulation, Kick Panel	#617	1
0257950618		Insulation, Upper Rear Corner	#618	2

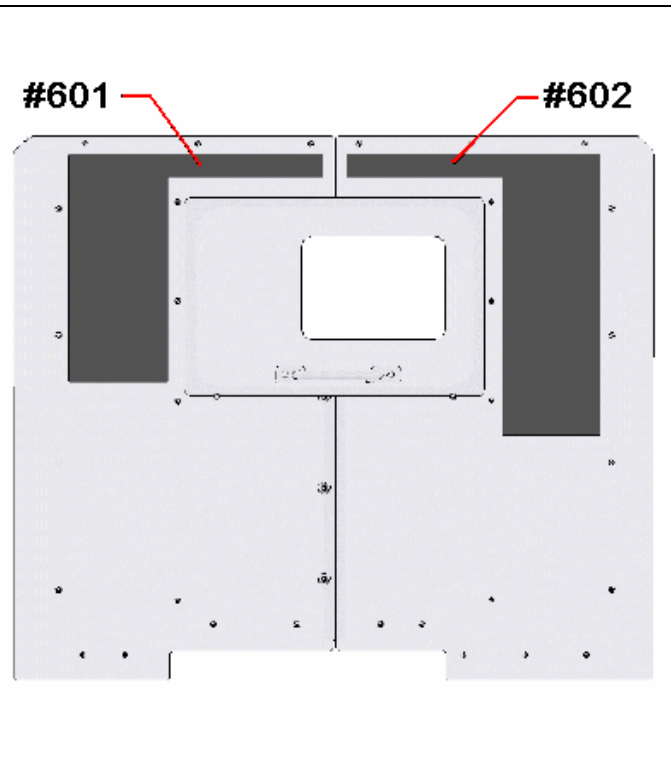
<b>Fasteners:</b>				
<b>Find No. (Table 6.2)</b>	<b>Part No.</b>	<b>Description</b>	<b>Size</b>	<b>Quantity</b>
None				
<b>Special Tools/ Materials</b>				
<b>Description:</b>		<b>Vendor/Part-Number:</b>		
None				

### 5.22.2 Installation Instructions

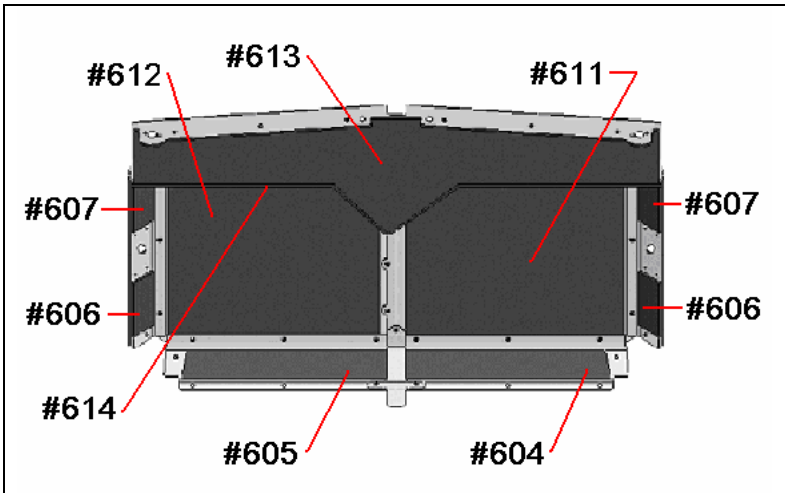
1. Prepare all surfaces to receive the foam insulation panels by cleaning the surfaces with a mild detergent. Allow them to dry before installing the foam.
2. Installation order is not critical.
3. Select a piece of foam insulation. Peel the plastic backing from the foam adhesive side. Align the foam with the surface to be covered. Place one edge of the foam on the surface to be covered and apply pressure, working across the foam in a continuous direction to minimize wrinkles and air entrapment.
4. Repeat for each part.



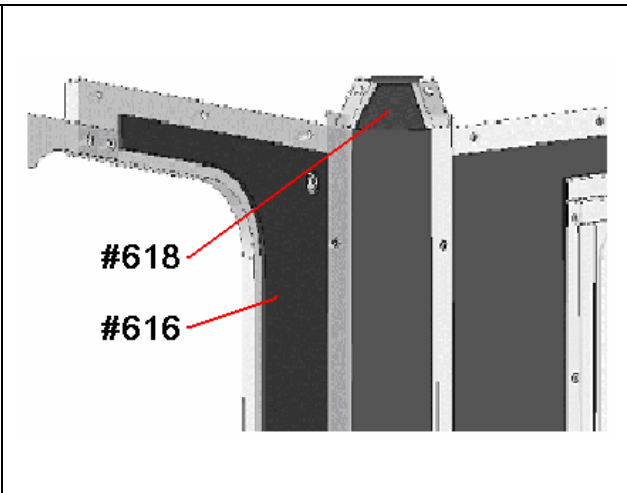
**Figure 5-118. Insulation Installation -  
 LH Side Wall Insulation (2 of 7).**



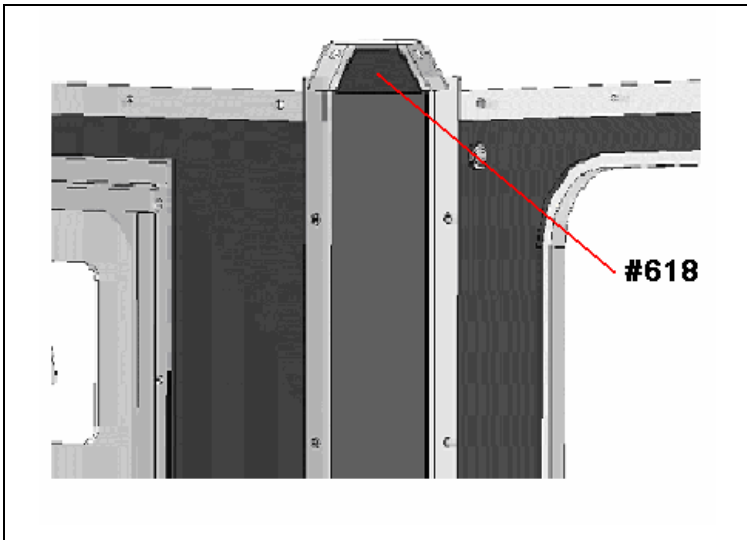
**Figure 5-119. Insulation Installation -  
 Backside Insulation (3 of 7).**



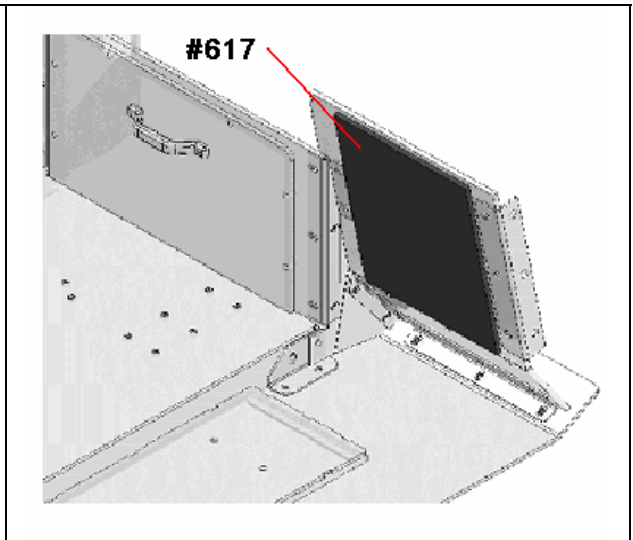
**Figure 5-120. Insulation Installation -  
Roof Insulation (4 of 7).**



**Figure 5-121. Insulation Installation -  
RH Corner Insulation (5 of 7).**



**Figure 5-122. Insulation Installation -  
LH Corner Insulation (6 of 7).**



**Figure 5-123. Insulation Installation -  
RH Front Insulation (7 of 7).**



## 5.23 Kit Installation Completion

### 5.23.1 Instructions

1. Loosen all bolts that were not previously treated with thread-locking compound. Apply thread-locking compound, reinstall, and tighten. The door hinge fasteners, wheel zone deflector fasteners, and windshield fasteners should have received the thread-locking compound prior to this procedure.
2. Re-install the dome (overhead interior cab) lights in the locations provided in each roof-to-side-panel overlaps. If necessary, the length of the wires may be extended by cutting each wire and splicing in a 6" section or wire with crimp connectors.
3. Install the windshield visors to the front roof armor. Use two each 1/4" x 3/4" countersunk screws (No. 15) for the outboard mounting of each visor. Use 2 each 1/4" x 3/4" button-head screws for each inboard catch. Note: There are different versions of the visors, and some may require the drilling of additional holes in the visor mount for installation.
4. Re-install the transmission shift selector support (shift tower) to the center floor armor panel using the original attachment fasteners. Ensure that the electrical connector is reconnected and tightened.

Note: For M915-A2 models, refer to Step 7.5 for Transmission Shift Tower installation instructions. For M916-A1 models, refer to Step 7.6 for Transmission and Transfer Case Shifter installation instructions.

5. Re-install the fire extinguisher and artic heater box to the center floor armor panel. Holes for attachment are provided as shown in Figure 5-124.
6. Splice the electrical wires for the exterior mirrors on each door using the supplied crimp connectors. Apply electrical tape over the spliced areas.
7. Trim the engine cowl (hood) to provide clearance around the cowl armor. The trim line should allow at least 3/8" clearance between the edge of the cowl and the armor. Ensure a generous radius as the cut line transitions from the longitudinal to lateral direction.

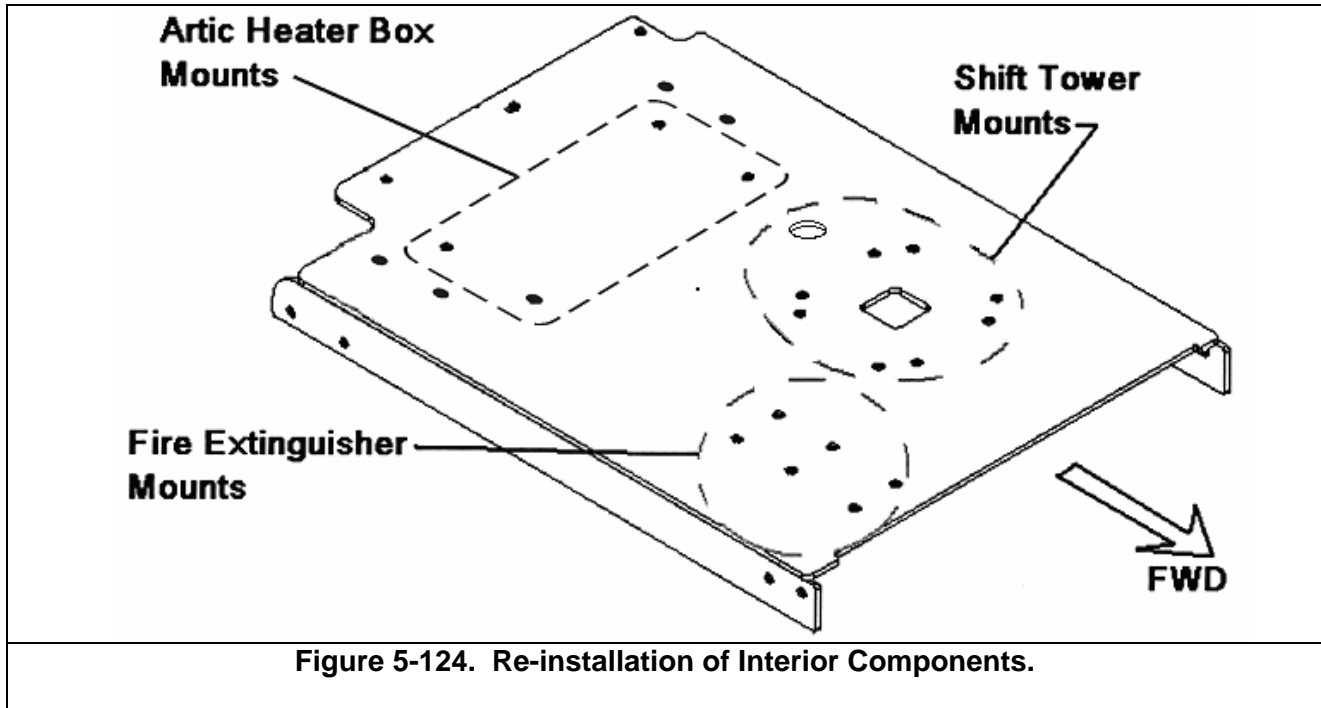


#### **WARNING**

Hood trim must be done in a well-ventilated area. Use an appropriate respirator during this operation. Failure to do so may result in personal injury.

8. Re-attach hood latches using original hardware.
9. Re-install windshield wipers using original hardware. Verify operation of the wipers over the proper windshield surface. Adjust wiper orientation as necessary.
10. It is recommended that the windshield area be leak checked by pouring water over the windshield area, particularly at the top around the interface between the cab and the windshield surrounds. Observe the interior windshield area for water leakage.

11. For M915-A2 and M916-A1 models, refer to Step 7.8 for installation of the engine check bracket.
12. For M915-A2 and M916-A1 models, refer to Step 7.7 for rear wall mounting plate installation instructions.



## 6. Fasteners

This chapter assists in identification and selection of the required fasteners used during the installation procedure.

### 6.1 Definitions of Maximal Initial Torque

Basic Assumptions:

All fasteners are zinc plated @ 0.125 Friction Coefficient  
 All fasteners are HEX head @ Grade 8

Table 6-1. Recommended Maximum Torque Values			
Diameter	Thread	Grade 8 Torque-	
		ft-lb	N-m
3/16" (5 mm)	NC	3	4
	NF	3	4
1/4"	NC	9	12
	NF	10	14
5/16"	NC	18	24
	NF	20	27
3/8"	NC	35	47
	NF	35	47
7/16"	NC	55	75
	NF	60	81
1/2"	NC	80	108
	NF	90	122
9/16"	NC	110	149
	NF	130	176
5/8"	NC	170	231
	NF	180	244
3/4"	NC	280	380
	NF	320	434
7/8"	NC	460	624
	NF	500	678
1"	NC	680	922
	NF	740	1,003

## 6.2 Fastener Maps

Refer to Table 3-5 for definition of the fasteners called out in this section.

### 6.2.1 Cab Support Reinforcement

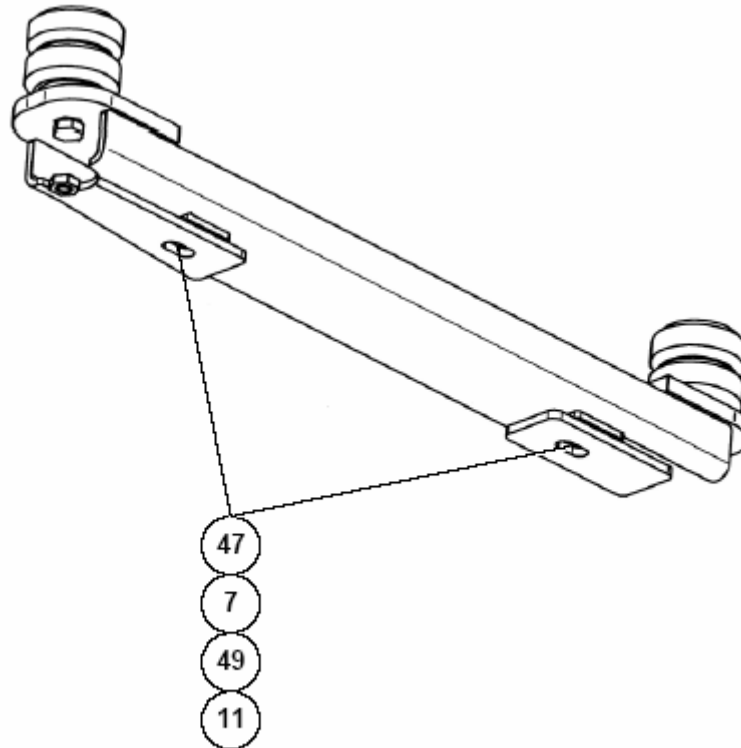


Figure 6-1. Fasteners Map - Cab Support Reinforcement.

### 6.2.2 RH & LH Wheel Housings

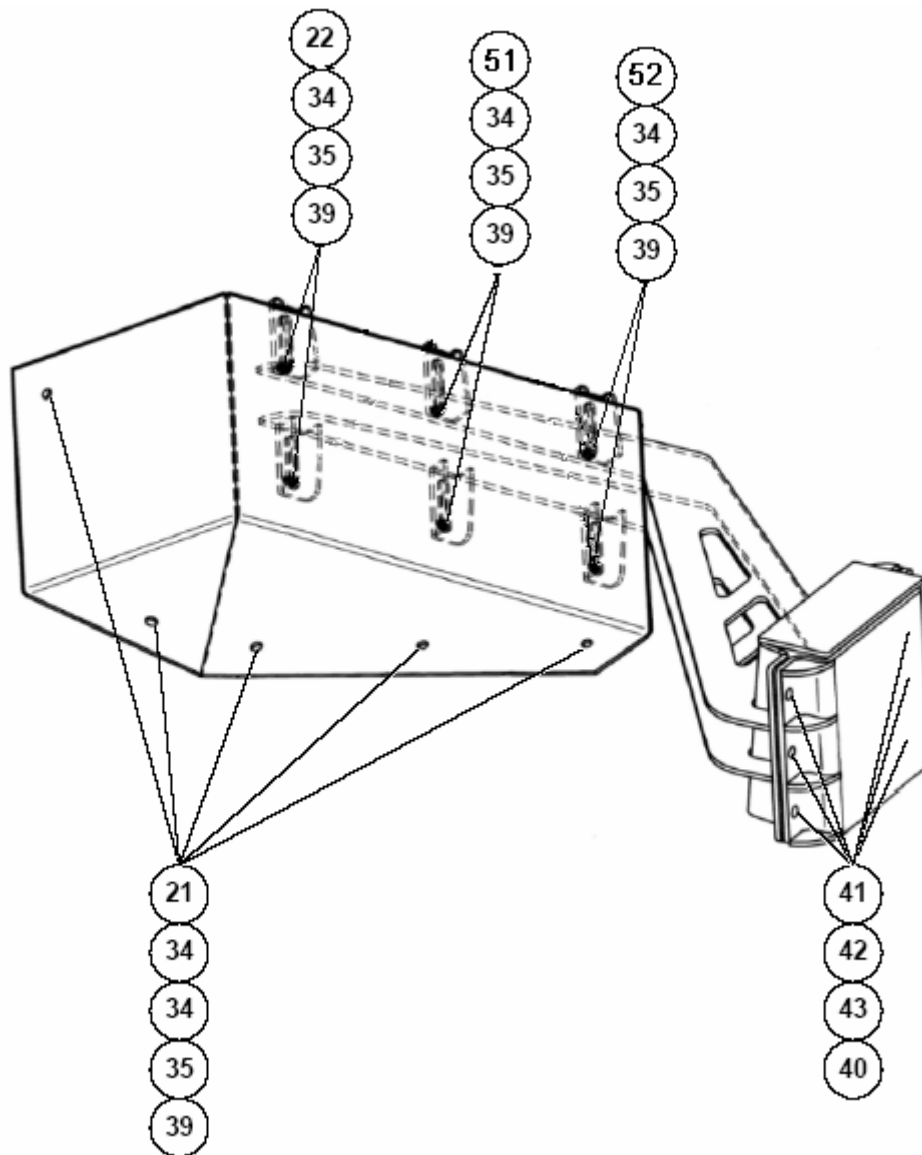


Figure 6-2. Fasteners Map - RH and LH Wheels Housing.

### 6.2.3 Floor and Firewall

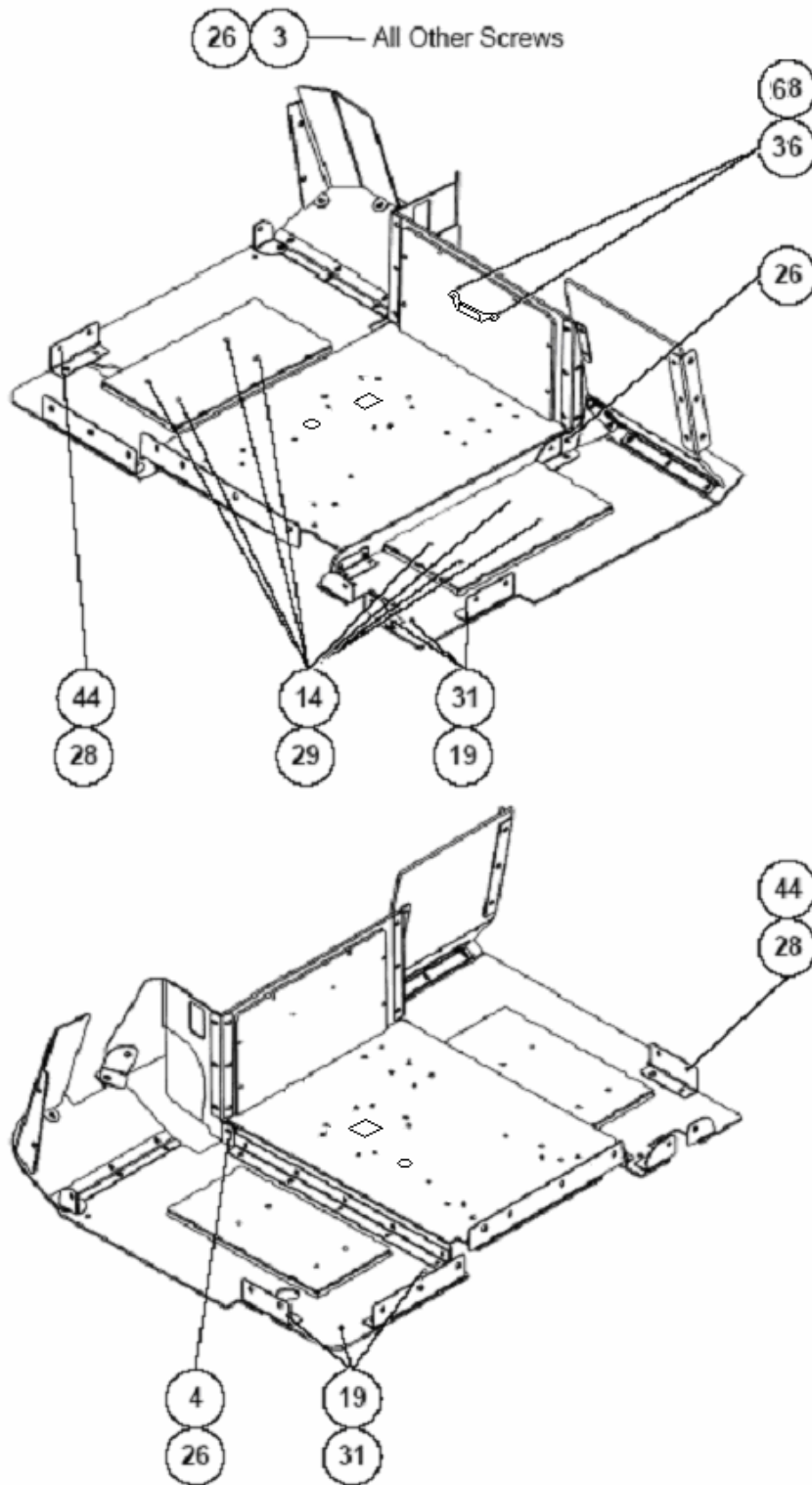


Figure 6-3. Fasteners Map - Floor and Firewall.

### 6.2.4 Right and Left Sides

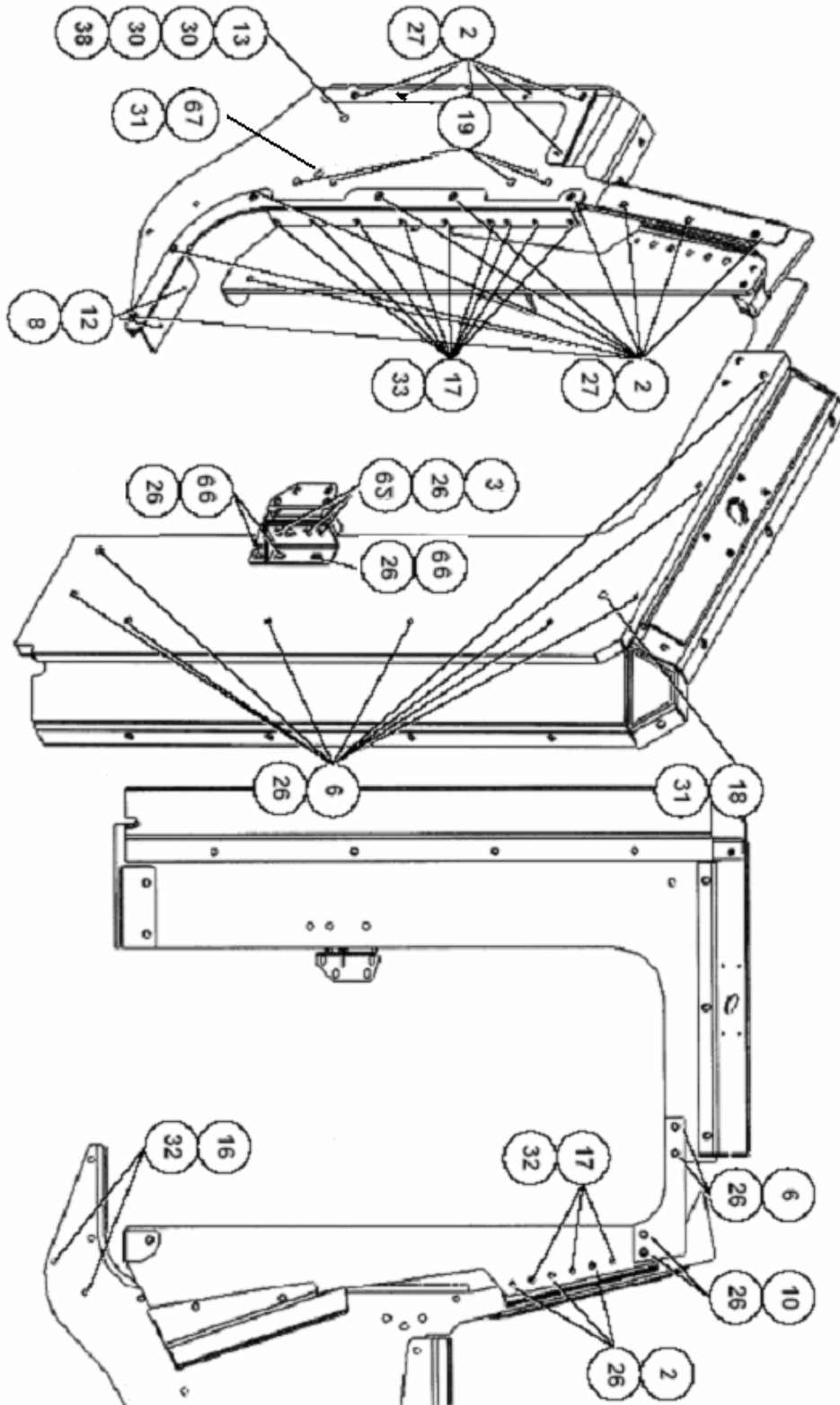


Figure 6-4. Fasteners Map - RH and LH sides.

### 6.2.5 Backside

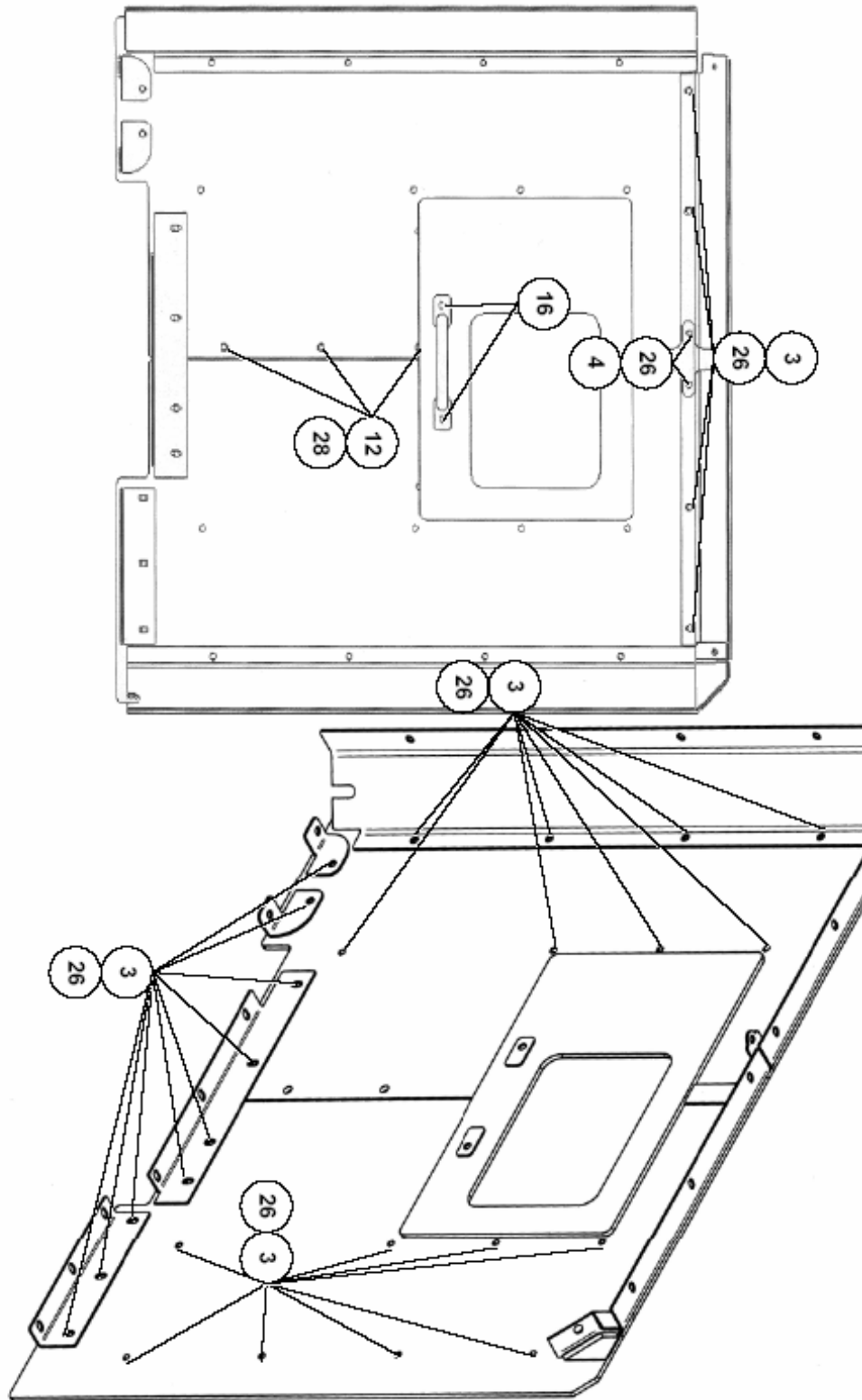


Figure 6-5. Fasteners Map – Backside.



### 6.2.6 Roof

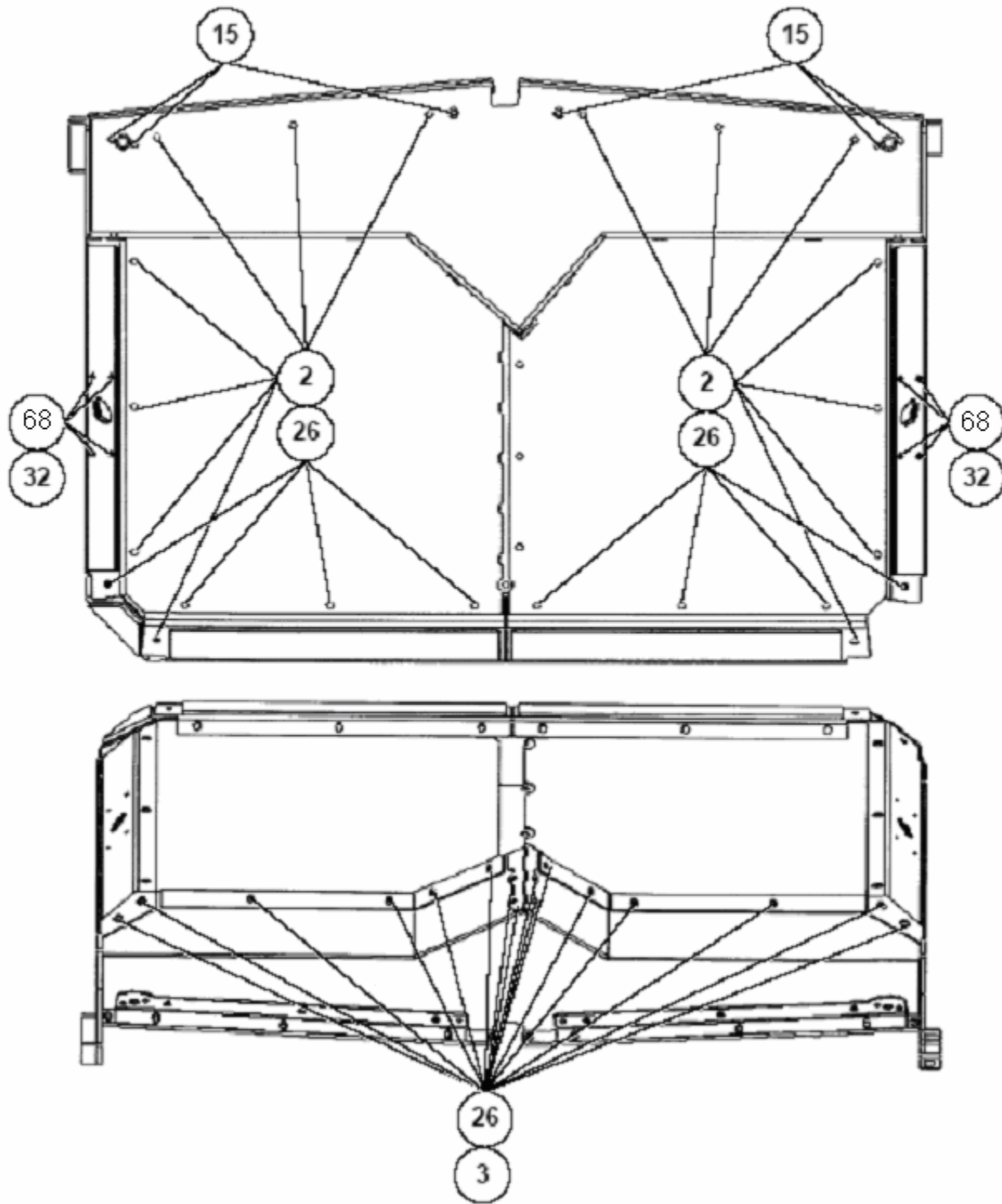


Figure 6-6. Fasteners Map – Roof.

### 6.2.7 Windscreen and Front Cover

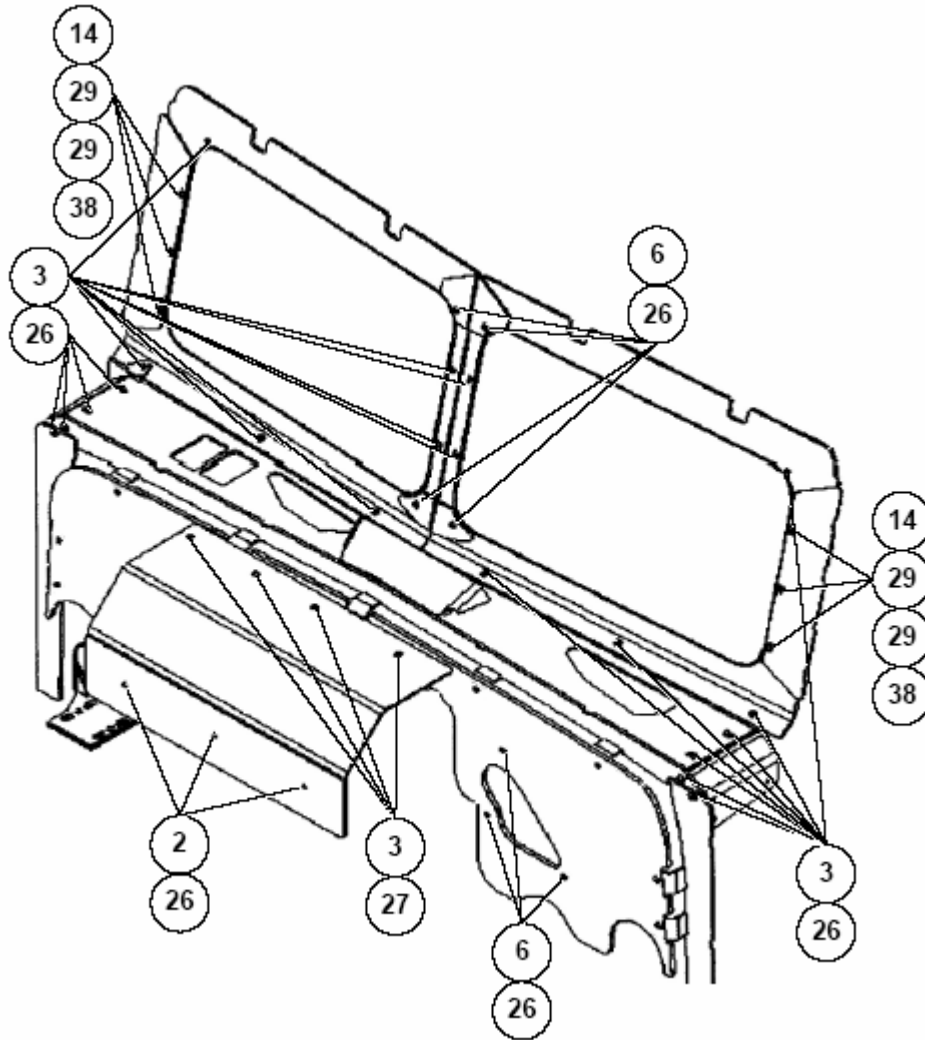
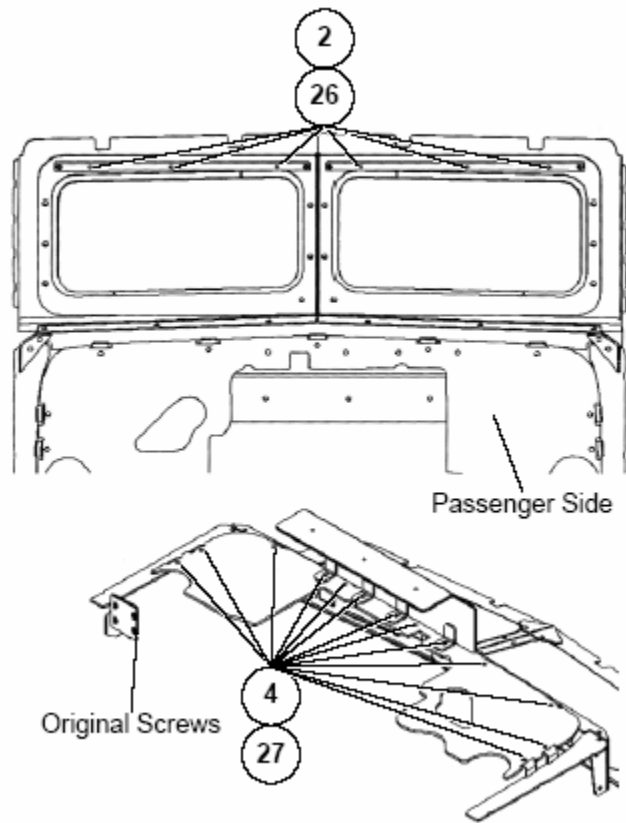


Figure 6-7. Fasteners Map - Windscreen and Front Cover (1 of 2).



**Figure 6-8. Fasteners Map - Windscreen and Front Cover (2 of 2).**

### 6.2.8 Left and Right Doors

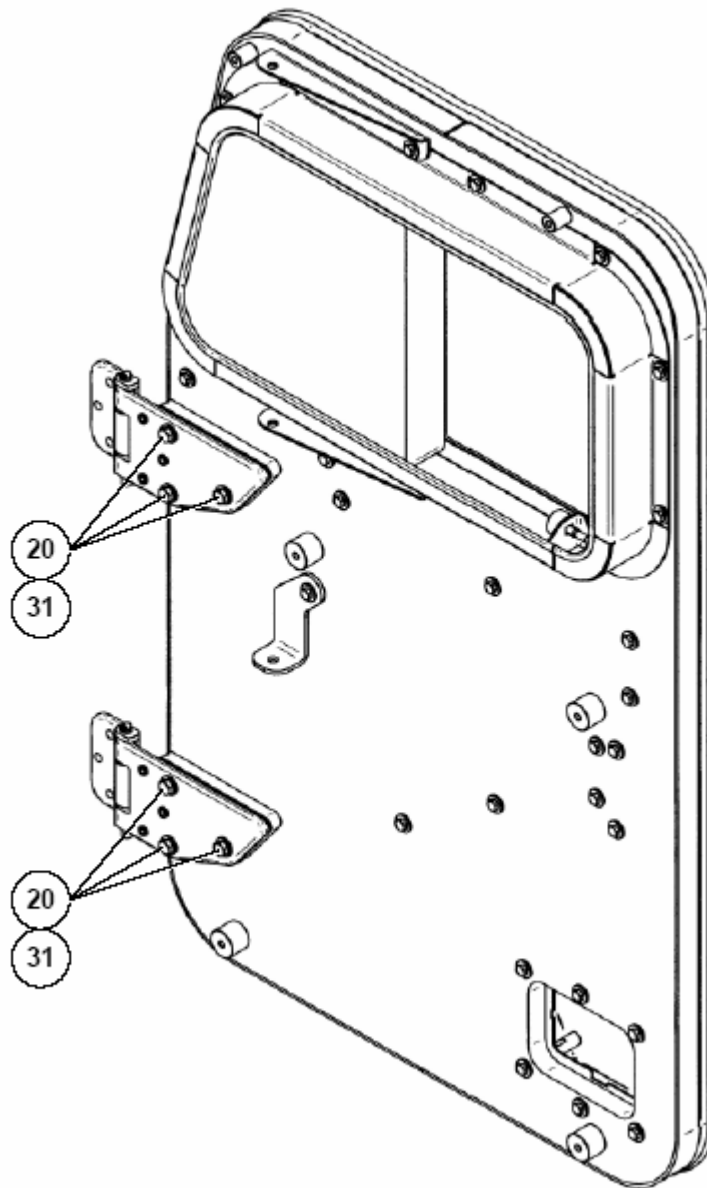


Figure 6-9. Fasteners Map - RH and LH Doors.

## 7. M915-A2 and M916-A1 Specific Installation Steps

This chapter provides additional and replacement instructions, accompanied with illustrations, on how to install certain kit subassemblies for the M915-A2 and M916-A1 that differ in design from the M915-A3 models. Instructions should be followed in the sequence described in Chapter 5 with the steps contained within this chapter substituted were specified.

In order to install the Crew Kit 0257000000-00 (113500-1) on the M915-A2 or M916-A1, the installer will also need the M915-A2 and M916-A1 Adaptation Kit, 113502-1. Its contents are described in Table 3.4.

### 7.1 Prep work for Cab Support installation (M916-A1 Only)

Perform this step prior to Step 5.1 in the main installation sequence.

#### 7.1.1 Parts, Fasteners, Special Tools, and Materials

<b>Parts</b> (see Figure 7-2, 7-3, and 7-4):				
<b>Part No.</b>	<b>Alternate Part No.</b>	<b>Description</b>	<b>Find No. in Procedure</b>	<b>Quantity</b>
113508-1		Strap, Hose Support	#508	1
0093200		Wrap, Hose	#200	3 ft
<b>Fasteners:</b> (see Figure 7-4)				
<b>Find No. (Table 3-5)</b>	<b>Description</b>		<b>Size</b>	<b>Quantity</b>
57	Screw, Button Head Cap		1/4" x 1"	2
62	Nut, Self-locking, NC		1/4"	2
<b>Special Tools:</b>				
<b>Description</b>		<b>Vendor/Part-Number</b>		
Standard pipe wrench				

#### 7.1.2 Installation Instructions

1. Disconnect the P-clips that hold the low-pressure hydraulic hoses that feed the pump located on the transmission (These hoses are indicated in Figure 7-1).
2. Turn the low-pressure hydraulic line elbows connected to the pump on the transmission in a clockwise fashion (tightening) up to 1/8 turn to achieve more clearance under the hoses for the cab support (see Figure 7-1). Access to these elbows is best achieved through the removable panel on the floor beneath the shift tower.
3. Install 8" to 9" of protective hose wrap part # 200 to each hose in the area indicated in Figure 7-2. After the cab support is installed, the position of the wrap may be adjusted to provide protection against wear from the support.

4. Install 8” to 9” of protective hose wrap part # 200 to each hose in the area indicated in Figure 7-3. The wrap should start just aft of the P-clips.
5. Install the Cab Support per Step 5.1 in the main installation manual P/N 0257550622-00.
6. Reconnect the P-clips that were disconnected in Step 1 using the strap support part #508 (see Figure 7-4). The strap support allows for the adjustment of the spacing between the upper and lower set of P-clips. This spacing should be set to minimize the potential for the hose to wear or rub on the frame or cab components.

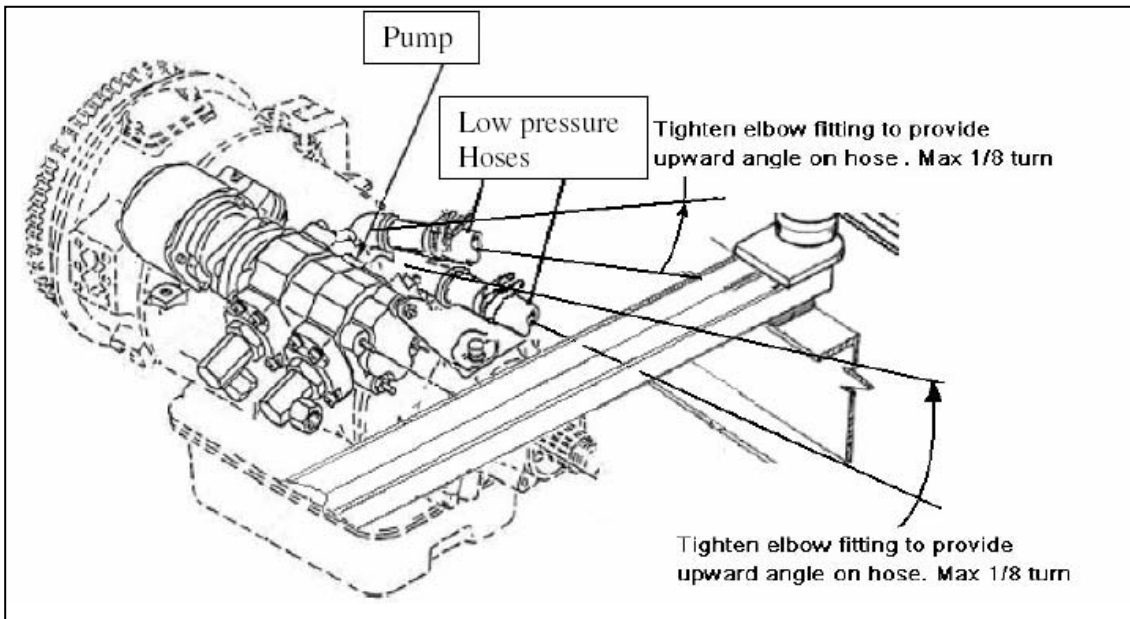


Figure 7-1. Elbow Adjustment.

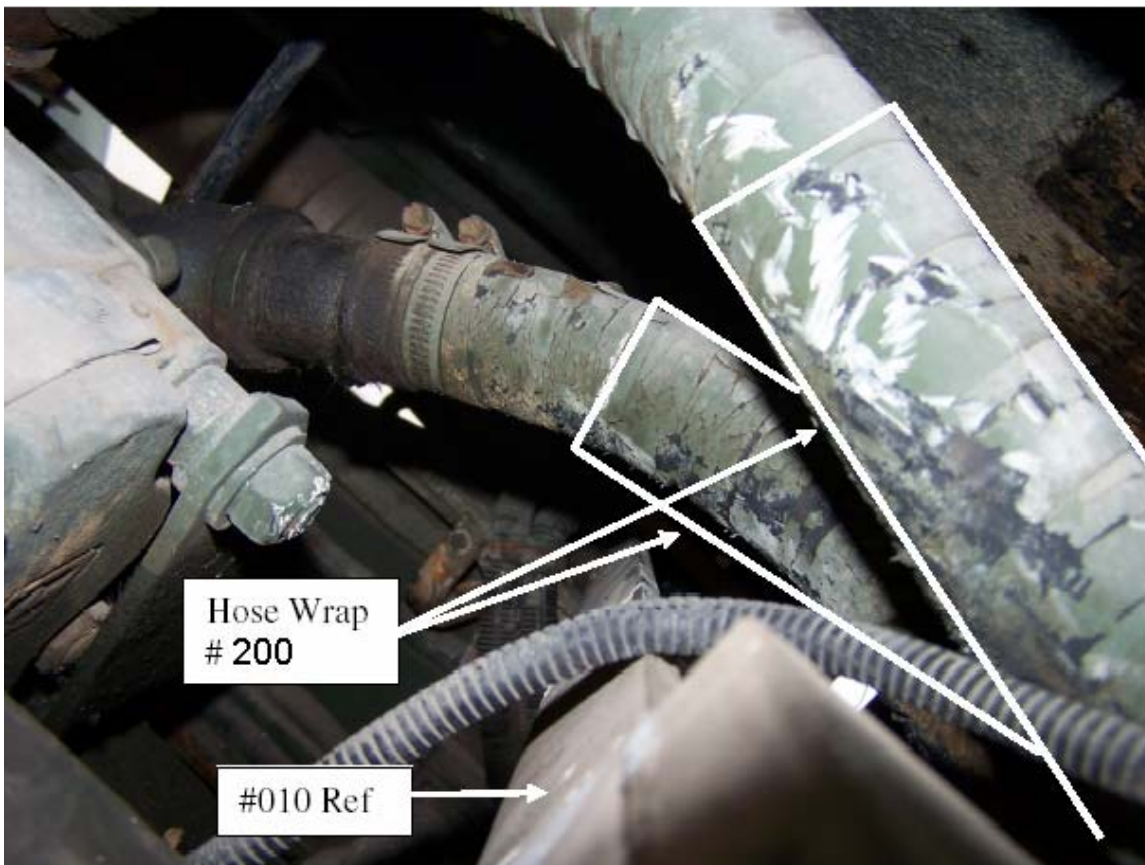


Figure 7-2. Hose Wrap Location.

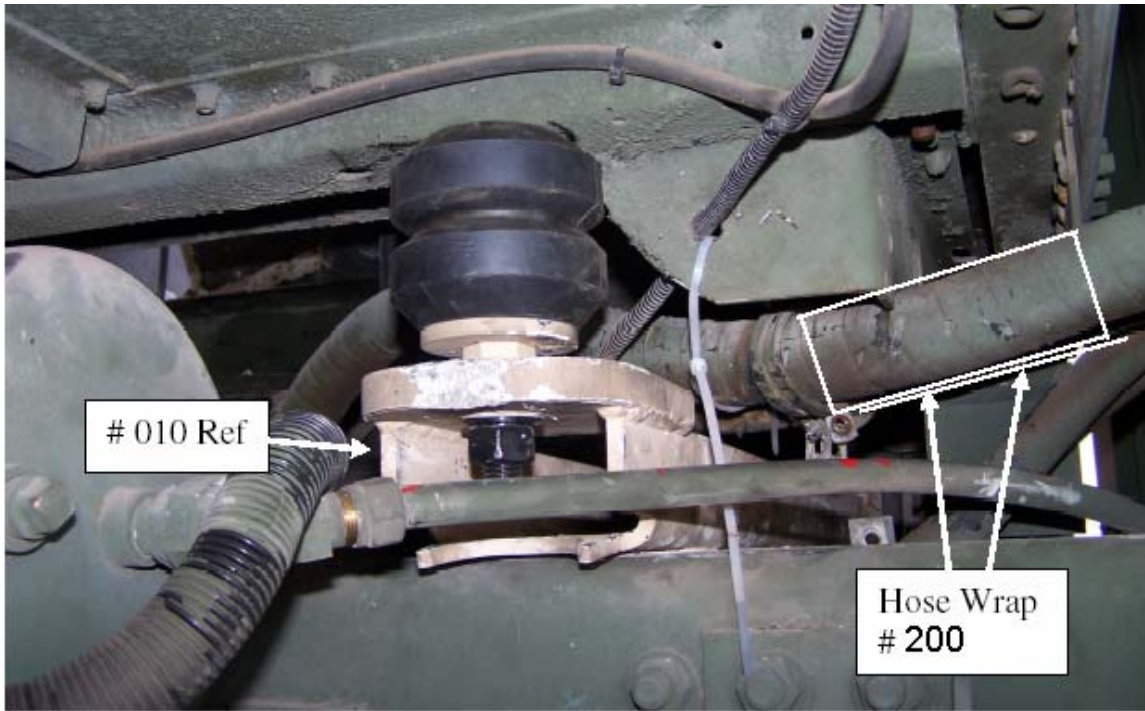


Figure 7-3. Hose Wrap Location.

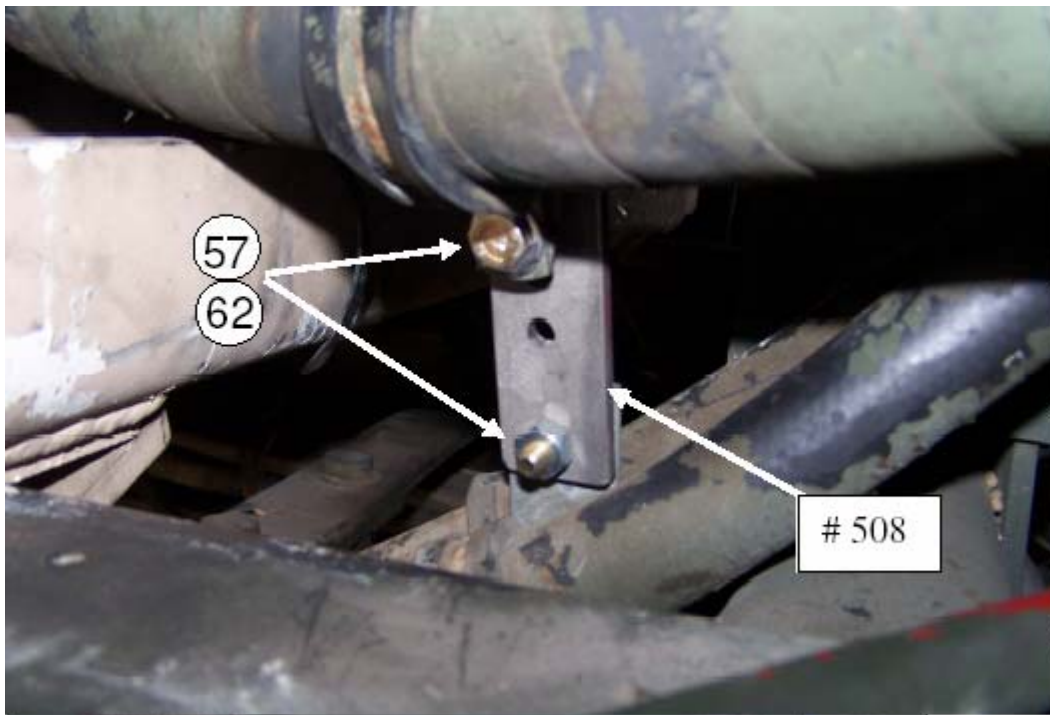


Figure 7-4. Strap Installation.



## 7.2 Hood Spacer Installation (M915-A2 and M916-A1)


Perform this step prior to Step 5.2 in the main installation sequence.

### 7.2.1 Parts, Fasteners, Special Tools, and Materials

Parts (see Figure 7-5):				
Part No.	Alternate Part No.	Description	Find No. in Procedure	Quantity
0257140642-00	113512-1	SPACER, HOOD	#642	2
Fasteners: (see Figure 7-5)				
Find No. (Table 3-5)	Description	Size	Quantity	
52	Bolt	1/2" x 3-1/2"	2	
34	Flat Washer	1/2"	4	
63	Self-Locking Nut, NC	1/2"	2	
Special Tools:				
Description		Vendor/Part-Number		
None				

### 7.2.2 Installation Instructions

- 1) Remove the bolt that attaches each hood hinge to the front cross member. Using an appropriate lifting device, lift the hood and insert one spacer, P/N 113512-1, under each hinge. Re-attach using 1/2" x 3-1/2" bolts, 1/2" flat washers, and 1/2" locknuts. Torque to 122 Nm (90 lb-ft) (See Figure 7-5).

	<p><b>IMPORTANT</b></p> <p>The hinges have slotted holes to adjust the hood forward or rearward. Install the hood initially in its forward-most position and then re-adjust to allow for best fit and engagement with the hood clamps after the entire kit has been installed.</p>
---	--

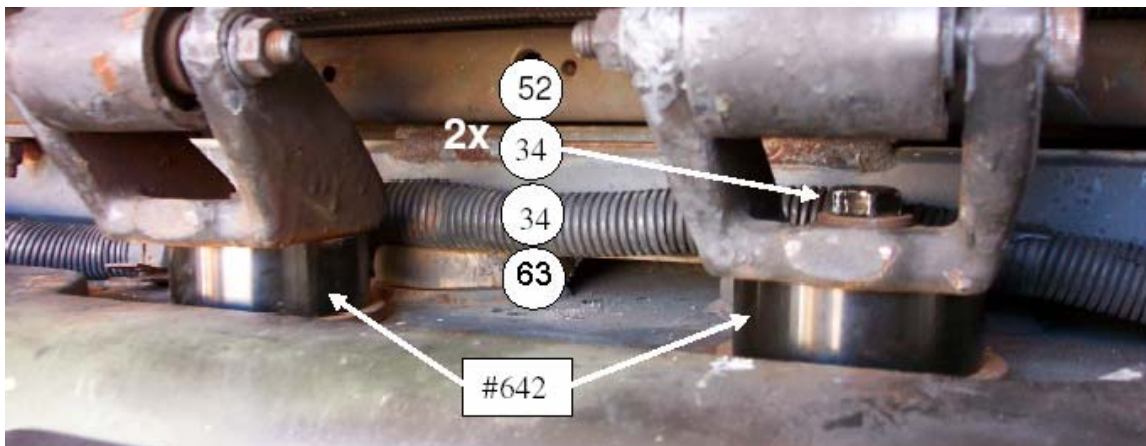


Figure 7-5. Hood Spacer.

## 7.3 Installation of the LH Wheel Housing (M915-A2 and M916-A1)

Replace Steps 5.2 and 5.3 in the main installation sequence with this step and Step 7-4.

### 7.3.1 Parts, Fasteners, Special Tools, and Materials

<b>Parts</b> (see Figure's 7-6,7-7,7-8 and 7-9):				
<b>Part No.</b>	<b>Alternate Part No.</b>	<b>Description</b>	<b>Find No. in Procedure</b>	<b>Quantity</b>
0257970007-00		Wheel Zone Deflector, LH	#007	1
0257970659-00		Support, LH	#659	1
0257970971-00		Arm, WZD Support, LH	#971	1
0257970640-00	113513-1	Spacer, Wheel Zone Deflector	#640	2
0257970643-00	113513-3	Spacer, Wheel Zone Deflector	#643	2
G81900-0012		Wrap, Hose	#0012	.8 ft
<b>Fasteners</b> (see Figure's 7-6,7-7 and 7-8)				
<b>Find No.</b>	<b>Description</b>	<b>Size (P/N in Procedure - last 3 digits)</b>	<b>Quantity</b>	
51	Bolt	1/2" x 2-1/2"	2	
52	Bolt	1/2" x 3-1/2"	2	
22	Bolt	1/2" x 1-3/4"	2	
41	Bolt	5/8" x 2-1/2"	6	
35	Star-Washer	1/2"	6	
42	Star-Washer	5/8"	6	
34	Flat-Washer	1/2" x 1" x 1/8"	12	
43	Flat-Washer	5/8" x 1-1/4" x 1/8"	6	
39	Nut	1/2"	6	
40	Nut	5/8"	6	
54	Bolt	5/8" x 2-3/4"	8	
55	Nut, Shoulder	5/8"	8	
<b>Special Tools:</b>				
<b>Description</b>		<b>Vendor/Part-Number</b>		
Lifting device capable of lifting approximately 110 kg (242 lb)		Commercial		

### 7.3.2 Installation Instructions

1. Remove the left-hand Sling/Lift bracket from the front of the bumper by removing its four attachment bolts.
2. Re-attach the Sling/Lift bracket with the #659 part sandwiched between it and the bumper using four 5/8" x 2-3/4" bolts, the eight existing 5/8" flat washers, and four 5/8 locknuts. Torque to 230 Nm (170 lb-ft). Note: Thread-locking compound must be used on these fasteners (See Figure 7-6).

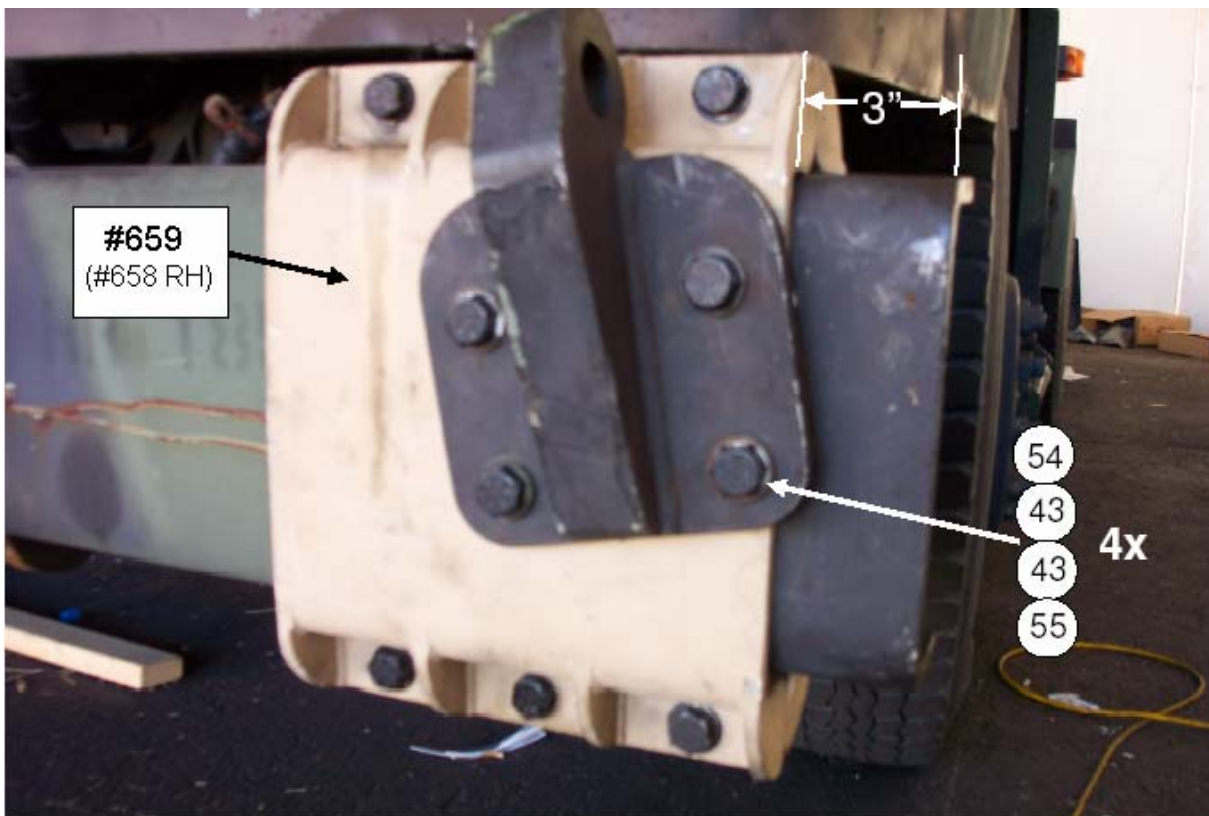


Figure 7-6. #659 Installation (#658 RH).

3. Install the LH Wheel Housing Support Arm part #971 to part #659 using six 5/8" x 2-1/2" bolts, 5/8" star washers, and 5/8" flat washers inserted in that order through the front of part #659 and four 5/8" nuts on the back side of part #971. The center two bolts will thread directly into part #971 without the need for nuts. Torque to 230 Nm (170 lb-ft). Note: Thread-locking compound must be used on these fasteners.

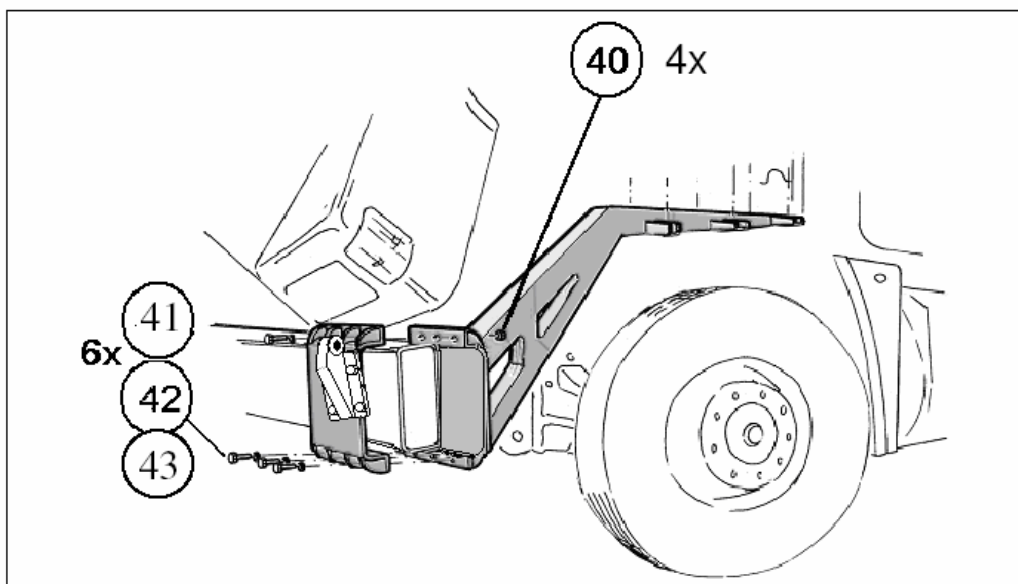


Figure 7-7. Wheel Housing Support Arm.

4. Lift part #007 into position as shown in Figure 7-8. Insert the aft-most bolts (Item 22). Temporarily use the aft fasteners to hold the deflector in position. Install the center and forward fasteners next with the 113513-3 and 113513-1 spacers respectively (do not tighten the bolts until all fasteners are in place). Apply thread-locking compound to the bolts. Install the hardware in the following order:
  - Star Washer
  - Flat Washer
  - Insert bolt from beneath through assembled parts
  - Flat Washer
  - Nut.
5. Tighten bolts to a 122-Nm (90 lb-ft) torque.
6. Ensure that the flexible brake lines are not rubbing on the inside lower edge of the wheel zone deflector (#007). If the lines are rubbing near the Wheel Zone Deflector, it may be possible to relocate them by loosening the hose end fitting, twisting the lines slightly, and then re-tightening the hose end fittings.
7. Apply protective hose wrap to the flexible brake lines in the area shown in Figure 7-9.



**IMPORTANT**

Raise the rear end of part #971 as high as possible before connecting with part #967. Use the same procedure with #970 and #658 when installing the right hand wheel housing.

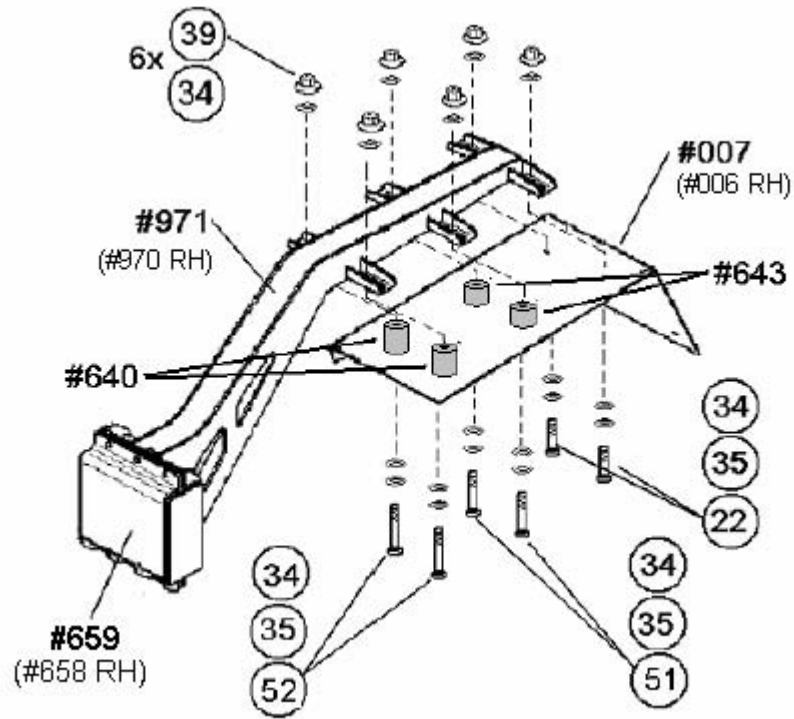


Figure 7-8. Wheel Housing.

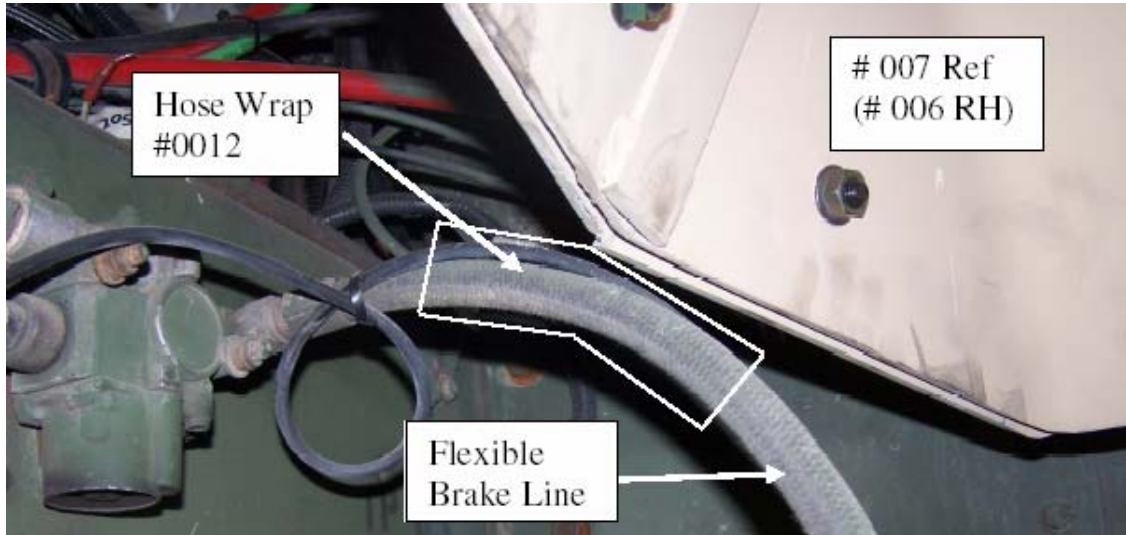


Figure 7-9. Hose Wrap Location.

## 7.4 Installation of the RH Wheel Housing (M915-A2 and M916-A1)

Installation steps of the Right-Hand side are identical to the Left-Hand side using the parts in 7.4.1 and Figures 7-6 thru 7-9 as reference.

### 7.4.1 Parts, Fasteners, Special Tools, and Materials

<b>Parts</b>				
<b>Part No.</b>	<b>Alternate Part No.</b>	<b>Description</b>	<b>Find No. in Procedure</b>	<b>Quantity</b>
0257970006-00		Wheel Zone Deflector, RH	#006	1
0257970658-00		Support RH	#658	1
0257970970-00		Arm, WZD Support, RH	#970	1
0257970640-00	113513-1	Spacer, Wheel Zone Deflector	#640	2
0257970643-00	113513-3	Spacer, Wheel Zone Deflector	#643	2
G81900-0012		Wrap, Hose	#0012	.8 ft
<b>Fasteners</b>				
<b>Find No.</b>	<b>Description</b>	<b>Size (P/N in Procedure - last 3 digits)</b>	<b>Quantity</b>	
51	Bolt	1/2" x 2-1/2"	2	
52	Bolt	1/2" x 3-1/2"	2	
22	Bolt	1/2" x 1-3/4"	2	
41	Bolt	5/8" x 2-1/2"	6	
35	Star-Washer	1/2"	6	
42	Star-Washer	5/8"	6	
34	Flat-Washer	1/2" x 1" x 1/8"	12	
43	Flat-Washer	5/8" x 1-1/4" x 1/8"	6	
39	Nut	1/2"	6	
40	Nut	5/8"	6	
54	Bolt	5/8" x 2-3/4"	8	
55	Nut, Shoulder	5/8"	8	
<b>Special Tools:</b>				
<b>Description</b>		<b>Vendor/Part-Number</b>		
Lifting device capable of lifting approximately 110 kg (242 lb)		Commercial		

## 7.5 Shift Tower Installation (M915-A2 Only)

This procedure may be performed anytime after step 5.4 in the installation process.

### 7.5.1 Parts, Fasteners, Special Tools, and Materials

<b>Parts</b> (see Figure 7-10):				
<b>Part No.</b>	<b>Alternate Part No.</b>	<b>Description</b>	<b>Find No. in Procedure</b>	<b>Quantity</b>
113511-1		Adapter, Shift Tower	#511	1
<b>Fasteners:</b> (see Figure 7-10)				
<b>Find No. (Table 3-5)</b>	<b>Description</b>	<b>Size</b>	<b>Quantity</b>	
4	Bolt (these bolts were temporarily used in step 5)	5/16" x 1-1/4"	5	
25	Flat Washer	5/16"	5	
56	Screw, Button Head Cap	1/4" x 1/2"	8	
32	Flat Washer	1/4"	8	
<b>Special Tools:</b>				
<b>Description</b>		<b>Vendor/Part-Number</b>		

### 7.5.2 Installation Instructions

1. Bolt the shift tower adapter #511 to the Center Floor Armor # 815.
2. Feed the shifter cable up through the square hole in the center floor panel and the adapter plate. Re-attach the shift cable to the shift tower and bolt the shift tower to the shift tower adapter part #511 (see Figure 7-10). Apply thread-locking compound to the screws.

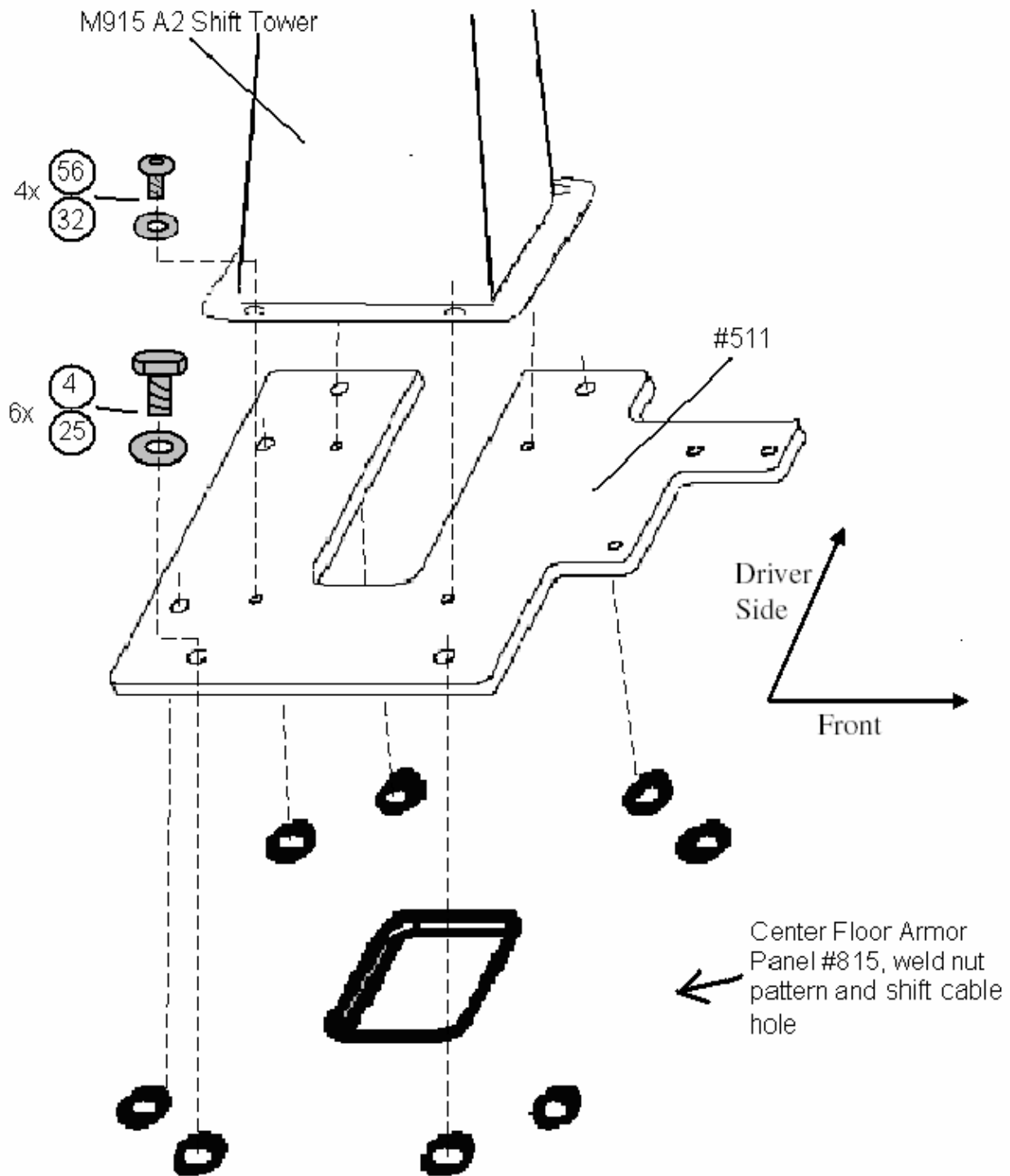


Figure 7-10. Shift Tower Installation.



## 7.6 Shift Tower Installation (M916-A1 Only)

This procedure may be performed anytime after Step 5.4 in the installation process.

### 7.6.1 Parts, Fasteners, Special Tools, and Materials

<b>Parts</b> (see Figure 7-11):				
<b>Part No.</b>	<b>Alternate Part No.</b>	<b>Description</b>	<b>Find No. in Procedure</b>	<b>Quantity</b>
113509-1		Adapter, Shift Tower	#509	1
<b>Fasteners:</b> (see Figure 7-11)				
<b>Find No. (Table 3-5)</b>	<b>Description</b>	<b>Size</b>	<b>Quantity</b>	
4	Bolt (these bolts were temporarily used in step 5)	5/16" x 1-1/4"	5	
25	Flat Washer	5/16"	5	
56	Screw, Button Head Cap	1/4" x 1/2"	8	
32	Flat Washer	1/4"	8	
<b>Special Tools:</b>				
<b>Description</b>		<b>Vendor/Part-Number</b>		

### 8.6.2 Installation Instructions

1. Bolt the shift tower adapter #509 to the Center Floor Armor # 815.
2. Feed the shifter cable up through the modified square hole in the center floor panel and the adapter plate. Re-attach the shift cable to the shift tower and bolt the shift tower to the shift tower adapter part #509 (see Figure 7-11). Apply thread-locking compound to the screws.
3. Feed the transfer case cable up through the hole cut in the center floor panel #815 and adapter plate #509. Re-attach the transfer case cable to the transfer case shifter and fasten the shifter (not shown) to the adapter plate part #509 using the four holes indicated in Figure 7-11 and four more Screws 56 and Flat washers 32. Apply thread-locking compound to the screws.

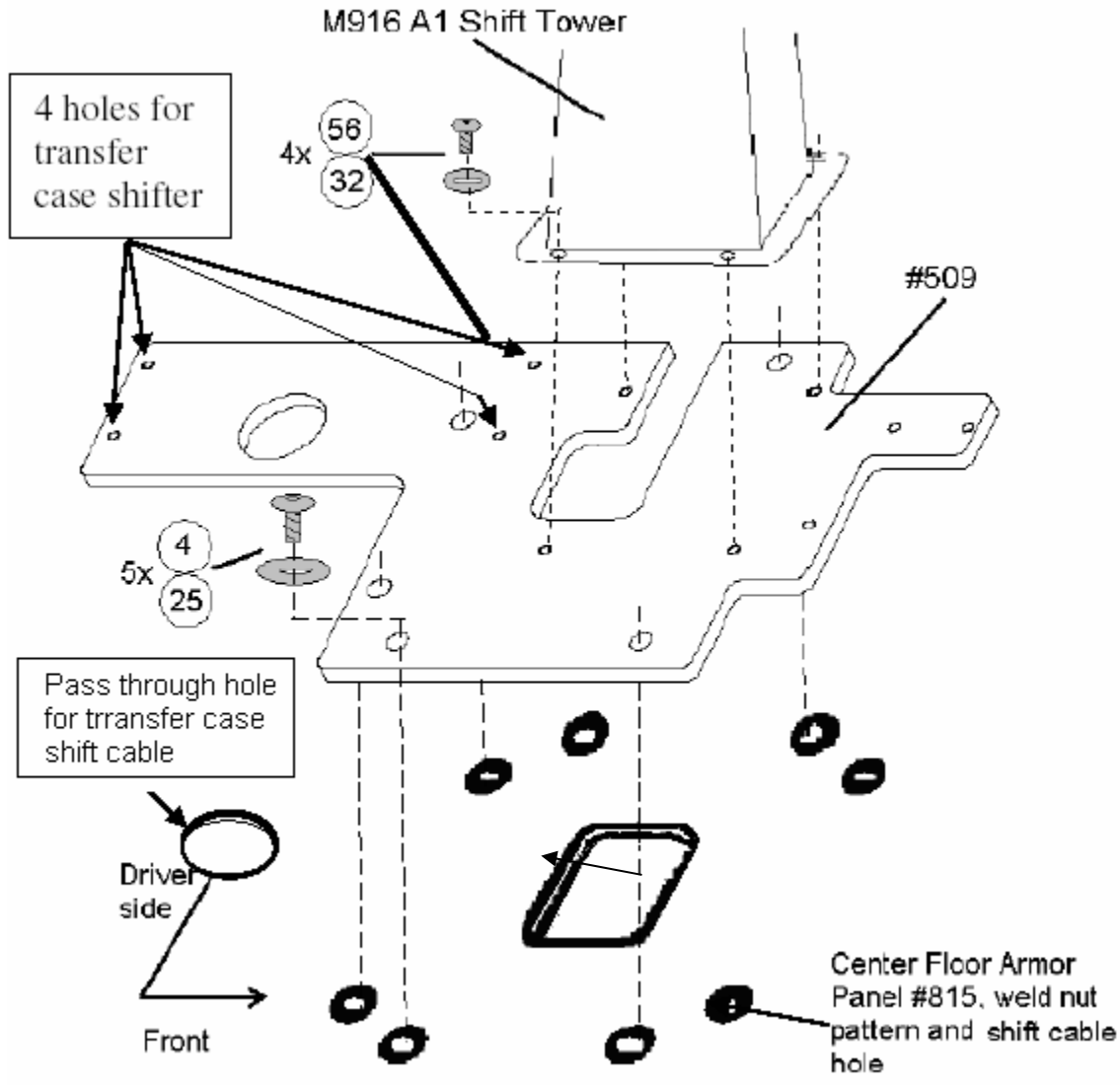


Figure 7-11. Shift Tower Installation (M916-A1).

## 7.7 Rear Wall Mounting Plate (M915-A2 and M916-A1)

This step should be performed after Step 5-11 and prior to Step 5-17 in the main installation sequence.

### 7.7.1 Parts, Fasteners, Special Tools, and Materials

<b>Parts</b> (see Figure 7-12):				
<b>Part No.</b>	<b>Alternate Part No.</b>	<b>Description</b>	<b>Find No. in Procedure</b>	<b>Quantity</b>
113507-1		Plate, Mounting	#507	1
<b>Fasteners:</b> (see Figure 7-12)				
<b>Find No. (Table 3-5)</b>	<b>Description</b>		<b>Size</b>	<b>Quantity</b>
4	Bolt		5/16" x 1-1/4"	6
58	Screw, self tapping		#10	16
<b>Special Tools:</b>				
<b>Description</b>		<b>Vendor/Part-Number</b>		
No 21 drill bit (0.159" Diameter)				

### 8.7.2 Installation Instructions

1. Remove the six bolts indicated in Figure 7-12 and install part #507 using new bolts (4) and existing washers. Apply thread-locking compound to the screws.
2. Original Equipment Manufacturer (OEM) components that were displaced from the rear wall may now be mounted to this plate. Simply transfer the mounting hole pattern for each component to the plate and drill a 0.159" (No. 21) hole for each mark. Secure the component with #10 x 1/2" self tapping screws (58).

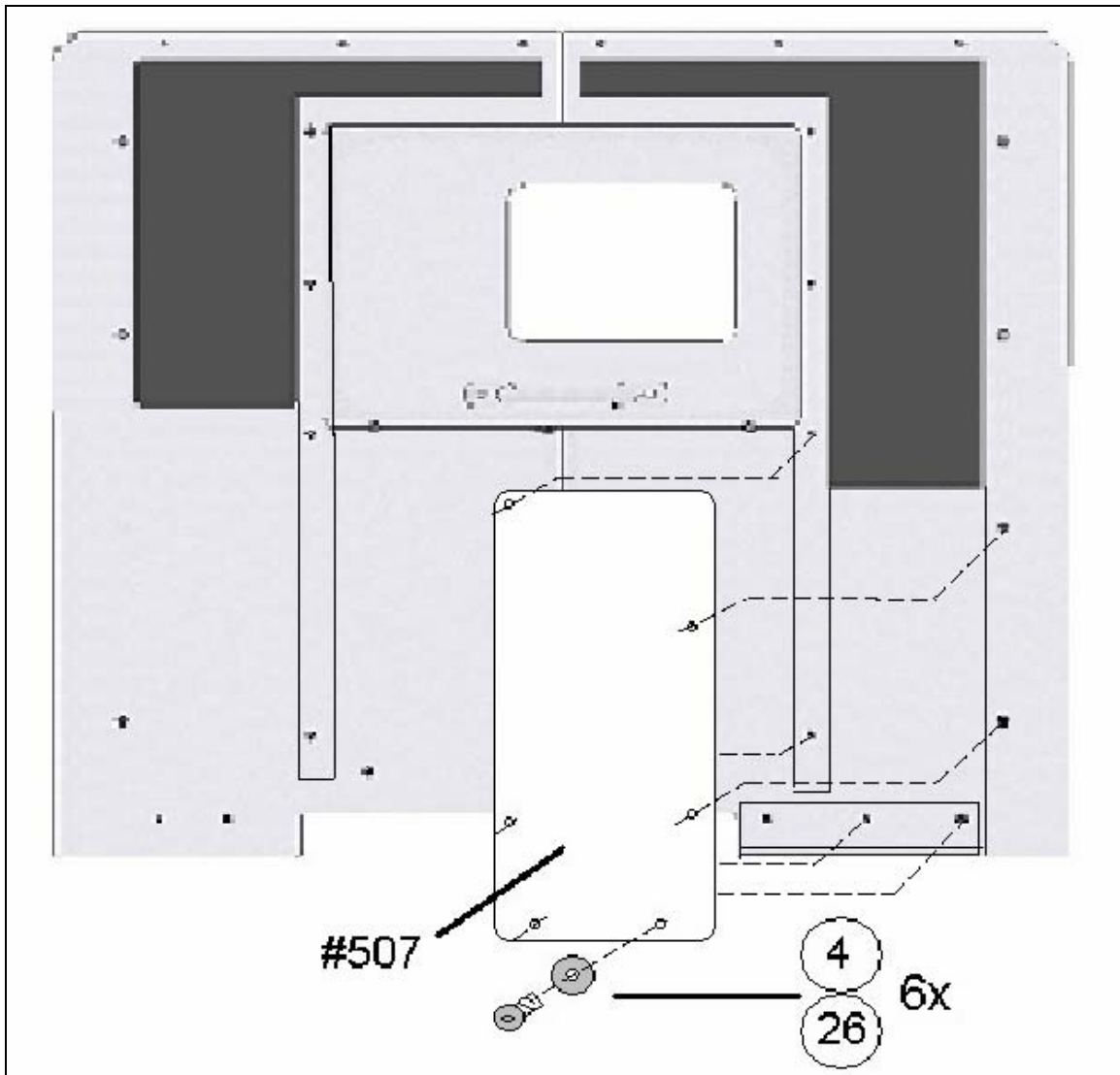


Figure 7-12. Mounting Plate Installation.

## 7.8 Relocate Engine Check Connector (M915-A2 and M916-A1)

This step can be performed after all of the steps the main installation sequence are completed.

### 7.8.1 Fasteners

Fasteners: (see Figure 7-13)			
Find No. (Table 3-5)	Description	Size	Quantity
59	Screw	#10 x 3/4"	1
60	Nut, Hex, Self Locking	#10	1
61	Flat Washer	#10	2

### 8.8.2 Installation Instructions

- 1) Drill a new 13/64" hole in the diagnostic switch bracket 1" to the left of the existing mounting hole (See Figure 7-13).
- 2) Thread the existing fastener through the new hole and mount the bracket through the lower dash cover to the support brace.
- 3) Drill a 13/64" hole up through the lower dash cover using the original mounting hole as a template.
- 4) Secure in this location with new fasteners provided (See Figure 7-13).

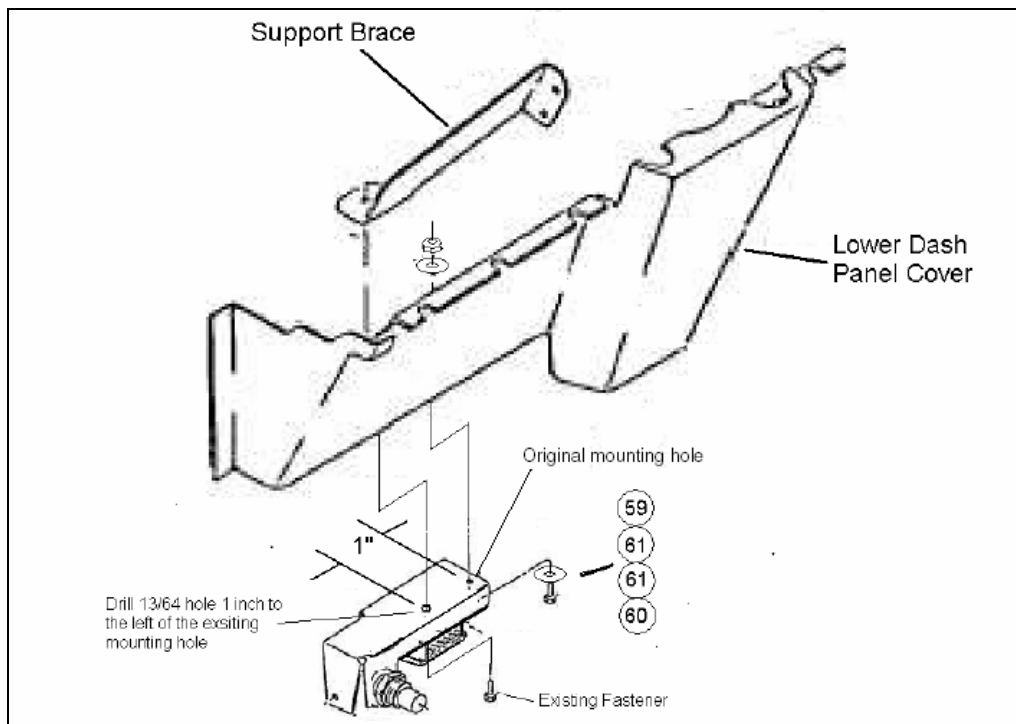


Figure 8-14. Engine Check Bracket Installation.



**FIELD MAINTENANCE (UNIT AND DIRECT SUPPORT MAINTENANCE) REPAIR PARTS AND SPECIAL TOOLS LISTS (RPSTL) INTRODUCTION**

0037 00

**SCOPE**

This RPSTL lists and authorizes spares and repair parts for performance of Field level maintenance of the M915A3P1 Truck, Tractor Line-Haul, M915A2P1 Truck, Tractor Line-Haul, M916A3P1 Truck, Tractor Light Equipment Transporter (LET), M917A2P1 Truck, Dump, Heavy Chassis, M915A4P1 Truck, Tractor Line-Haul, M917A1P1 Truck, Dump, Heavy Chassis, M916A1P1 Truck, Tractor Light Equipment Transporter (LET), and M916A2P1 Truck, Tractor Light Equipment Transporter (LET) Crew Protection Kit. It authorizes the requisitioning, issue, and disposition of spares and repair parts as indicated by the source, maintenance, and recoverability (SMR) codes.

**GENERAL**

In addition to the Introduction work package, this RPSTL is divided into the following work packages:

- a. **Repair Parts Lists Work Package.** Work package containing lists of spares and repair parts authorized by this RPSTL for use in the performance of maintenance. This work package also includes parts which must be removed for replacement of the authorized parts. Parts lists are composed of functional groups in ascending alphanumeric sequence, with the parts in each group listed in ascending figure and item number sequence. Repair parts kits are listed separately in their own functional group. Items listed are shown on the associated illustrations.
- b. **Special Tools List Work Package.** There are no special tools for the Crew Protection Kit.
- c. **Cross-Reference Indexes Work Package.** There are two cross-reference indexes in this RPSTL: National Stock Number Index and Part Number Index.

**EXPLANATION OF COLUMNS IN THE REPAIR PARTS LISTS**

- a. **Item No. (Column 1).** Indicates the number used to identify items called out in the illustration.
- b. **SMR Code (Column 2).** The SMR code containing supply/requisitioning information, maintenance level authorization criteria, and disposition instruction, as shown in the following breakout:

SOURCE CODE	MAINTENANCE CODE		RECOVERABILITY CODE
XXxxx	xxXXx		xxxxX
1st two positions	3rd position	4th position	5th position
How you get an item.	Who can install, replace or use the item.	Who can do complete repair* on the item.	Who determines disposition action on an unserviceable item.

\* *Complete Repair:* Maintenance capacity, capability, and authority to perform all corrective maintenance tasks of the "Repair" function in a use/user environment in order to restore serviceability to a failed item.

**FIELD MAINTENANCE (UNIT AND DIRECT SUPPORT MAINTENANCE) REPAIR PARTS AND SPECIAL TOOLS LISTS (RPSTL) INTRODUCTION - CONTINUED**

0037 00

**EXPLANATION OF COLUMNS IN THE REPAIR PARTS LISTS - CONTINUED**

- (1) **Source Code.** The source code tells you how to get an item needed for maintenance, repair, or overhaul of an end item/equipment. Explanations of source codes follow:

<u>Code</u>	<u>Application/Explanation</u>
PA PB PC PD PE PF PG	<p>Stocked items; use the applicable NSN to request/requisition items with these source codes. They are authorized to the maintenance category indicated by the code entered in the third position of the SMR code.</p> <p style="text-align: center;"><i>Items coded PC are subject to deterioration.</i></p> <p>.....</p>
KD KF KB	<p>Items with these codes are not to be requested/requisitioned individually. They are part of a kit which is authorized to the maintenance level indicated in the third position of the SMR code. The complete kit must be requisitioned and applied.</p> <p>.....</p>
MO - Made at Unit/ AVUM level MF - Made at DS/AVIM Level MH - Made at GS Level ML - Made at SRA MD - Made at Depot	<p>Items with these codes are not to be requested/requisitioned individually. They must be made from bulk materiel which is identified by the part number in the DESCRIPTION AND USABLE ON CODE (UOC) column and listed in the bulk materiel group work package of the RPSTL. If the item is authorized to you by the third position of the SMR code, but the source code indicates it is made at a higher level, order the item from the higher level of maintenance.</p> <p>.....</p>
AO-Assembled by Unit/ AVUM level AF-Assembled by DS/ AVIM level AH-Assembled by GS level AL-Assembled by SRA AD-Assembled by Depot	<p>Items with these codes are not to be requested/requisitioned individually. The parts that make up the assembled item must be requisitioned or fabricated and assembled at the level of maintenance indicated by the source code. If the third position of the SMR code authorizes you to replace the item, but the source code indicates the item is assembled at a higher level, order the item from the higher level of maintenance.</p>
XA	Do not requisition an "XA" coded item. Order the next higher assembly. (Refer to NOTE below).
XB	If an item is not available from salvage, order it using the CAGEC and P/N.
XC	Installation drawings, diagrams, instruction sheets, field service drawings; identified by manufacturer's P/N.
XD	Item is not stocked. Order an XD-coded item through normal supply channels using the CAGEC and P/N given, if no NSN is available.

**NOTE**

Cannibalization of controlled exchange, when authorized, may be used as a source of supply for items with the above source codes, except for those source coded "XA" or those aircraft support items restricted by requirements of AR 750-1.



**FIELD MAINTENANCE (UNIT AND DIRECT SUPPORT MAINTENANCE) REPAIR PARTS AND SPECIAL TOOLS LISTS (RPSTL) INTRODUCTION - CONTINUED**

**0037 00**

**EXPLANATION OF COLUMNS IN THE REPAIR PARTS LISTS - CONTINUED**

(2) **Maintenance Code.** Maintenance codes tell you the level(s) of maintenance authorized to use and repair support items. The maintenance codes are entered in the third and fourth positions of the SMR code as follows:

(a) Third Position. The maintenance code entered in the third position tells you the lowest maintenance level authorized to remove, replace, and use an item. The maintenance code entered in the third position will indicate authorization to one of the following levels of maintenance:

<u>Code</u>	<u>Application/Explanation</u>
C. . . . .	Crew or Operator maintenance done within Field/AVUM maintenance.
O . . . . .	Unit Level/AVUM maintenance can remove, replace, and use the item.
F. . . . .	Direct Support/AVIM maintenance can remove, replace, and use the item.
H . . . . .	General Support maintenance can remove, replace, and use the item.
L . . . . .	Specialized Repair Activity (SRA) can remove, replace, and use the item.
D . . . . .	Depot Maintenance can remove, replace, and use the item.

(b) Fourth Position. The maintenance code entered in the fourth position tells you whether or not the item is to be repaired and identifies the lowest maintenance level with the capability to do complete repair (perform all authorized repair functions).

**NOTE**

Some limited repair may be done on the item at a lower level of maintenance, if authorized by the Maintenance Allocation Chart (MAC) and SMR codes.

<u>Code</u>	<u>Application/Explanation</u>
O . . . . .	Unit/AVUM is the lowest level that can do complete repair of the item.
F. . . . .	Direct Support/AVIM is the lowest level that can do complete repair of the item.
H . . . . .	General Support is the lowest level that can do complete repair of the item.
L. . . . .	Specialized Repair Activity (SRA) is the lowest level that can do complete repair of the item.
D . . . . .	Depot is the lowest level that can do complete repair of the item.
Z. . . . .	Nonreparable. No repair is authorized.
B. . . . .	No repair is authorized. No parts or special tools are authorized for the maintenance of a "B"-coded item. However, the item may be reconditioned by adjusting, lubricating, etc., at the user level.

**FIELD MAINTENANCE (UNIT AND DIRECT SUPPORT MAINTENANCE) REPAIR PARTS AND SPECIAL TOOLS LISTS (RPSTL) INTRODUCTION - CONTINUED**

**0037 00**

**EXPLANATION OF COLUMNS IN THE REPAIR PARTS LISTS - CONTINUED**

- (3) **Recoverability Code.** Recoverability codes are assigned to items to indicate the disposition action on unserviceable items. The recoverability code is entered in the fifth position of the SMR code as follows:

<u>Code</u>	<u>Application/Explanation</u>
Z. . . . .	Nonreparable item. When unserviceable, condemn and dispose of the item at the level of maintenance shown in the third position of the SMR code.
O . . . . .	Reparable item. When uneconomically repairable, condemn and dispose of the item at the Unit level maintenance.
F. . . . .	Reparable item. When uneconomically repairable, condemn and dispose of the item at Direct Support level.
H . . . . .	Reparable item. When uneconomically repairable, condemn and dispose of the item at General Support level.
D . . . . .	Reparable item. When beyond lower level repair capability, return to depot. Condemnation and disposal of item are not authorized below depot level.
L. . . . .	Reparable item. Condemnation and disposal of item not authorized below Specialized Repair Activity (SRA).
A . . . . .	Item requires special handling or condemnation procedures because of specific reasons (e.g., precious metal content, high dollar value, critical material, or hazardous material). Refer to appropriate manuals/directives for specific instructions.

- c. **NSN - (Column 3).** The NSN for the item is listed in this column.
- d. **CAGEC (Column 4).** The Commercial and Government Entity Code (CAGEC) is a five-digit code which is used to identify the manufacturer, distributor, or Government agency/activity that supplies the item.
- e. **PART NUMBER (Column 5).** Indicates the primary number used by the manufacturer (individual, company, firm, corporation, or Government activity), which controls the design and characteristics of the item by means of its engineering drawings, specifications, standards, and inspection requirements to identify an item or range of items.

**NOTE**

When you use an NSN to requisition an item, the item you receive may have a different part number from the part ordered.

- f. **DESCRIPTION AND USABLE ON CODE (UOC) (Column 6).** This column includes the following information:
  - (1) The Federal item name and, when required, a minimum description to identify the item.
  - (2) P/Ns of bulk materials are referenced in this column in the line entry to be manufactured or fabricated.
  - (3) Hardness Critical Item (HCI). A support item that provides the equipment with special protection from electromagnetic pulse (EMP) damage during a nuclear attack.
  - (4) The statement END OF FIGURE appears just below the last item description in column (6) for a given figure in both the repair parts list and special tools list work packages.

**FIELD MAINTENANCE (UNIT AND DIRECT SUPPORT MAINTENANCE) REPAIR PARTS AND SPECIAL TOOLS LISTS (RPSTL) INTRODUCTION - CONTINUED**

**0037 00**

**EXPLANATION OF COLUMNS IN THE REPAIR PARTS LISTS - CONTINUED**

- g. **QTY (Column 7).** The QTY (quantity per figure) column indicates the quantity of the item used in the breakout shown on the illustration/figure, which is prepared for a functional group, subfunctional group, group or an assembly. A “V” appearing in this column in lieu of a quantity indicates that the quantity is variable and the quantity may vary from application to application.

**EXPLANATION OF CROSS-REFERENCE INDEXES WORK PACKAGE FORMAT AND COLUMNS**

- a. **National Stock Number (NSN) Index Work Package.**
  - (1) **STOCK NUMBER Column.** This column lists the NSN by National Item Identification Number (NIIN) sequence. The NIIN consists of the last nine digits of the NSN (i.e., NSN 5305-01-674-1467). When using this column to locate an item, ignore the first four digits of the NSN. However, the complete NSN should be used when ordering items by stock number.
  - (2) **FIG. Column.** This column lists the number of the figure where the item is identified/located. The figures are in numerical order in WP 0038 00.
  - (3) **ITEM Column.** The item number identifies the item associated with the figure listed in the adjacent FIG. column. This item is also identified by the NSN listed on the same line.
- b. **Part Number (P/N) Index Work Package.** Part numbers in this index are listed in ascending alphanumeric sequence (i.e., vertical arrangement of letter and number combination which places the first letter or digit of each group in order A through Z, followed by the numbers 0 through 9 and each following letter or digit in like order).
  - (1) **PART NUMBER Column.** Indicates the P/N assigned to the item.
  - (2) **FIG. Column.** This column lists the number of the figure where the item is identified/located in the repair parts list and special tools list work packages.
  - (3) **ITEM Column.** The item number is the number assigned to the item as it appears in the figure referenced in the adjacent figure number column.

**SPECIAL INFORMATION**

- a. **Usable On Code (UOC).** The UOC appears in the lower left corner of the DESCRIPTION column heading. Usable on codes are shown as “UOC:” in the Description Column (justified left) on the first line under the applicable item/nomenclature. Uncoded items are applicable to all models. Identification of the UOC’s used in the RPSTL are:

<u>Code</u>	<u>Used On</u>
5K3	M915A3P1 Truck, Tractor Line-Haul
5K3	M915A2P1 Truck, Tractor Line-Haul
5K3	M916A3P1 Truck, Tractor Light Equipment Transporter (LET)
5K3	M917A2P1 Truck, Dump, Heavy Chassis
5K3	M915A4P1 Truck, Tractor Line-Haul
5K3	M917A1P1 Truck, Dump, Heavy Chassis
5K3	M916A1P1 Truck, Tractor Light Equipment Transporter (LET)
5K3	M916A2P1 Truck, Tractor Light Equipment Transporter (LET)

**FIELD MAINTENANCE (UNIT AND DIRECT SUPPORT MAINTENANCE) REPAIR PARTS AND SPECIAL TOOLS LISTS (RPSTL)**

**0037 00**

***SPECIAL INFORMATION - CONTINUED***

**Associated Publications.** The publication(s) listed below pertain to the M915A3P1 Truck, Tractor Line-Haul, M915A2P1 Truck, Tractor Line-Haul, M916A3P1 Truck, Tractor Light Equipment Transporter (LET), M917A2P1 Truck, Dump, Heavy Chassis, M915A4P1 Truck, Tractor Line-Haul, M917A1P1 Truck, Dump, Heavy Chassis, M916A1P1 Truck, Tractor Light Equipment Transporter (LET), and M916A2P1 Truck, Tractor Light Equipment Transporter (LET) and its components:

<b>Publication</b>	<b>Short Title</b>
TM 9-2320-363 Series . . . . .	Series of Manuals for the M915A2P1 Truck, Tractor Line-Haul, M915A4P1 Truck, Tractor Line-Haul, M917A1P1 Truck, Dump, Heavy Chassis, M916A1P1 Truck, Tractor Light Equipment Transporter (LET), and M916A2P1 Truck, Tractor Light Equipment Transporter (LET)
TM 9-2320-302 Series . . . . .	Series of Manuals for the M915A3P1 Truck, Tractor Line-Haul, M916A3P1 Truck, Tractor Light Equipment Transporter (LET), M917A2P1 Truck, Dump, Heavy Chassis
TM 9-2320-303 Series . . . . .	Series of Manuals for the M915A4P1 Truck, Tractor Line-Haul

***HOW TO LOCATE REPAIR PARTS***

- a. **When National Stock Number is Known.**
  - (1) **First.** If you have the NSN, look in the STOCK NUMBER column of the NSN index work package. The NSN is arranged in NIIN sequence. Note the figure and item number next to the NSN.
  - (2) **Second.** Turn to the figure and locate the item number. Verify that the item is the one you are looking for.
- b. **When Part Number is Known.**
  - (1) **First.** If you have the P/N and not the NSN, look in the PART NUMBER column of the P/N index work package. Identify the figure and item number.
  - (2) **Second.** Look up the item on the figure in the applicable repair parts list work package.

***ABBREVIATIONS***

For standard abbreviations see ASME Y14.38-1999, *Abbreviations and Acronyms*.

<b><u>Abbreviations</u></b>	<b><u>Explanation</u></b>
NIIN . . . . .	National Item Identification Number (consists of the last 9 digits of the NSN)
RPSTL . . . . .	Repair Parts and Special Tools Lists
SMR . . . . .	Source, Maintenance, and Recoverability Code
TMDE . . . . .	Test, Measurement, and Diagnostic Equipment

**END OF WORK PACKAGE**



1	2
2-9	3-6

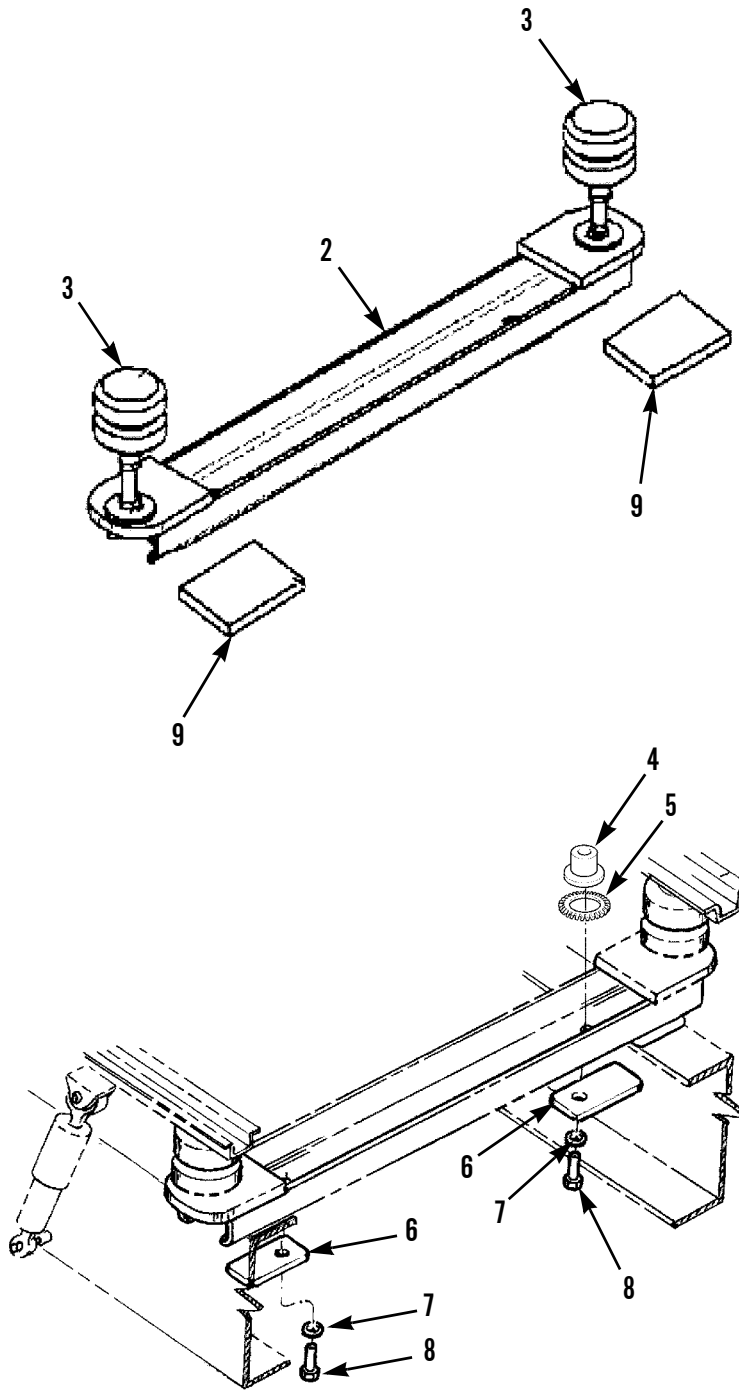


Figure 1. Cab Support Reinforcement Kit

(1) ITEM NO	(2) SMR CODE	(3) NSN	(4) CAGEC	(5) PART NUMBER	(6) DESCRIPTION AND USABLE ON CODES(UOC)	(7) QTY
GROUP 33 SPECIAL PURPOSE KITS						
GROUP 3307 SPECIAL PURPOSE KITS						
FIG. 1 CAB SUPPORT REINFORCEMENT KIT						
1	PAOZZ	2540015338806	19207	KIT #1	ARMOR SET,SUPPLEMEN CAB SUPPORT REINFORCEMENT.....	1
2	PFOZZ	2590015339651	54786	0257970010-00	.BRACKET,VEHICULAR C.....	1
3	PFOZZ	5340015338151	54786	534000179-00	..BUMPER,NONMETALLIC.....	2
4	PAOZZ	5310014906056	3A054	91030A036	..NUT,PLAIN,EXTENDED 0.750 PART OF KIT P/N 113599-1.....	2
5	PAOZZ	5310015338861	54786	5320000105-00	..WASHER,LOCK BLANK 0.750" PART OF KIT P/N 113599-1.....	2
6	PFOZZ	5340015338141	54786	025100978-00	..PLATE,MOUNTING.....	2
7	PAOZZ	5310012756826	65525	16/206-12	.WASHER,FLAT 0.75 PART OF KIT P/N 113599-1.....	2
8	PAOZZ	5305009381539	80204	B1821BH075C200N	.SCREW,CAP,HEXAGON H 0.750 X 2 PART OF KIT P/N 113599-1.....	2
9	PFOZZ	5365015338052	54786	0257970624-00	.SPACER,PLATE.....	2

END OF FIGURE

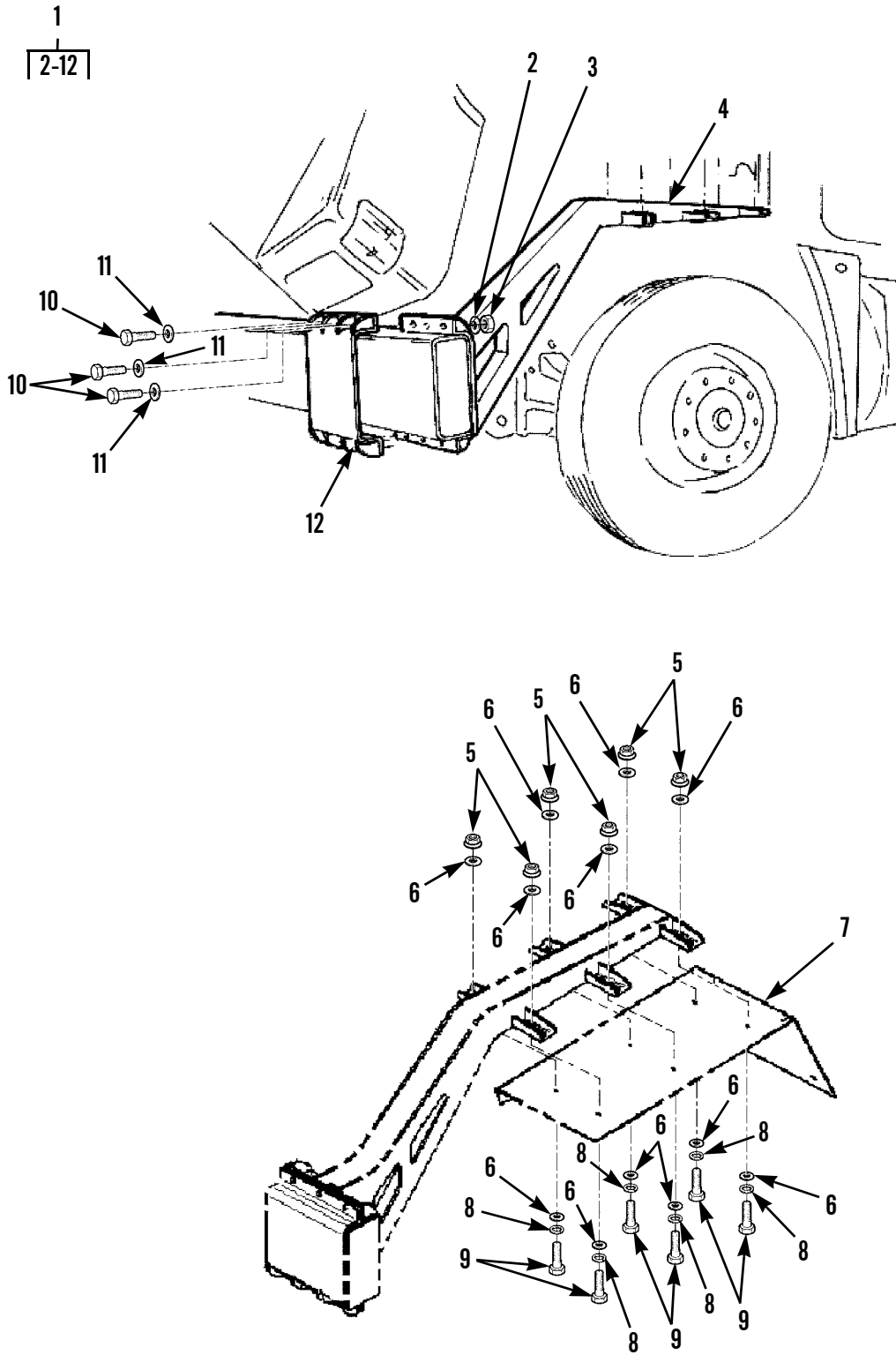


Figure 2. Wheel Housing Armor Kit



(1) ITEM NO	(2) SMR CODE	(3) NSN	(4) CAGEC	(5) PART NUMBER	(6) DESCRIPTION AND USABLE ON CODES(UOC)	(7) QTY
GROUP 3307 SPECIAL PURPOSE KITS						
FIG. 2 WHEEL HOUSING ARMOR KIT						
1	PAOZZ	2540015338810	54786	113582-1-103	ARMOR SET,SUPPLEMEN.....	1
2	PAOZZ		96906	MS27183-21	.WASHER,FLAT 0.625 PART OF KIT P/N 113599-1.....	12
3	PAOZZ	5310015339625	39428	91030A035	.NUT,PLAIN,EXTENDED 0.625 PART OF KIT P/N 113599-1.....	12
4	PFOZZ	2590015339649	54786	0257970970-00	.BRACKET,VEHICULAR C ARMOR WHEEL RH	2
4	PFOZZ	2540015337483	54786	0257970971-00	.ARMOR,SUPPLEMENTAL, LH.....	1
5	PAOZZ	5310015339640	39428	91030A033	.NUT,PLAIN,EXTENDED 0.500 PART OF KIT P/N 113599-1.....	12
6	PAOZZ	5310007630254	43999	2W2SP16-32-125	.WASHER,FLAT 0.50 PART OF KIT P/N 113599-1.....	24
7	PFOZZ	2540015337480	54786	0257970006-00	.ARMOR,SUPPLEMENTAL, WHEEL DEFLECTOR,RH.....	1
7	PFOZZ	2540015337479	54786	0257970007-00	.ARMOR,SUPPLEMENTAL, WHEEL DEFLECTOR, LH.....	1
8	PAOZZ	5310015338858	86727	OEM 7238	.WASHER,LOCK BLANK PART OF KIT P/N 113599-1.....	12
9	PFOZZ	5305000712070	80204	B1821BH050C175N	.SCREW,CAP,HEXAGON H 0.500 X 1.750 PART OF KIT P/N 113599-1.....	12
10	PAOZZ	5305007247224	80204	B1821BH063C250N	.SCREW,CAP,HEXAGON H 0.625 X 2.50 PART OF KIT P/N 113599-1.....	12
11	PAOZZ	5310015338863	54786	5320000103-00	.WASHER,LOCK BLANK 0.625" PART OF KIT P/N 113599-1.....	12
12	PFOZZ	2590015339648	54786	0257970967-00	.BRACKET,VEHICULAR C ARMOR WHEEL...	2

END OF FIGURE

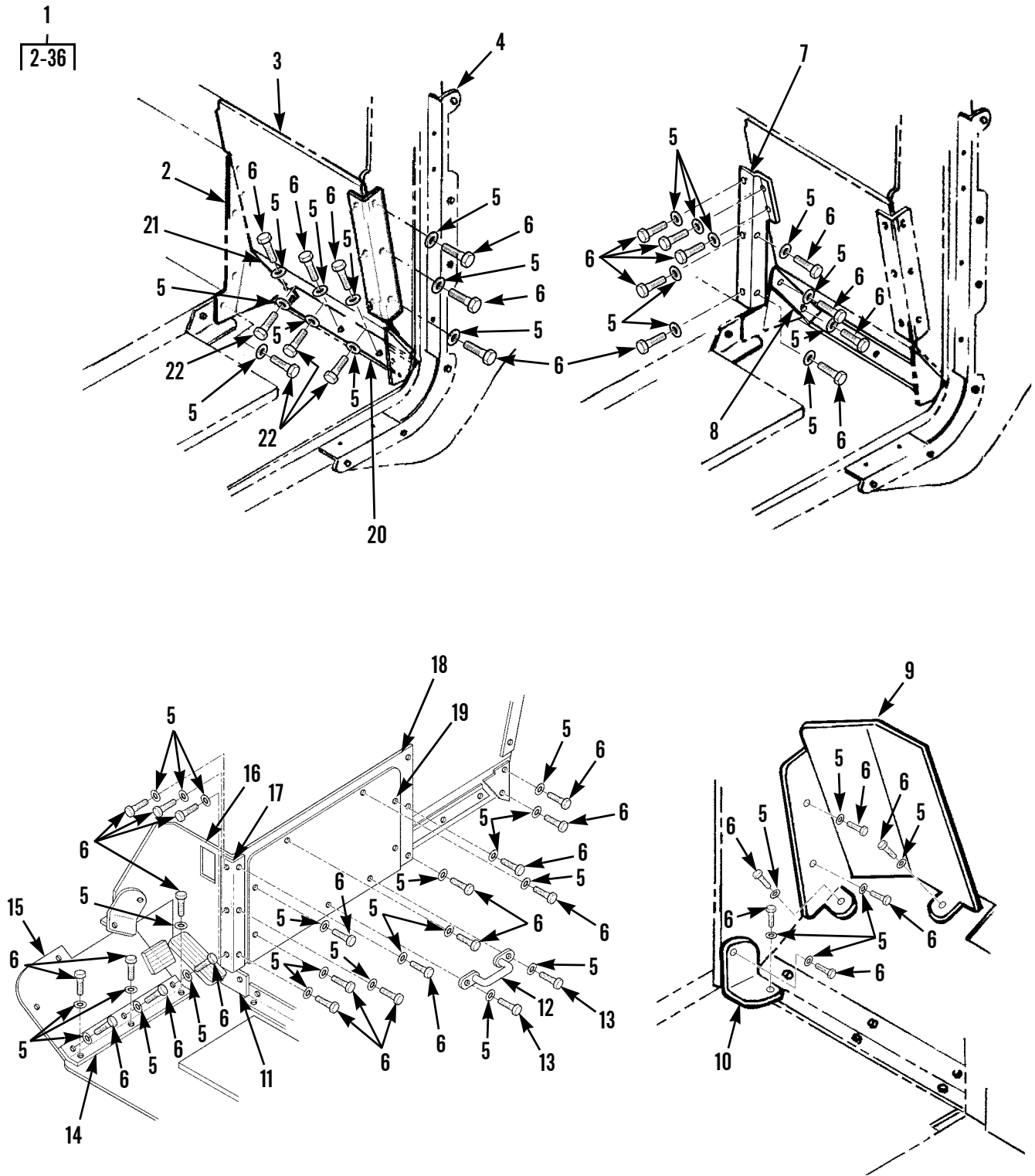


Figure 3. Interior Protection Armor Kit (Sheet 1 of 3)

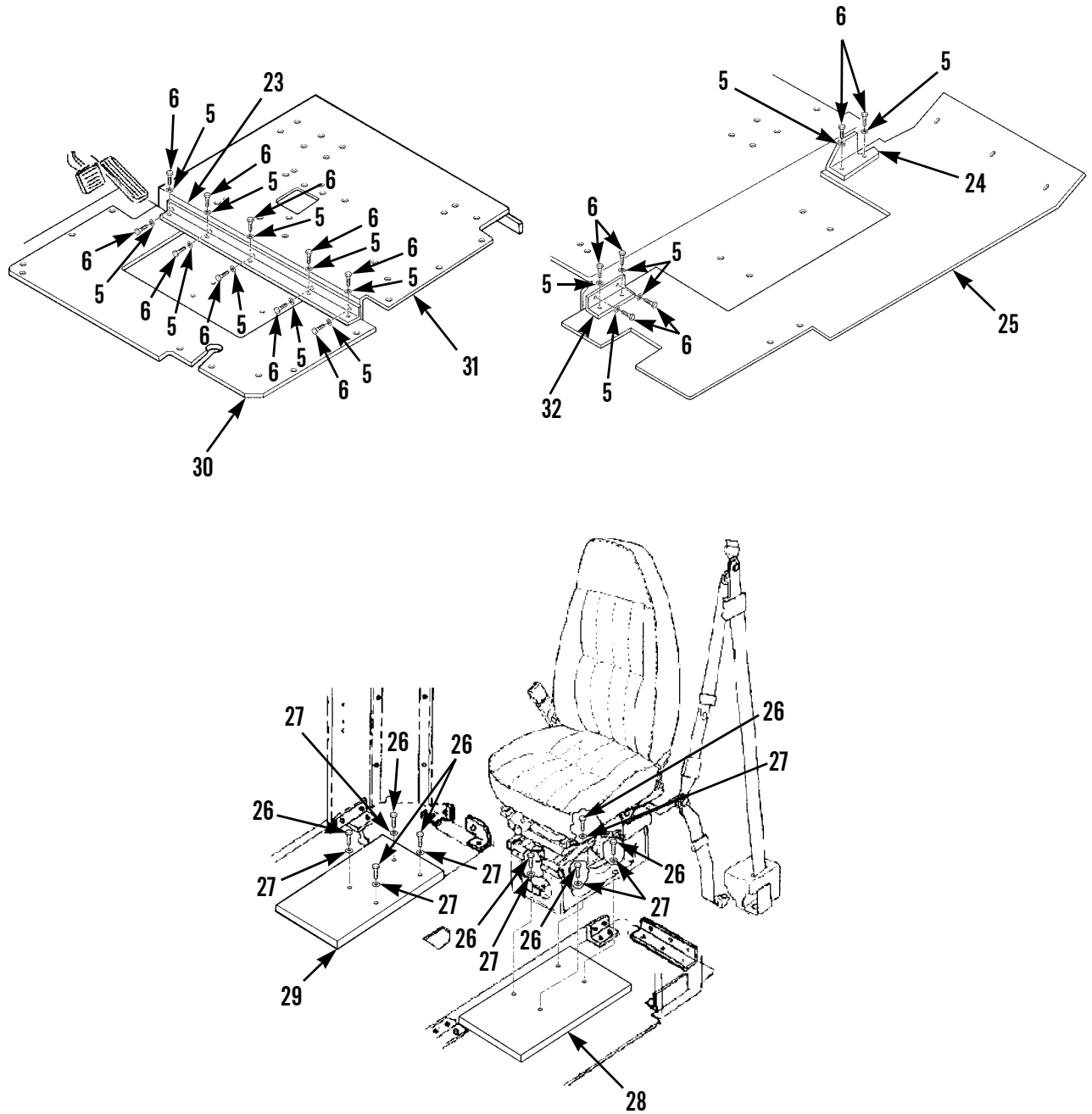


Figure 3. Interior Protection Armor Kit (Sheet 2 of 3)

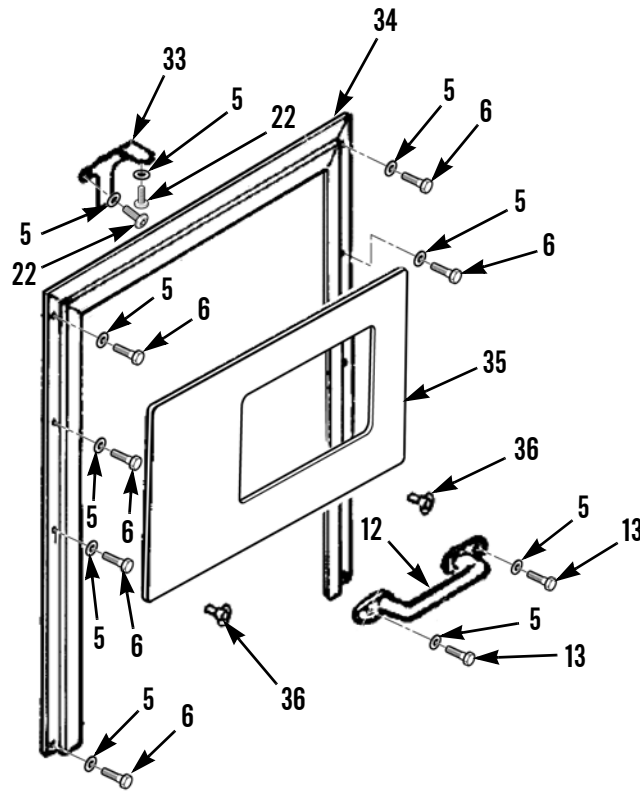


Figure 3. Interior Protection Armor Kit (Sheet 3 of 3)

(1) ITEM NO	(2) SMR CODE	(3) NSN	(4) CAGEC	(5) PART NUMBER	(6) DESCRIPTION AND USABLE ON CODES(UOC)	(7) QTY
GROUP 3307 SPECIAL PURPOSE KITS						
FIG. 3 INTERIOR PROTECTION ARMOR KIT						
1	PAOZZ	2540015338813	54786	113584-1-103	ARMOR SET,SUPPLEMEN.....	1
2	PFOZZ	2540015337530	54786	0257027793-00	.ARMOR,SUPPLEMENTAL, INTERIOR, RIGHT OF CENTER.....	1
3	PFOZZ	2540015337529	54786	0257020811-00	.ARMOR,SUPPLEMENTAL, RH INTERIOR...	1
4	PFOZZ	2590015339672	54786	0257020982-00	.BRACKET,VEHICULAR C FIREWALL TO INTERIOR RH.....	1
5	PAOZZ	5310004923208	61510	4R1604	.WASHER,FLAT 0.312 X 0.900 X 0.125 PART OF KIT P/N 113599-1.....	72
6	PAOZZ	5305011972434	75160	19H3053	.SCREW,CAP,HEXAGON H 0.312 X 1.0 PART OF KIT P/N 113599-1.....	72
7	PFOZZ	2590015339669	54786	0257120976-00	.BRACKET,VEHICULAR C CENTER FIREWALL TO RIGHT FIREWALL.....	1
8	PFOZZ	2590015339676	54786	0257020981-00	.BRACKET,VEHICULAR C MIDDLE FLOOR TO BACK WALL.....	1
9	PFOZZ	2590015339634	54786	0257020814-00	.BRACKET,VEHICULAR C.....	1
10	PFOZZ	2590015339642	54786	0257120973-00	.BRACKET,VEHICULAR C FLOOR TO SIDE.	1
11	PFOZZ	2540015337536	54786	0257020972-00	.ARMOR,SUPPLEMENTAL, FLOOR TO FIREWALL.....	1
12	PFOZZ	5340015338143	54786	5340000106-00	.HANDLE,BOW.....	2
13	PAOZZ		39428	91255A540	.SCREW,CAP,HEXAGON H 0.250 X 0.750 PART OF KIT P/N 113599-1.....	2
14	PFOZZ	2540015337646	54786	0257127725-00	.ARMOR,SUPPLEMENTAL,.....	1
15	PFOZZ	2540015337644	54786	0257122227-00	.ARMOR,SUPPLEMENTAL, FLOOR LH.....	1
16	PFOZZ	2540015337610	54786	0257020813-00	.ARMOR,SUPPLEMENTAL, INTERIOR, DRIVER SIDE.....	1
17	PFOZZ	2590015339628	54786	0257020988-00	.BRACKET,VEHICULAR C INTERNAL FIREWALL DRIVER.....	1
18	PFOZZ	2540015338038	54786	0257022265-00	.ARMOR,SUPPLEMENTAL, INTERIOR CENTER,0257027365-00 ALTERNATE PART NUMBER.....	1
19	PFOZZ	2540015337534	54786	0257022266-00	.ARMOR,SUPPLEMENTAL, INTERIOR FIREWALL, 0257027366-00 ALTERNATE PART NUMBER.....	1
20	PFOZZ	2540015337528	54786	0257120985-00	.ARMOR,SUPPLEMENTAL, FLOOR TO FIREWALL, RH.....	1
21	PFOZZ	2540015337525	54786	0257022268-00	.ARMOR,SUPPLEMENTAL, INTERNAL RH, 0257027368-00 ALTERNATE PART NUMBER.	1
22	PAOZZ	5305015141091	96906	MS51491-013	.SCREW,CAP,HEXAGON H PART OF KIT P/N 113599-1.....	4
23	PFOZZ	2540015337624	54786	0257120974-00	.ARMOR,SUPPLEMENTAL, DRIVER FLOOR TO MIDDLE FLOOR.....	1
24	PFOZZ	2540015337620	54786	0257120975-00	.ARMOR,SUPPLEMENTAL, FRONT TO MIDDLE FLOOR.....	1
25	PFOZZ	2540015337640	54786	0257120849-00	.ARMOR,SUPPLEMENTAL, PASSENGER SIDE	1
26	PAOZZ	5305008213869	80204	B1821BH038C175N	.SCREW,CAP,HEXAGON H 0.375 X 1.750 PART OF KIT P/N 113599-1.....	8
27	PAOZZ	5310015226093	04664	82-1013-0038	.WASHER,FLAT 0.375 X 0.900 X 0.125 PART OF KIT P/N 113599-1.....	8

(1) ITEM NO	(2) SMR CODE	(3) NSN	(4) CAGEC	(5) PART NUMBER	(6) DESCRIPTION AND USABLE ON CODES(UOC)	(7) QTY
28	PFOZZ	2540015337642	54786	0257120805-00	.ARMOR,SUPPLEMENTAL, FLOOR, PASSENGER SIDE.....	1
29	PFOZZ	2540015337641	54786	0257120816-00	.ARMOR,SUPPLEMENTAL, FLOOR,DRIVER..	1
30	PFOZZ	2540015337623	54786	0257120850-00	.ARMOR,SUPPLEMENTAL, LH.....	1
31	PFOZZ	2540015337628	54786	0257120815-00	.ARMOR,SUPPLEMENTAL, MIDDLE.....	1
32	PFOZZ	2590015339673	54786	0257120986-00	.BRACKET,VEHICULAR C MIDDLE FLOOR TO RH FLOOR.....	1
33	PFOZZ	2590015339645	54786	0257017703-00	.BRACKET,VEHICULAR C.....	1
34	PFOZZ	2510015339721	54786	0257060968-00	.FRAME SECTION,WINDO.....	1
35	PFOZZ	2540015337632	54786	0257060065-00	.ARMOR,SUPPLEMENTAL,.....	1
36	XDOZZ		54786	0257120993-00	.SPACER,STEPPED.....	1

END OF FIGURE

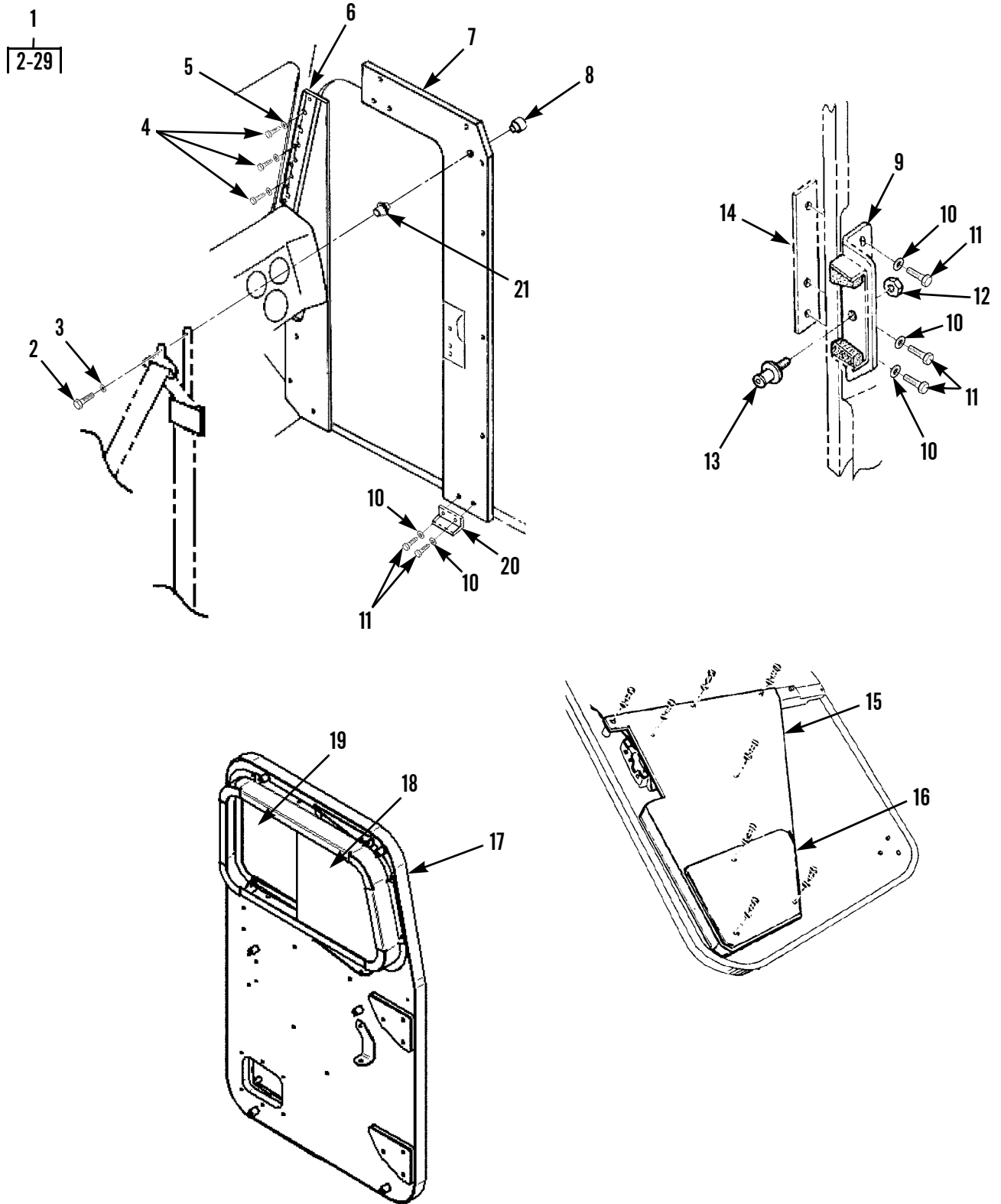


Figure 4. Side Protection Armor Kit (Sheet 1 of 2)

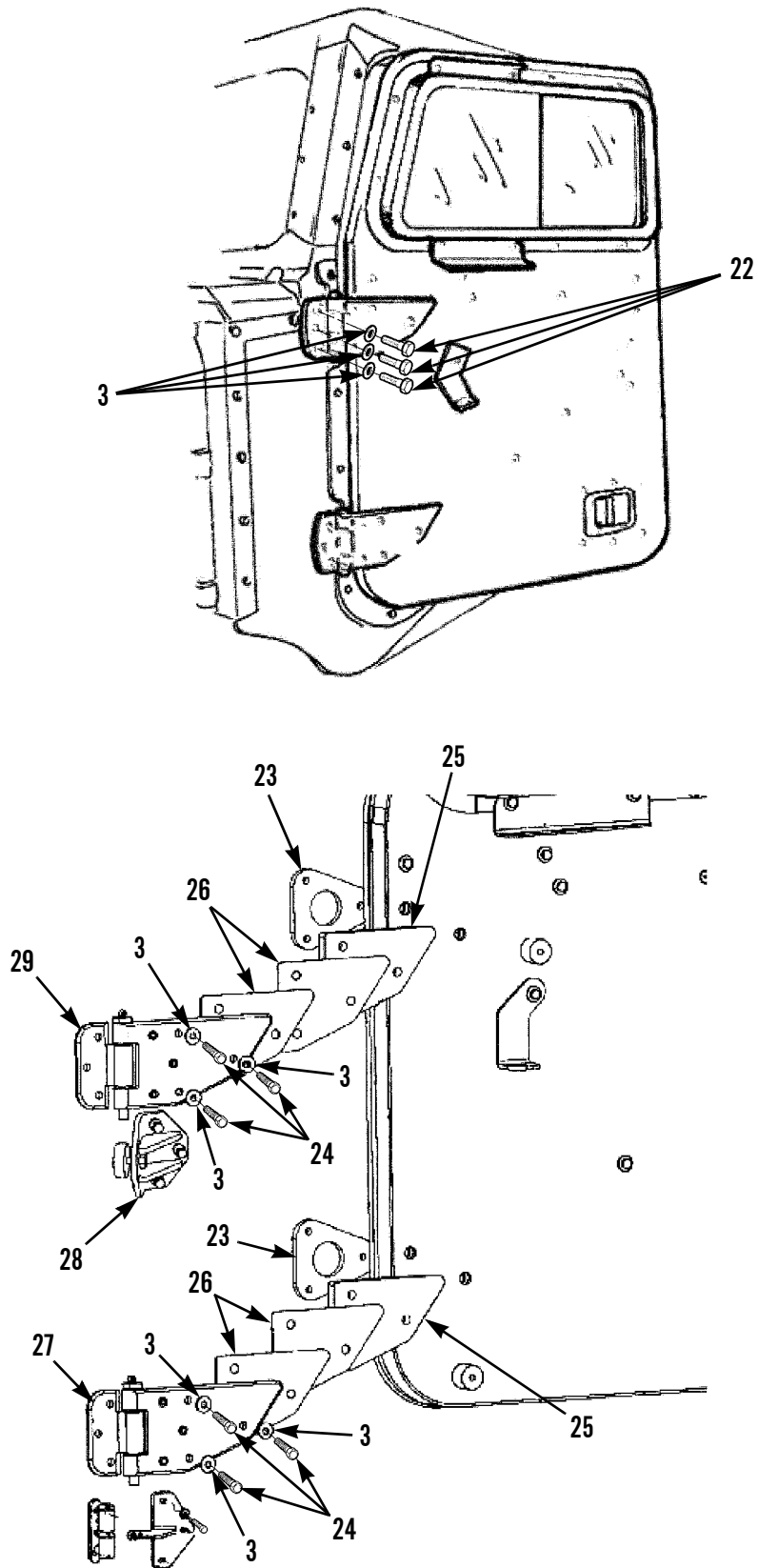


Figure 4. Side Protection Armor Kit (Sheet 2 of 2)



(1) ITEM NO	(2) SMR CODE	(3) NSN	(4) CAGEC	(5) PART NUMBER	(6) DESCRIPTION AND USABLE ON CODES(UOC)	(7) QTY
GROUP 3307 SPECIAL PURPOSE KITS						
FIG. 4 SIDE PROTECTION ARMOR KIT						
1	PAOZZ	2540015338814	54786	113586-1-103	ARMOR SET,SUPPLEMEN.....	1
1	PAOZZ	2540015338816	54786	113588-1-103	ARMOR SET,SUPPLEMEN.....	1
2	PAOZZ	5305000712061	80204	B1821BH044C300N	.SCREW,CAP,HEXAGON H 0.437 X 3.00	2
					PART OF KIT P/N 113599-1.....	
3	PAOZZ	5310008090940	02978	15X3XX1353	.WASHER,FLAT 0.437 X 0.938 X 0.125	7
					PART OF KIT P/N 113599-1.....	
4	PAOZZ	5305000680509	80204	B1821BH025C125N	.SCREW,CAP,HEXAGON H 0.250 X 1.250	3
					PART OF KIT P/N 113599-1.....	
5	PAOZZ		82386	400-20MZ	.WASHER,FLAT 0.250" X 0.615 X 0.61	3
					PART OF KIT P/N 113599-1.....	
6	PFOZZ	2540015337520	54786	0257032251-00	.ARMOR,SUPPLEMENTAL, A-PILLAR,RH...	1
6	PFOZZ	2540015337743	54786	0257032250-00	.ARMOR,SUPPLEMENTAL, A-PILLAR,LH...	1
7	PFOZZ	2540015337631	54786	0257032213-00	.ARMOR,SUPPLEMENTAL, PANEL,RH.....	1
7	PFOZZ	2540015337513	54786	0257032214-00	.ARMOR,SUPPLEMENTAL, PANEL,LH.....	1
8	PFOZZ	5365015337737	54786	0257030992-00	.SPACER,STEPPED.....	1
9	PFOZZ	2590015339654	54786	0257030962-00	.BRACKET,VEHICULAR C LOCK,RH.....	1
9	PFOZZ	2590015339632	54786	0257030963-00	.BRACKET,VEHICULAR C LOCK,LH.....	1
10	PAOZZ	5310004923208	61510	4R1604	.WASHER,FLAT 0.312 X 0.900 X 0.125	10
					PART OF KIT P/N 113599-1.....	
11	PAOZZ	5305002264831	80204	B1821BH031C150N	.SCREW,CAP,HEXAGON H 0.312 X 1.50	5
					PART OF KIT P/N 113599-1.....	
12	PAOZZ	5310015339629	39428	91030A435	.NUT,PLAIN,EXTENDED 0.437-20 PART	2
					OF KIT P/N 113599-1.....	
13	PFOZZ	2540015339733	54786	0257010012-00	.WEDGE,DOOR DOVETAIL.....	1
14	PFOZZ	5340015339764	54786	0257030964-00	.PLATE,MOUNTING.....	1
15	PFOZZ		54786	0257040912-00	.DOOR PANEL INNER,RH.....	1
15	PFOZZ		54786	0257040913-00	.DOOR PANEL INNER,LH.....	1
16	PFOZZ		54786	0257047760-00	.DOOR PANEL INNER,RH.....	1
16	PFOZZ		54786	0257047785-00	.DOOR PANEL INNER,LH.....	1
17	PFOZZ	2510015339728	54786	0257040001-00	.DOOR,VEHICULAR RH.....	1
17	PFOZZ	2540015337510	54786	0257040002-00	.ARMOR,SUPPLEMENTAL, LH.....	1
18	PAOZZ	2540015341086	54786	0257044402-00	.WINDOW,VEHICULAR REAR,DOOR,LH....	1
18	PAOZZ	2540015341097	54786	0257044401-00	.WINDOW,VEHICULAR REAR,DOOR,RH....	1
19	PAOZZ	2540015341093	54786	0257044404-00	.WINDOW,VEHICULAR FRONT,DOOR LH....	1
19	PAOZZ	2540015341099	54786	0257044403-00	.WINDOW,VEHICULAR FRONT,DOOR RH....	1
20	PFOZZ	2540015337637	54786	0257030952-00	.ARMOR,SUPPLEMENTAL, SIDE PANEL RH.	1
20	PFOZZ	2590015339657	54786	0257030953-00	.BRACKET,VEHICULAR C SIDE PANEL LH.	1
21	PFOZZ	5365015337735	54786	0257030991-00	.SPACER,STEPPED.....	1
22	PAOZZ	5305000711786	80204	B1821BH044C100N	.SCREW,CAP,HEXAGON H 0.437 X 1.00	6
					PART OF KIT P/N 113599-1.....	
23	PFOZZ	5365015338043	54786	0257040914-00	.SPACER,PLATE.....	2
24	PAOZZ	5305000712060	80204	B1821BH044C275N	.SCREW,CAP,HEXAGON H PART OF KIT P/N	6
					113599-1.....	
25	PFOZZ	5365015338044	54786	0257040915-00	.SPACER,PLATE.....	2
26	PFOZZ	2540015337518	54786	0257040916-00	.ARMOR,SUPPLEMENTAL,.....	4
27	PFOZZ	2510015337515	54786	0257040925-00	.ARMOR,SUPPLEMENTAL, LOWER,RH.....	1
27	PFOZZ	2510015337505	54786	0257040924-00	.ARMOR,SUPPLEMENTAL, LOWER,LH.....	1

(1) ITEM NO	(2) SMR CODE	(3) NSN	(4) CAGEC	(5) PART NUMBER	(6) DESCRIPTION AND USABLE ON CODES(UOC)	(7) QTY
28	PFOZZ	5340015338153	54786	0257040009-00	.BUMPER, NONMETALLIC.....	4
29	PFOZZ	2510015337516	54786	0257040923-00	.ARMOR, SUPPLEMENTAL, UPPER, RH.....	1
29	PFOZZ	2510015337507	54786	0257040922-00	.ARMOR, SUPPLEMENTAL, UPPER, LH.....	1

END OF FIGURE



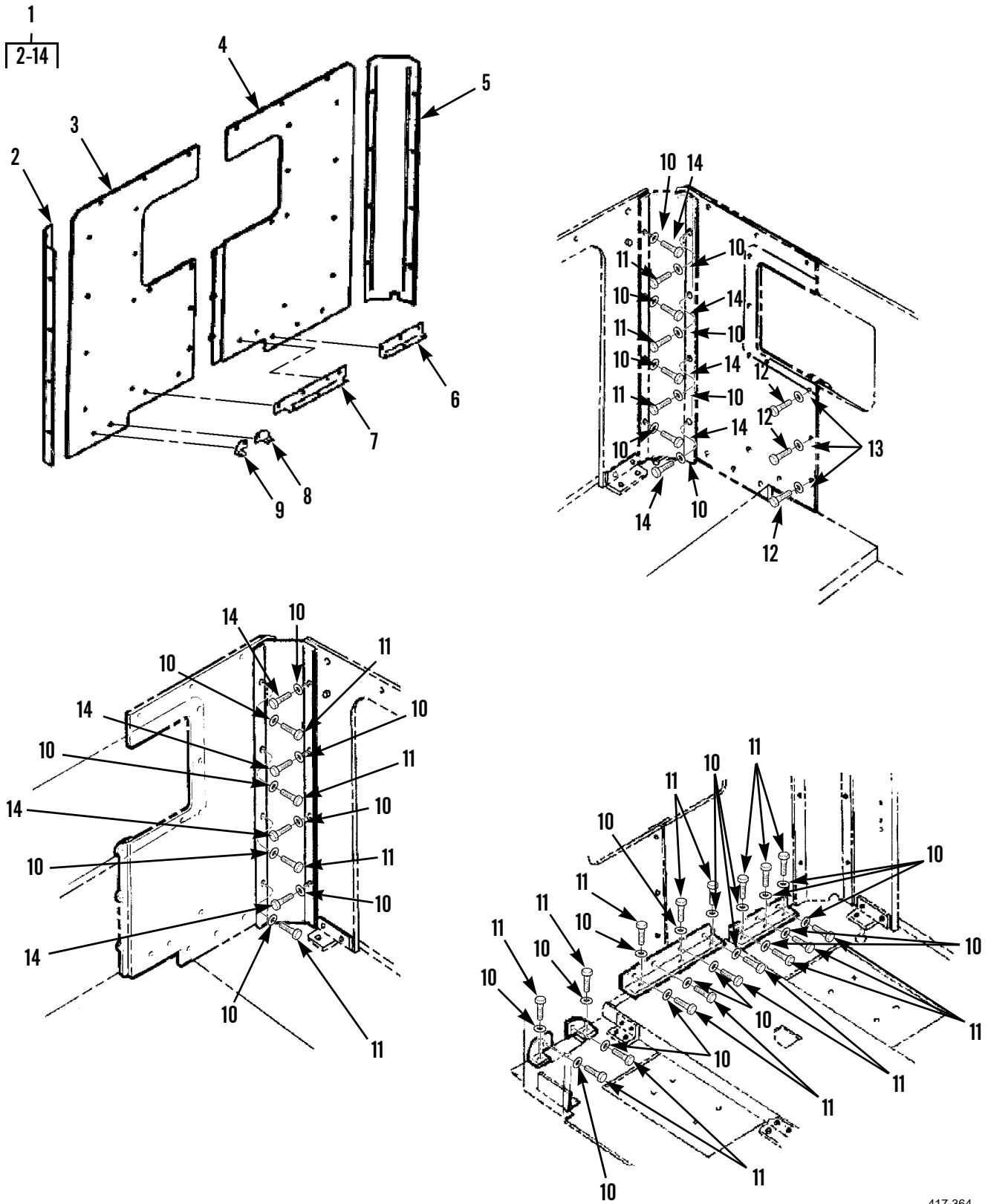


Figure 5. Rear Protection Armor Kit

(1) ITEM NO	(2) SMR CODE	(3) NSN	(4) CAGEC	(5) PART NUMBER	(6) DESCRIPTION AND USABLE ON CODES(UOC)	(7) QTY
GROUP 3307 SPECIAL PURPOSE KITS						
FIG. 5 REAR PROTECTION ARMOR KIT						
1	PAOZZ	2540015338817	54786	113590-1-103	ARMOR SET,SUPPLEMEN.....	1
2	PFOZZ	2590015339656	54786	0257030827-00	.BRACKET,VEHICULAR C RH REAR.....	1
3	PFOZZ	2540015337501	54786	0257062205-00	.ARMOR,SUPPLEMENTAL, RH REAR, 0257062305-00 ALTERNATE PART NUMBER.	1
4	PFOZZ	2540015337497	54786	0257060844-00	.ARMOR,SUPPLEMENTAL, LH REAR.....	1
5	PFOZZ	2540015337481	54786	0257030826-00	.ARMOR,SUPPLEMENTAL, LH REAR.....	1
6	PFOZZ	2590015339659	54786	0257120984-00	.BRACKET,VEHICULAR C.....	1
7	PFOZZ	2590015339660	54786	0257060980-00	.BRACKET,VEHICULAR C MIDDLE FLOOR TO BACK WALL.....	1
8	PFOZZ	2590015339665	54786	0257120987-00	.BRACKET,VEHICULAR C MIDDLE FLOOR TO BACK WALL.....	1
9	PFOZZ	2590015339667	54786	0257120983-00	.BRACKET,VEHICULAR C RH FLOOR TO BACK.....	1
10	PAOZZ	5310004923208	61510	4R1604	.WASHER,FLAT PART OF KIT P/N 113599- 1.....	33
11	PAOZZ	5305011972434	75160	19H3053	.SCREW,CAP,HEXAGON H 0.312 X 1.0 PART OF KIT P/N 113599-1.....	25
12	PAOZZ	5305004559960	80205	MS24693-C120	.SCREW,MACHINE COUNTERSUNK, 0.312 X 1.00 PART OF KIT P/N 113599-1.....	3
13	PAOZZ	5310015338801	39428	95221A111	.WASHER,FLAT 0.312 (M8) PART OF KIT P/N 113599-1.....	4
14	PAOZZ	5305002264831	80204	B1821BH031C150N	.SCREW,CAP,HEXAGON H 0.312 X 1.50 PART OF KIT P/N 113599-1.....	8

END OF FIGURE



1  
2-29

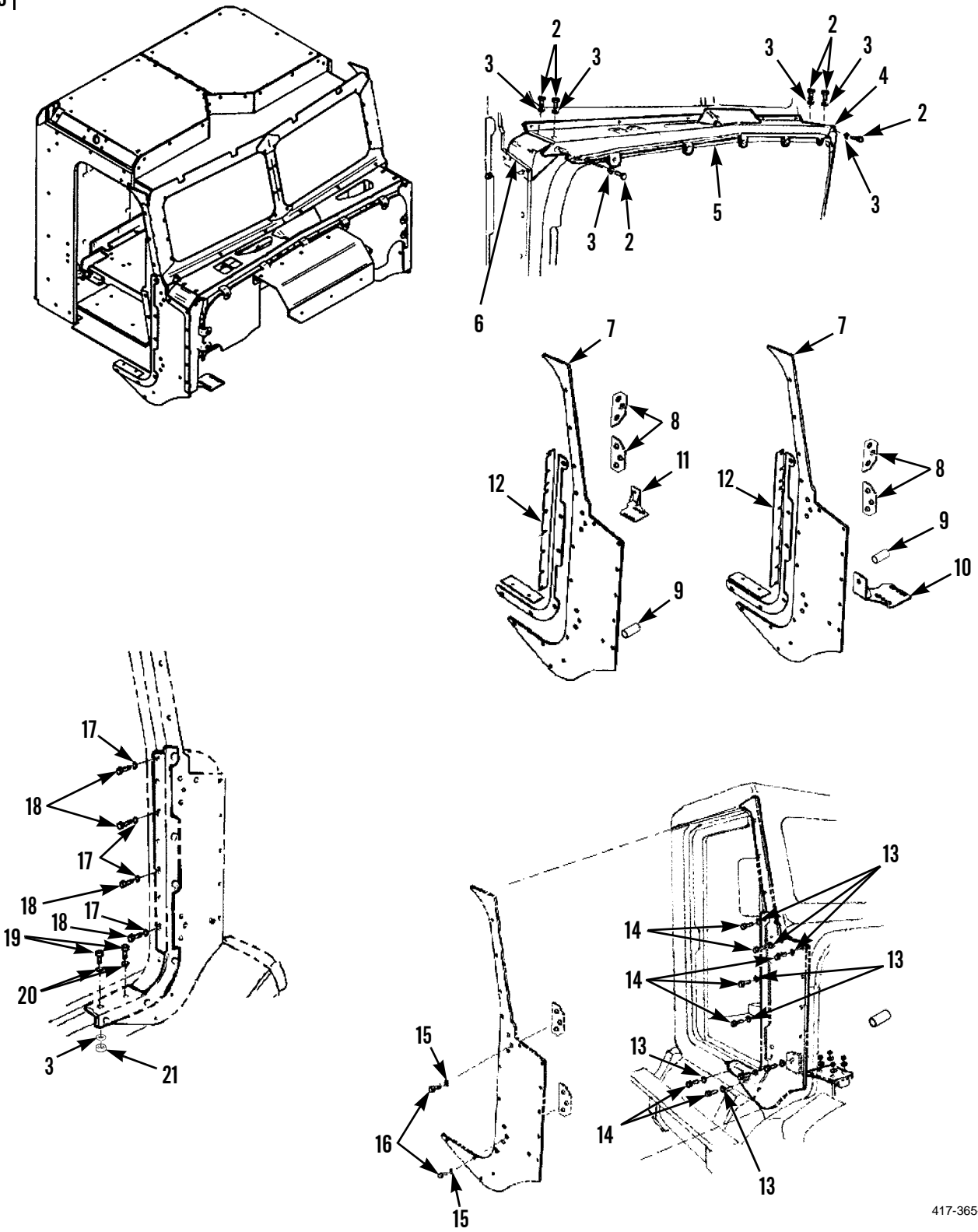


Figure 6. Front Cowl Protection Armor Kit (Sheet 1 of 2)

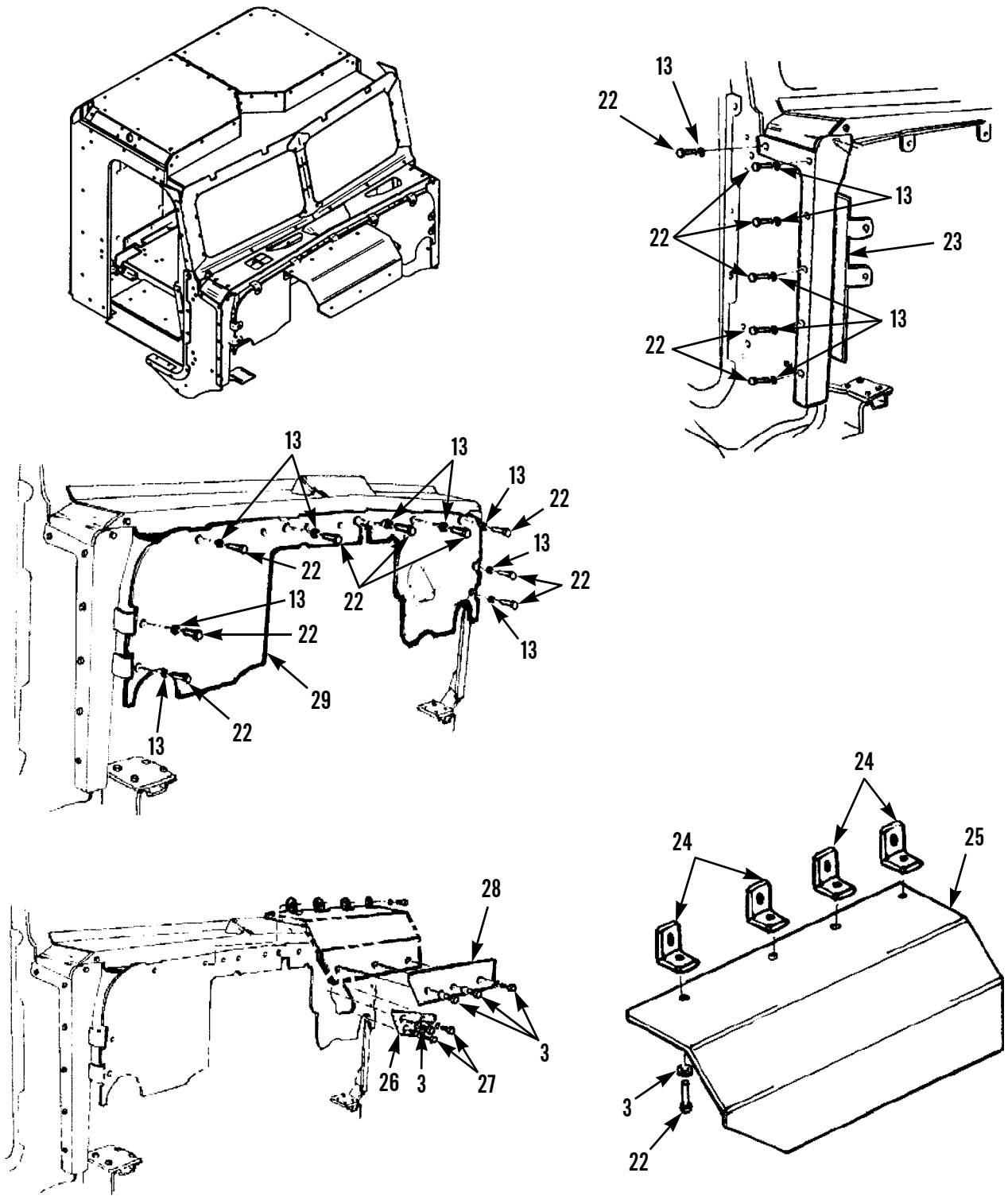


Figure 6. Front Cowl Protection Armor Kit (Sheet 2 of 2)



(1) ITEM NO	(2) SMR CODE	(3) NSN	(4) CAGEC	(5) PART NUMBER	(6) DESCRIPTION AND USABLE ON CODES(UOC)	(7) QTY
GROUP 3307 SPECIAL PUTPOSE KITS						
FIG. 6 FRONT COWL PROTECTION ARMOR KIT						
1	PAOZZ	2540015338820	54786	113592-1-103	ARMOR SET,SUPPLEMEN.....	1
2	PAOZZ	5305011972434	75160	19H3053	.SCREW,CAP,HEXAGON H 0.312 X 1.0	11
3	PAOZZ	5310004923208	61510	4R1604	PART OF KIT P/N 113599-1.....	18
4	PFOZZ	2540015338142	54786	0257020830-00	.WASHER,FLAT 0.312 X 0.900 X 0.125	1
5	PFOZZ	2540015337538	54786	0257020810-00	PART OF KIT P/N 113599-1.....	1
6	PFOZZ	2540015337539	54786	0257020831-00	.ARMOR,SUPPLEMENTAL, EXTERIOR LH...	1
7	PFOZZ	2540015338042	54786	0257032256-00	.ARMOR,SUPPLEMENTAL, EXTERIOR	1
7	PFOZZ	2540015337848	54786	0257032255-00	CENTER.....	1
8	PFOZZ	5365015339708	54786	0257020955-00	.ARMOR,SUPPLEMENTAL, EXTERIOR RH...	1
9	PFOZZ	5365015338037	54786	0257030960-00	.ARMOR,SUPPLEMENTAL, EXTERIOR RH,	1
10	PFOZZ	2590015339677	54786	0257030965-00	0257037356-00 ALTERNATE PART NUMBER.	1
11	PFOZZ	2590015339622	54786	0257030966-00	.ARMOR,SUPPLEMENTAL,.....	1
12	PFOZZ	2540015337524	54786	0257030820-00	.SPACER,PLATE HINGE SIDE.....	2
12	PFOZZ	2540015337616	54786	0257030819-00	.SPACER,STRAIGHT EXTERIOR SIDE.....	2
13	PAOZZ	5310001585175	82386	400-132	.BRACKET,VEHICULAR C ENGINE COVER	1
14	PAOZZ	5305012854924	64678	23-09464-075	LH.....	1
15	PAOZZ	5310008090940	02978	15X3XX1353	.BRACKET,VEHICULAR C ENGINE COVER	1
16	PAOZZ	5305000711786	80204	B1821BH044C100N	RH.....	1
17	PAOZZ	5310008805977	80205	MS15795-811	.ARMOR,SUPPLEMENTAL, EXTERIOR RH	1
18	PAOZZ	5305000680509	80204	B1821BH025C125N	OVERLAP.....	1
19	PAOZZ	5305004559960	80205	MS24693-C120	.ARMOR,SUPPLEMENTAL, EXTERIOR LH	1
20	PAOZZ	5310015338801	39428	95221A111	OVERLAP.....	1
21	PAOZZ	5310015339633	39428	91030A029	.WASHER,FLAT 0.312 X 1.00 X 0.125	45
22	PAOZZ	5305015141091	96906	MS51491-013	PART OF KIT P/N 113599-1.....	23
23	PFOZZ	2540015339730	54786	0257020833-00	.SCREW,CAP,HEXAGON H 0.312 X 0.750	4
23	PFOZZ	2540015337495	54786	0257020832-00	PART OF KIT P/N 113599-1.....	4
					.WASHER,FLAT PART OF KIT P/N 113599-1.....	4
					1.....	4
					.SCREW,CAP,HEXAGON H 0.437 X 1.00	4
					PART OF KIT P/N 113599-1.....	14
					.WASHER,FLAT 0.250 X 0.750 X 0.061	14
					PART OF KIT P/N 113599-1.....	14
					.SCREW,CAP,HEXAGON H 0.250 X 1.250	4
					PART OF KIT P/N 113599-1.....	4
					.SCREW,MACHINE COUNTERSUNK,	4
					0.312 X 1.00 PART OF KIT P/N	4
					113599-1.....	4
					.WASHER,FLAT 0.312 (M8) PART OF KIT	4
					P/N 113599-1.....	4
					.NUT,PLAIN,EXTENDED 0.312 PART OF	4
					KIT P/N 113599-1.....	21
					.SCREW,CAP,HEXAGON H 0.312 X 1.250	1
					PART OF KIT P/N 113599-1.....	1
					.ARMOR,SUPPLEMENTAL, EXTERIOR RH...	1
					.ARMOR,SUPPLEMENTAL, EXTERIOR	1
					ARMOR, LEFT SIDE.....	

(1) ITEM NO	(2) SMR CODE	(3) NSN	(4) CAGEC	(5) PART NUMBER	(6) DESCRIPTION AND USABLE ON CODES(UOC)	(7) QTY
25	PFOZZ	2540015337504	54786	0257027706-00	.ARMOR,SUPPLEMENTAL,.....	1
26	PFOZZ	2540015337493	54786	0257020806-00	.ARMOR,SUPPLEMENTAL, FIRE WALL.....	1
27	PAOZZ	5305002264831	80204	B1821BH031C150N	.SCREW,CAP,HEXAGON H 0.312 X 1.50 PART OF KIT P/N 113599-1.....	3
28	PFOZZ	2540015337503	54786	0257027763-00	.ARMOR,SUPPLEMENTAL, AIR FILTER....	1
29	PFOZZ	2540015337509	54786	0257022262-00	.ARMOR,SUPPLEMENTAL, EXTERIOR, 0257027362-00 ALTERNATE PART NUMBER.	1

END OF FIGURE

1  
2-24

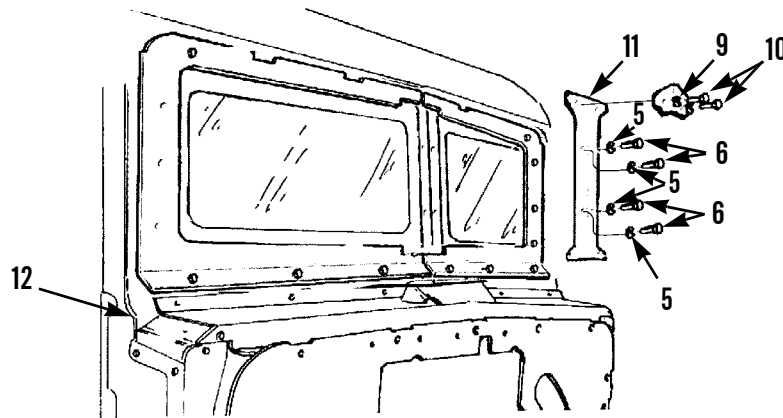
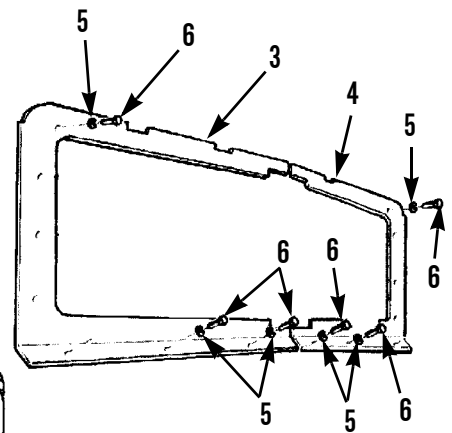
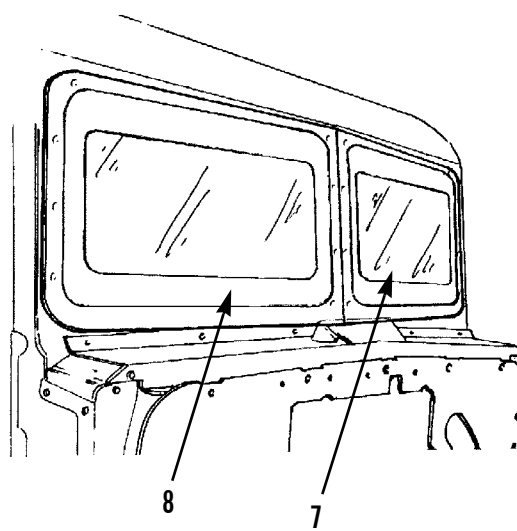
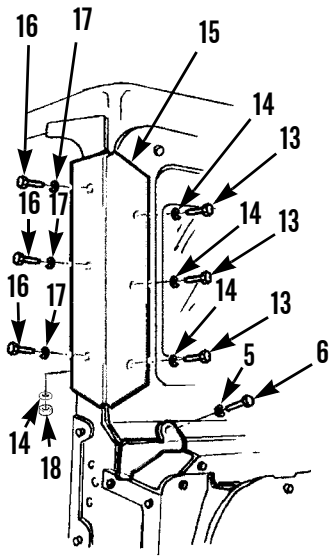
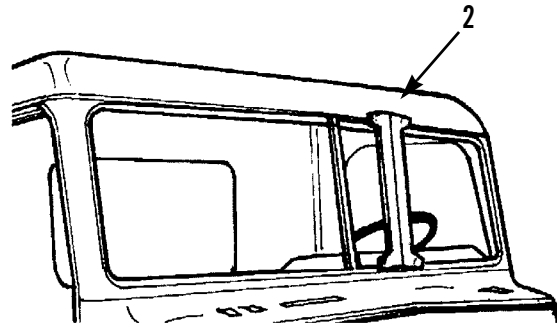


Figure 7. Windscreen Protection Armor Kit (Sheet 1 of 2)

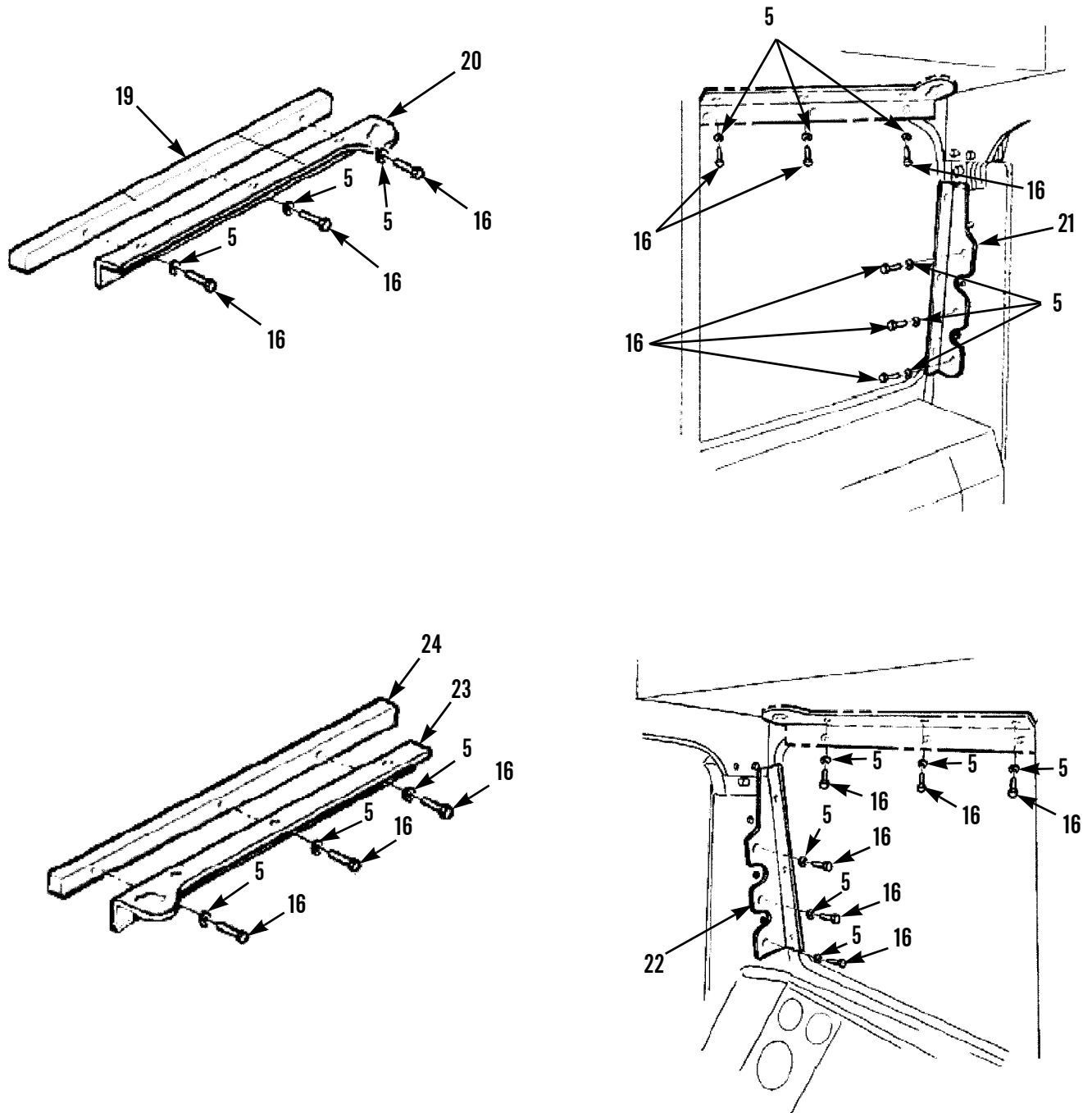


Figure 7. Windscreen Protection Armor Kit (Sheet 2 of 2)

(1) ITEM NO	(2) SMR CODE	(3) NSN	(4) CAGEC	(5) PART NUMBER	(6) DESCRIPTION AND USABLE ON CODES(UOC)	(7) QTY
GROUP 3307 SPECIAL PURPOSE KITS						
FIG. 7 WINDSCREEN PROTECTION ARMOR KIT						
1	PAOZZ	2540015338824	54786	113594-1-103	ARMOR SET,SUPPLEMEN.....	1
2	PFOZZ	2590015339663	54786	0257020625-00	.BRACKET,VEHICULAR C FRONT WINDOW SEALER.....	1
3	PFOZZ	2510015339712	54786	0257027780-00	.FRAME SECTION,WINDO RH.....	1
4	PFOZZ	2510015339713	54786	0257027781-00	.FRAME SECTION,WINDO LH.....	1
5	PAOZZ	5310004923208	61510	4R1604	.WASHER,FLAT 0.312 X 0.900 X 0.125 PART OF KIT P/N 113599-1.....	6
7	PFOZZ	2510015339727	54786	0257020063-00	.WINDOW,VEHICULAR FRONT, RH.....	1
8	PFOZZ		54786	0257000004-00	.WINDOW ASSEMBLY FRONT, LH.....	1
9	PFOZZ	2510015339646	54786	0257017704-00	.FRAME SECTION,WINDO CENTRAL.....	1
10	PAOZZ	5305002264831	80204	B1821BH031C150N	.SCREW,CAP,HEXAGON H 0.312 X 1.50 PART OF KIT P/N 113599-1.....	2
11	PFOZZ	2540015337486	54786	0257027782-00	.ARMOR,SUPPLEMENTAL, CENTRAL.....	1
12	PFOZZ	2510015339624	54786	0257010842-00	.FRAME SECTION,WINDO REAR,RH.....	1
12	PFOZZ	2510015339623	54786	0257010843-00	.FRAME SECTION,WINDO REAR,LH.....	1
13	PAOZZ	5305008213869	80204	B1821BH038C175N	.SCREW,CAP,HEXAGON H 0.375 X 1.750 0.375 X 1.750 PART OF KIT P/N 113599-1.....	6
14	PAOZZ	5310015226093	04664	82-1013-0038	.WASHER,FLAT 0.375 X 0.900 X 0.125. PART OF KIT P/N 113599-1.....	12
15	PFOZZ	2540015338150	54786	0257030846-00	.ARMOR,SUPPLEMENTAL, A-PILLAR, RH..	1
15	PFOZZ	2540015338147	54786	0257030845-00	.ARMOR,SUPPLEMENTAL, A-PILLAR, LH..	1
16	PAOZZ	5305012854924	64678	23-09464-075	.SCREW,CAP,HEXAGON H 0.312 X 0.750 PART OF KIT P/N 113599-1.....	18
17	PAOZZ	5310001585175	82386	400-132	.WASHER,FLAT 0.312 X 1.00 X 0.125... PART OF KIT P/N 113599-1....	18
18	PAOZZ	5310015114533	39428	91030A031	.NUT,PLAIN,EXTENDED 0.375 PART OF KIT P/N 113599-1.....	6
19	PFOZZ	2540015337541	54786	0257020990-00	.ARMOR,SUPPLEMENTAL,.....	1
20	PFOZZ	2510015339626	54786	0257020956-00	.FRAME SECTION,WINDO FRONT FRAME/ ROOF,LH.....	1
21	PFOZZ	2590015339620	54786	0257020958-00	.BRACKET,VEHICULAR C FRONT WINDOW FRAME,LH.....	1
22	PFOZZ	2510015339641	54786	0257020959-00	.FRAME SECTION,WINDO FRONT WINDOW FRAME,RH.....	1
23	PFOZZ	2540015337492	54786	0257020957-00	.ARMOR,SUPPLEMENTAL, FRONT FRAME/ ROOF,RH.....	1
24	PFOZZ	2590015339658	54786	0257020969-00	.BRACKET,VEHICULAR C AIR FILTER....	4
24	PFOZZ	2540015337490	54786	0257020989-00	.ARMOR,SUPPLEMENTAL, WINDSCREEN....	1

END OF FIGURE

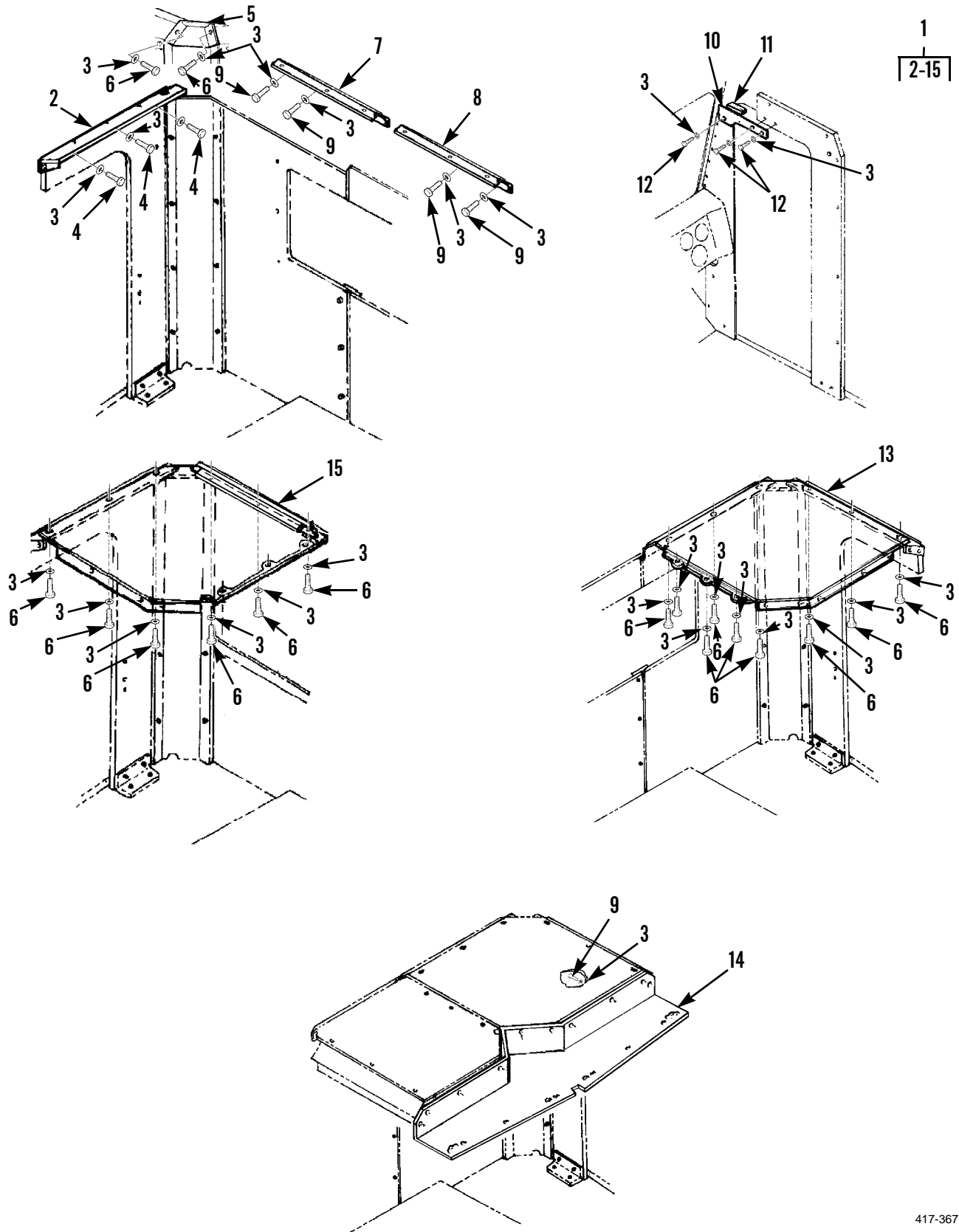


Figure 8. Roof Protection Armor Kit

(1) ITEM NO	(2) SMR CODE	(3) NSN	(4) CAGEC	(5) PART NUMBER	(6) DESCRIPTION AND USABLE ON CODES(UOC)	(7) QTY
GROUP 3307 SPECIAL PURPOSE KITS						
FIG. 8 ROOF PROTECTION ARMOR KIT						
1	PAOZZ	2540015338825	54786	113596-1-103	ARMOR SET,SUPPLEMEN.....	1
2	PFOZZ	2540015337512	54786	0257010803-00	.ARMOR,SUPPLEMENTAL, REAR ROOF,LH, 0257010865-00 ALTERNATE PART NUMBER.	1
2	PFOZZ	2540015337523	54786	0257010802-00	.ARMOR,SUPPLEMENTAL, REAR,RH, 0257010864-00 ALTERNATE PART NUMBER.	1
3	PAOZZ	5310004923208	61510	4R1604	.WASHER,FLAT PART OF KIT P/N 113599- 1.....	47
4	PAOZZ	5305002264831	80204	B1821BH031C150N	.SCREW,CAP,HEXAGON H 0.312 X 1.50 PART OF KIT P/N 113599-1.....	10
5	PFOZZ	2590015339653	54786	0257010801-00	.BRACKET,VEHICULAR C REAR ROOF,RH/ LH.....	2
6	PAOZZ	5305012854924	64678	23-09464-075	.SCREW,CAP,HEXAGON H 0.312 X 0.750 PART OF KIT P/N 113599-1.....	13
7	PFOZZ	2590015338048	54786	0257010828-00	.BRACKET,VEHICULAR C BACKSIDE ROOF, RH,0257010866-11 ALTERNATE PART NUMBER.....	1
9	PAOZZ	5305011972434	75160	19H3053	.SCREW,CAP,HEXAGON H 0.312 X 1.0 PART OF KIT P/N 113599-1.....	16
10	PFOZZ	2590015338045	54786	0257032253-00	BRACKET,VEHICULAR C TOP INTERIOR, RH,0257037353-00 ALTERNATE PART NUMBER.....	1
10	PFOZZ	2590015338047	54786	0257032254-00	.BRACKET,VEHICULAR C TOP INTERNAL, LH,0257037354-00 ALTERNATE PART NUMBER.....	1
11	PFOZZ	5365015338152	54786	0257030951-00	.SPACER,PLATE A-PILLAR, TOP RH.....	1
11	PFOZZ	5365015338158	54786	0257030954-00	.SPACER,PLATE A-PILLAR, TOP LH.....	1
12	PAOZZ	5306002264835	80204	B1821BH031C250N	.BOLT,MACHINE 0.312 X 2.50 PART OF KIT P/N 113599-1.....	3
13	PFOZZ	2540015337464	54786	0257010817-00	.ARMOR,SUPPLEMENTAL, REAR,LH.....	1
14	PFOZZ	2540015337546	54786	0257010804-00	.ARMOR,SUPPLEMENTAL, FRONT.....	1
15	PFOZZ	2540015337540	54786	0257010818-00	.ARMOR,SUPPLEMENTAL, REAR,RH.....	1

END OF FIGURE

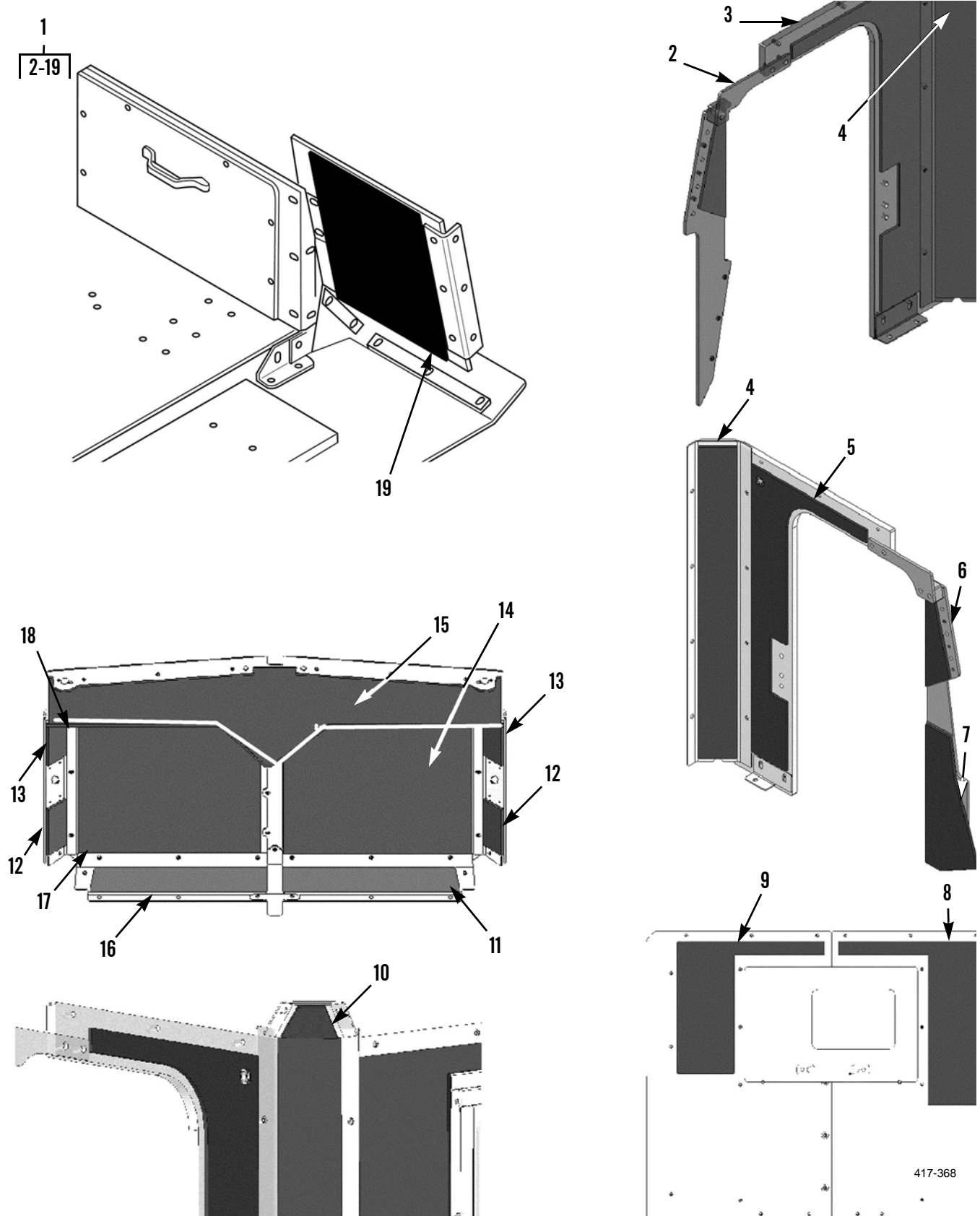


Figure 9. Foam Insulation Kit



(1) ITEM NO	(2) SMR CODE	(3) NSN	(4) CAGEC	(5) PART NUMBER	(6) DESCRIPTION AND USABLE ON CODES(UOC)	(7) QTY
GROUP 3307 SPECIAL PURPOSE KITS						
FIG. 9 FOAM INSULATION KIT						
1	PAOZZ	2540015338828	54786	113598-1-103	ARMOR SET,SUPPLEMEN.....	1
2	PFOZZ	2510015337611	54786	0257950610-00	.INSULATION PANEL,VE RH A-PILLAR, INTERNAL.....	1
3	PFOZZ	2510015337603	54786	0257950616-00	.INSULATION PANEL,VE SIDE,RH.....	1
4	PFOZZ	2540015337474	54786	0257950603-00	.INSULATION PANEL REAR B-PILLAR....	2
5	PFOZZ	2510015337602	54786	0257950615-00	.INSULATION PANEL,VE SIDE,LH.....	1
6	PFOZZ	2510015337600	54786	0257950608-00	.INSULATION PANEL,VE LH A-PILLAR, INTERNAL 1.....	1
7	PFOZZ	2510015337612	54786	0257950609-00	.INSULATION PANEL,VE LH A-PILLAR, INTERNAL 2.....	1
8	PFOZZ	2540015337478	54786	0257950602-00	.INSULATION PANEL REAR WALL,LH.....	1
9	PFOZZ	2540015337475	54786	0257950601-00	.INSULATION PANEL REAR WALL,RH.....	1
10	PFOZZ	2510015337606	54786	0257950618-00	.INSULATION PANEL,VE REAR ROOF, CORNER.....	2
11	PFOZZ	2540015337472	54786	0257950604-00	.INSULATION PANEL REAR ROOF,LH.....	1
12	PFOZZ	2540015337470	54786	0257950606-00	.INSULATION PANEL REAR ROOF OVERLAP,1.....	2
13	PFOZZ	2540015337469	54786	0257950607-00	.INSULATION PANEL REAR ROOF OVERLAP,2.....	2
14	PFOZZ	2510015337608	54786	0257950611-00	.INSULATION PANEL,VE LEFT REAR ROOF	1
15	PFOZZ	2540015337494	54786	0257950613-00	.INSULATION PANEL FRONT ROOF 1.....	1
16	PFOZZ	2540015337471	54786	0257950605-00	.INSULATION PANEL REAR ROOF,RH.....	1
17	PFOZZ	2510015337609	54786	0257950612-00	.INSULATION PANEL,VE RIGHT REAR ROOF.....	1
18	PFOZZ	2540015337482	54786	0257950614-00	.INSULATION PANEL FRONT ROOF 2.....	1
19	PFOZZ	2540015337487	54786	0257950617-00	.INSULATION PANEL INTERNAL FIREWALL,RH.....	1

END OF FIGURE



(1) ITEM NO	(2) SMR CODE	(3) NSN	(4) CAGEC	(5) PART NUMBER	(6) DESCRIPTION AND USABLE ON CODES(UOC)	(7) QTY
-------------------	--------------------	------------	--------------	-----------------------	---	------------

GROUP 94 REPAIR KITS

GROUP 9401 REPAIR KITS

FIG. KIT

PAOZZ 2540015339344 54786 113599-1

				ARMOR SET,SUPPLEMEN.....		1
				BOLT,MACHINE ( 3)	8-12	
				NUT,PLAIN,EXTENDED ( 2)	4-12	
				NUT,PLAIN,EXTENDED ( 2)	1-4	
				NUT,PLAIN,EXTENDED ( 4)	6-21	
				NUT,PLAIN,EXTENDED ( 6)	7-18	
				NUT,PLAIN,EXTENDED ( 12)	2-5	
				NUT,PLAIN,EXTENDED ( 12)	2-3	
				SCREW,CAP,HEXAGON H( 18)	7-16	
				SCREW,CAP,HEXAGON H( 13)	8-6	
				SCREW,CAP,HEXAGON H( 25)	5-11	
				SCREW,CAP,HEXAGON H( 11)	6-2	
				SCREW,CAP,HEXAGON H( 16)	8-9	
				SCREW,CAP,HEXAGON H( 21)	6-22	
				SCREW,CAP,HEXAGON H( 8)	5-14	
				SCREW,CAP,HEXAGON H( 3)	6-27	
				SCREW,CAP,HEXAGON H( 2)	7-10	
				SCREW,CAP,HEXAGON H( 10)	8-4	
				SCREW,CAP,HEXAGON H( 6)	7-13	
				SCREW,CAP,HEXAGON H( 14)	6-18	
				SCREW,CAP,HEXAGON H( 4)	6-16	
				SCREW,CAP,HEXAGON H( 18)	7-17	
				SCREW,CAP,HEXAGON H( 23)	6-14	
				SCREW,CAP,HEXAGON H( 72)	3-6	
				SCREW,CAP,HEXAGON H( 4)	3-22	
				SCREW,CAP,HEXAGON H( 5)	4-11	
				SCREW,CAP,HEXAGON H( 8)	3-26	
				SCREW,CAP,HEXAGON H( 2)	3-13	
				SCREW,CAP,HEXAGON H( 3)	4-4	
				SCREW,CAP,HEXAGON H( 2)	4-2	
				SCREW,CAP,HEXAGON H( 6)	4-22	
				SCREW,CAP,HEXAGON H( 6)	4-24	
				SCREW,CAP,HEXAGON H( 12)	2-9	
				SCREW,CAP,HEXAGON H( 12)	2-10	
				SCREW,CAP,HEXAGON H( 2)	1-8	
				SCREW,MACHINE ( 3)	5-12	
				SCREW,MACHINE ( 4)	6-19	
				WASHER,FLAT ( 12)	7-14	
				WASHER,FLAT ( 47)	8-3	
				WASHER,FLAT ( 72)	3-5	
				WASHER,FLAT ( 10)	4-10	
				WASHER,FLAT ( 33)	5-10	
				WASHER,FLAT ( 18)	6-3	
				WASHER,FLAT ( 6)	7-5	
				WASHER,FLAT ( 45)	6-13	
				WASHER,FLAT ( 4)	5-13	

(1) ITEM NO	(2) SMR CODE	(3) NSN	(4) CAGEC	(5) PART NUMBER	(6) DESCRIPTION AND USABLE ON CODES(UOC)	(7) QTY
					WASHER, FLAT	( 8) 3-27
					WASHER, FLAT	( 7) 4-3
					WASHER, FLAT	( 4) 6-15
					WASHER, FLAT	( 3) 4-5
					WASHER, FLAT	( 14) 6-17
					WASHER, FLAT	( 24) 2-6
					WASHER, FLAT	( 12) 2-2
					WASHER, FLAT	( 2) 1-7
					WASHER, LOCK BLANK	( 12) 2-11
					WASHER, LOCK BLANK	( 2) 1-5
					WASHER, LOCK BLANK	( 12) 2-8

END OF FIGURE

CROSS-REFERENCE INDEXES

NATIONAL STOCK NUMBER INDEX

STOCK NUMBER	FIG.	ITEM	STOCK NUMBER	FIG.	ITEM
5305-00-068-0509	4	4	2540-01-533-7497	5	4
5305-00-071-1786	4	22	2540-01-533-7501	5	3
5305-00-071-2060	4	24	2540-01-533-7503	6	28
5305-00-071-2061	4	2	2540-01-533-7504	6	25
5305-00-071-2070	2	9	2510-01-533-7505	4	27
5310-00-158-5175	6	13	2510-01-533-7507	4	29
5305-00-226-4831	4	11	2540-01-533-7509	6	29
5306-00-226-4835	8	12	2510-01-533-7510	4	17
5305-00-455-9960	5	12	2540-01-533-7512	8	2
5310-00-492-3208	3	5	2540-01-533-7513	4	7
	4	10	2510-01-533-7515	4	27
	5	10	2510-01-533-7516	4	29
	6	3	2540-01-533-7518	4	26
	7	5	2540-01-533-7520	4	6
	8	3	2540-01-533-7523	8	2
5305-00-724-7224	2	10	2540-01-533-7524	6	12
5310-00-763-0254	2	6	2540-01-533-7525	3	21
5310-00-809-0940	4	3	2540-01-533-7528	3	20
	6	15	2540-01-533-7529	3	3
5305-00-821-3869	3	26	2540-01-533-7530	3	2
5310-00-880-5977	6	17	2540-01-533-7534	3	19
5305-00-938-1539	1	8	2540-01-533-7536	3	11
5305-01-197-2434	3	6	2540-01-533-7538	6	5
5310-01-275-6826	1	7	2540-01-533-7539	6	6
5305-01-285-4924	6	14	2540-01-533-7540	8	15
5305-01-335-9277	3	13	2540-01-533-7541	7	19
5310-01-490-6056	1	4	2540-01-533-7546	8	14
5310-01-511-4533	7	18	2510-01-533-7600	9	6
5305-01-514-1091	3	22	2510-01-533-7602	9	5
5310-01-522-6093	3	27	2510-01-533-7603	9	3
2540-01-533-7464	8	13	2510-01-533-7606	9	10
2510-01-533-7469	9	13	2510-01-533-7608	9	14
2510-01-533-7470	9	12	2510-01-533-7609	9	17
2540-01-533-7471	9	16	2540-01-533-7610	3	16
2510-01-533-7472	9	11	2510-01-533-7611	9	2
2540-01-533-7474	9	4	2510-01-533-7612	9	7
2510-01-533-7475	9	9	2540-01-533-7616	6	12
2510-01-533-7478	9	8	2540-01-533-7620	3	24
2540-01-533-7479	2	7	2540-01-533-7623	3	30
2540-01-533-7480	2	7	2540-01-533-7624	3	23
2540-01-533-7481	5	5	2540-01-533-7628	3	31
2510-01-533-7482	9	18	2540-01-533-7631	4	7
2540-01-533-7483	2	4	2540-01-533-7632	3	35
2540-01-533-7486	7	11	2540-01-533-7637	4	20
2510-01-533-7487	9	19	2540-01-533-7640	3	25
2540-01-533-7490	7	24	2540-01-533-7641	3	29
2540-01-533-7492	7	23	2540-01-533-7642	3	28
2540-01-533-7493	6	26	2540-01-533-7644	3	15
2510-01-533-7494	9	15	2540-01-533-7646	3	14
2540-01-533-7495	6	23	5365-01-533-7735	4	21

CROSS-REFERENCE INDEXES

NATIONAL STOCK NUMBER INDEX

STOCK NUMBER	FIG.	ITEM	STOCK NUMBER	FIG.	ITEM
5365-01-533-7737	4	8	5305-01-197-2434	8	9
2540-01-533-7743	4	6	2540-01-533-9344	KITS	
2540-01-533-7848	6	7	2590-01-533-9620	7	21
5365-01-533-8037	6	9	2590-01-533-9622	6	11
2540-01-533-8038	3	18	2510-01-533-9623	7	12
2540-01-533-8042	6	7	2510-01-533-9624	7	12
5365-01-533-8043	4	23	5310-01-533-9625	2	3
5365-01-533-8044	4	25	2510-01-533-9626	7	20
2590-01-533-8045	8	10	2590-01-533-9628	3	17
2590-01-533-8047	8	10	5310-01-533-9629	4	12
2590-01-533-8048	8	7	2590-01-533-9632	4	9
5365-01-533-8052	1	9	5310-01-533-9633	6	21
5340-01-533-8141	1	6	2590-01-533-9634	3	9
2540-01-533-8142	6	4	5310-01-533-9640	2	5
5340-01-533-8143	3	12	2510-01-533-9641	7	22
2540-01-533-8147	7	15	2590-01-533-9642	3	10
2540-01-533-8150	7	15	2590-01-533-9645	3	33
5340-01-533-8151	1	3	2510-01-533-9646	7	9
5365-01-533-8152	8	11	2590-01-533-9648	2	12
5340-01-533-8153	4	28	2590-01-533-9649	2	4
5365-01-533-8158	8	11	2590-01-533-9651	1	2
5310-01-533-8801	5	13	2590-01-533-9653	8	5
2540-01-533-8806	1	1	2590-01-533-9654	4	9
2540-01-533-8810	2	1	2590-01-533-9656	5	2
2540-01-533-8813	3	1	2590-01-533-9657	4	20
2540-01-533-8814	4	1	2590-01-533-9658	6	24
2540-01-533-8816	4	1	2590-01-533-9659	5	6
2540-01-533-8817	5	1	2590-01-533-9660	5	7
2540-01-533-8820	6	1	2590-01-533-9663	7	2
2540-01-533-8824	7	1	2590-01-533-9665	5	8
2540-01-533-8825	8	1	2590-01-533-9667	5	9
2540-01-533-8828	9	1	2590-01-533-9669	3	7
5310-01-533-8858	2	8	2590-01-533-9672	3	4
5310-01-533-8861	1	5	2590-01-533-9673	3	32
5310-01-533-8863	2	11	2590-01-533-9676	3	8
5305-01-197-2434	5	11	2590-01-533-9677	6	10
5305-00-226-4831	5	14	5365-01-533-9708	6	8
5305-01-197-2434	6	2	2510-01-533-9712	7	3
5305-00-071-1786	6	16	2510-01-533-9713	7	4
5305-00-068-0509	6	18	2510-01-533-9721	3	34
5305-00-455-9960	6	19	2510-01-533-9727	7	7
5305-00-514-1091	6	22	2510-01-533-9728	4	17
5305-00-226-4831	6	27	2540-01-533-9730	6	23
	7	10	2540-01-533-9733	4	13
5305-00-821-3869	7	13	5340-01-533-9764	4	14
5310-01-522-6093	7	14	2540-01-534-1097	4	18
5305-01-285-4924	7	16			
5310-00-158-5175	7	17			
5305-00-226-4831	8	4			
5305-01-285-4924	8	6			

CROSS-REFERENCE INDEXES

CAGEC	PART NUMBER	PART NUMBER INDEX		FIG.	ITEM
			STOCK NUMBER		
80204	B1821BH025C125N		5305-00-068-0509	4	4
80204	B1821BH031C150N		5305-00-226-4831	4	11
80204	B1821BH031C250N		5306-00-226-4835	8	12
80204	B1821BH038C175N		5305-00-821-3869	3	26
80204	B1821BH044C100N		5305-00-071-1786	4	22
80204	B1821BH044C275N		5305-00-071-2060	4	24
80204	B1821BH044C300N		5305-00-071-2061	4	2
80204	B1821BH050C175N		5305-00-071-2070	2	9
80204	B1821BH063C250N		5305-00-724-7224	2	10
80204	B1821BH075C200N		5305-00-938-1539	1	8
19207	KIT #1		2540-01-533-8806	1	1
80205	MS15795-811		5310-00-880-5977	6	17
80205	MS24693-C120		5305-00-455-9960	5	12
96906	MS27183-21			2	2
96906	MS51491-013		5305-01-514-1091	3	22
86727	OEM 7238		5310-01-533-8858	2	8
54786	025100978-00		5340-01-533-8141	1	6
54786	0257000004-00			7	8
54786	02570044401-00		2540-01-534-1097	4	18
54786	02570044403-00			4	19
54786	0257010012-00		2540-01-533-9733	4	13
54786	0257010801-00		2590-01-533-9653	8	5
54786	0257010802-00		2540-01-533-7523	8	2
54786	0257010803-00		2540-01-533-7512	8	2
54786	0257010804-00		2540-01-533-7546	8	14
54786	0257010817-00		2540-01-533-7464	8	13
54786	0257010818-00		2540-01-533-7540	8	15
54786	0257010828-00		2590-01-533-8048	8	7
54786	0257010842-00		2510-01-533-9624	7	12
54786	0257010843-00		2510-01-533-9623	7	12
54786	0257017703-00		2590-01-533-9645	3	33
54786	0257017704-00		2510-01-533-9646	7	9
54786	0257020063-00		2510-01-533-9727	7	7
54786	0257020625-00		2590-01-533-9663	7	2
54786	0257020806-00		2540-01-533-7493	6	26
54786	0257020810-00		2540-01-533-7538	6	5
54786	0257020811-00		2540-01-533-7529	3	3
54786	0257020813-00		2540-01-533-7610	3	16
54786	0257020814-00		2590-01-533-9634	3	9
54786	0257020830-00		2540-01-533-8142	6	4
54786	0257020831-00		2540-01-533-7539	6	6
54786	0257020832-00		2540-01-533-7495	6	23
54786	0257020833-00		2540-01-533-9730	6	23
54786	0257020955-00		5365-01-533-9708	6	8
54786	0257020956-00		2510-01-533-9626	7	20
54786	0257020957-00		2540-01-533-7492	7	23
54786	0257020958-00		2590-01-533-9620	7	21
54786	0257020959-00		2510-01-533-9641	7	22
54786	0257020969-00		2590-01-533-9658	6	24
54786	0257020972-00		2540-01-533-7536	3	11

## CROSS-REFERENCE INDEXES

CAGEC	PART NUMBER	PART NUMBER INDEX		FIG.	ITEM
			STOCK NUMBER		
54786	0257020981-00		2590-01-533-9676	3	8
54786	0257020982-00		2590-01-533-9672	3	4
54786	0257020988-00		2590-01-533-9628	3	17
54786	0257020989-00		2540-01-533-7490	7	24
54786	0257020990-00		2540-01-533-7541	7	19
54786	0257022262-00		2540-01-533-7509	6	29
54786	0257022265-00		2540-01-533-8038	3	18
54786	0257022266-00		2540-01-533-7534	3	19
54786	0257022268-00		2540-01-533-7525	3	21
54786	0257027706-00		2540-01-533-7504	6	25
54786	0257027763-00		2540-01-533-7503	6	28
54786	0257027780-00		2510-01-533-9712	7	3
54786	0257027781-00		2510-01-533-9713	7	4
54786	0257027782-00		2540-01-533-7486	7	11
54786	0257027793-00		2540-01-533-7530	3	2
54786	0257030819-00		2540-01-533-7616	6	12
54786	0257030820-00		2540-01-533-7524	6	12
54786	0257030826-00		2540-01-533-7481	5	5
54786	0257030827-00		2590-01-533-9656	5	2
54786	0257030845-00		2540-01-533-8147	7	15
54786	0257030846-00		2540-01-533-8150	7	15
54786	0257030951-00		5365-01-533-8152	8	11
54786	0257030952-00		2540-01-533-7637	4	20
54786	0257030953-00		2590-01-533-9657	4	20
54786	0257030954-00		5365-01-533-8158	8	11
54786	0257030960-00		5365-01-533-8037	6	9
54786	0257030962-00		2590-01-533-9654	4	9
54786	0257030963-00		2590-01-533-9632	4	9
54786	0257030964-00		5340-01-533-9764	4	14
54786	0257030965-00		2590-01-533-9677	6	10
54786	0257030966-00		2590-01-533-9622	6	11
54786	0257030991-00		5365-01-533-7735	4	21
54786	0257030992-00		5365-01-533-7737	4	8
54786	0257032213-00		2540-01-533-7631	4	7
54786	0257032214-00		2540-01-533-7513	4	7
54786	0257032250-00		2540-01-533-7743	4	6
54786	0257032251-00		2540-01-533-7520	4	6
54786	0257032253-00		2590-01-533-8045	8	10
54786	0257032254-00		2590-01-533-8047	8	10
54786	0257032255-00		2540-01-533-7848	6	7
54786	0257032256-00		2540-01-533-8042	6	7
54786	0257040001-00		2510-01-533-9728	4	17
54786	0257040002-00		2510-01-533-7510	4	17
54786	0257040009-00		5340-01-533-8153	4	28
54786	0257040912-00			4	15
54786	0257040913-00			4	15
54786	0257040914-00		5365-01-533-8043	4	23
54786	0257040915-00		5365-01-533-8044	4	25
54786	0257040916-00		2540-01-533-7518	4	26
54786	0257040922-00		2510-01-533-7507	4	29



CROSS-REFERENCE INDEXES

CAGEC	PART NUMBER	PART NUMBER INDEX		FIG.	ITEM
			STOCK NUMBER		
54786	0257040923-00		2510-01-533-7516	4	29
54786	0257040924-00		2510-01-533-7505	4	27
54786	0257040925-00		2510-01-533-7515	4	27
54786	0257044404-00			4	18
54786	0257047760-00			4	16
54786	0257060065-00		2540-01-533-7632	3	35
54786	0257060844-00		2540-01-533-7497	5	4
54786	0257060968-00		2510-01-533-9721	3	34
54786	0257060980-00		2590-01-533-9660	5	7
54786	0257062205-00		2540-01-533-7501	5	3
54786	0257120805-00		2540-01-533-7642	3	28
54786	0257120815-00		2540-01-533-7628	3	31
54786	0257120816-00		2540-01-533-7641	3	29
54786	0257120849-00		2540-01-533-7640	3	25
54786	0257120850-00		2540-01-533-7623	3	30
54786	0257120973-00		2590-01-533-9642	3	10
54786	0257120974-00		2540-01-533-7624	3	23
54786	0257120975-00		2540-01-533-7620	3	24
54786	0257120976-00		2590-01-533-9669	3	7
54786	0257120983-00		2590-01-533-9667	5	9
54786	0257120984-00		2590-01-533-9659	5	6
54786	0257120985-00		2540-01-533-7528	3	20
54786	0257120986-00		2590-01-533-9673	3	32
54786	0257120987-00		2590-01-533-9665	5	8
54786	0257120993-00			3	36
54786	0257122227-00		2540-01-533-7644	3	15
54786	0257127725-00		2540-01-533-7646	3	14
54786	0257950601-00		2510-01-533-7475	9	9
54786	0257950602-00		2510-01-533-7478	9	8
54786	0257950603-00		2540-01-533-7474	9	4
54786	0257950604-00		2510-01-533-7472	9	11
54786	0257950605-00		2540-01-533-7471	9	16
54786	0257950606-00		2510-01-533-7470	9	12
54786	0257950607-00		2510-01-533-7469	9	13
54786	0257950608-00		2510-01-533-7600	9	6
54786	0257950609-00		2510-01-533-7612	9	7
54786	0257950610-00		2510-01-533-7611	9	2
54786	0257950611-00		2510-01-533-7608	9	14
54786	0257950612-00		2510-01-533-7609	9	17
54786	0257950613-00		2510-01-533-7494	9	15
54786	0257950614-00		2510-01-533-7482	9	18
54786	0257950615-00		2510-01-533-7602	9	5
54786	0257950616-00		2510-01-533-7603	9	3
54786	0257950617-00		2510-01-533-7487	9	19
54786	0257950618-00		2510-01-533-7606	9	10
54786	0257970006-00		2540-01-533-7480	2	7
54786	0257970007-00		2540-01-533-7479	2	7
54786	0257970010-00		2590-01-533-9651	1	2
54786	0257970624-00		5365-01-533-8052	1	9
54786	0257970967-00		2590-01-533-9648	2	12

CROSS-REFERENCE INDEXES

CAGEC	PART NUMBER	PART NUMBER INDEX		FIG.	ITEM
			STOCK NUMBER		
54786	0257970970-00		2590-01-533-9649	2	4
54786	0257970971-00		2540-01-533-7483	2	4
54786	113582-1-103		2540-01-533-8810	2	1
54786	113584-1-103		2540-01-533-8813	3	1
54786	113586-1-103		2540-01-533-8814	4	1
54786	113588-1-103		2540-01-533-8816	4	1
54786	113590-1-103		2540-01-533-8817	5	1
54786	113592-1-103		2540-01-533-8820	6	1
54786	113594-1-103		2540-01-533-8824	7	1
54786	113596-1-103		2540-01-533-8825	8	1
54786	113598-1-103		2540-01-533-8828	9	1
75160	19H3053		5305-01-197-2434	5	11
80204	B1821BH031C150N		5305-00-226-4831	5	14
75160	19H3053		5305-01-197-2434	6	2
80204	B1821BH044C100N		5305-00-071-1786	6	16
80204	B1821BH025C125N		5305-00-068-0509	6	18
80205	MS24693-C120		5305-00-455-9960	6	19
96906	MS51491-013		5305-01-514-1091	6	22
80204	B1821BH031C150N		5305-00-226-4831	6	27
80204	B1821BH031C150N		5305-00-226-4831	7	10
80204	B1821BH038C175N		5305-00-821-3869	7	13
04664	82-1013-0038		5310-01-522-6093	7	14
64678	23-09464-075		5305-01-285-4924	7	16
82386	400-132		5310-00-158-5175	7	17
80204	B1821BH031C150N		5305-00-226-4831	8	4
64678	23-09464-075		5305-01-285-4924	8	6
75160	19H3053		5305-01-197-2434	8	9
54786	113599-1		2540-01-053-9344	KITS	
02978	15X3XX1353		5310-00-809-0940	4	3
				6	15
65525	16/206-12		5310-01-275-6826	1	7
75160	19H3053		5305-01-197-2434	3	6
43999	2W2SP16-32-125		5310-00-763-0254	2	6
64678	23-09464-075		5305-01-285-4924	6	14
61510	4R1604		5310-00-492-3208	3	5
				4	10
				5	10
				6	3
				7	5
				8	3
82386	400-132		5310-00-158-5175	6	13
82386	400-20MZ			4	5
54786	5320000103-00		5310-01-533-8863	2	11
54786	5320000105-00		5310-01-533-8861	1	5
54786	5340000106-00		5340-01-533-8143	3	12
54786	534000179-00		5340-01-533-8151	1	3
04664	82-1013-0038		5310-01-522-6093	3	27
39428	91030A029		5310-01-533-9633	6	21
39428	91030A031		5310-01-511-4533	7	18
39428	91030A033		5310-01-533-9640	2	5

CROSS-REFERENCE INDEXES

CAGEC	PART NUMBER	PART NUMBER INDEX		FIG.	ITEM
			STOCK NUMBER		
39428	91030A035		5310-01-533-9625	2	3
3A054	91030A036		5310-01-490-6056	1	4
39428	91030A435		5310-01-533-9629	4	12
39428	91255A540		5305-01-335-9277	3	13
39428	95221A111		5310-01-533-8801	5	13



**INDEX**

<i>Subject</i>	<i>Work Package/Page</i>
<b>A</b>	
Abbreviations/Acronyms, List of .....	0001 00-2
A-Pillar Armor Replacement .....	0022 00-1
Applying Torque .....	0011 00-5
Armor Replacement	
A-Pillar .....	0022 00-1
Firewall .....	0026 00-1
Floor .....	0019 00-1
Front .....	0029 00-1
Left Side .....	0021 00-1
Rear .....	0023 00-1
Right Side .....	0020 00-1
Roof .....	0024 00-1
<b>C</b>	
Cab Support Reinforcement Replacement .....	0017 00-1
Cleaning	
Ballistic Glass .....	0010 00-1
Instructions .....	0011 00-2
Corrosion Prevention and Control (CPC) .....	0001 00-1
Cowl Armor Replacement .....	0028 00-1
Crew Protection Kit Installation Instructions .....	0036 00-1
<b>D</b>	
Description and Use of Operator’s Controls and Indicators .....	0004 00-1
Destruction of Army Materiel to Prevent Enemy Use .....	0001 00-1
Door	
Assembly Replacement .....	0012 00-1
Ballistic Glass and Frame Assembly Replacement .....	0015 00-1
Handle Replacement .....	0013 00-1
Latch Adjustment .....	0016 00-1
Latch Replacement .....	0014 00-1
<b>E</b>	
Equipment Characteristics, Capabilities, and Features .....	0002 00-1
Escape Hatch	
Operation .....	0006 00-1
Replacement .....	0027 00-1
Expendable and Durable Items List .....	0034 00-1
Explanation of Table Entries .....	0008 00-1

**INDEX - Continued**

<i>Subject</i>	<i>Work Package/Page</i>
<b>F</b>	
Firewall Armor Replacement .....	0026 00-1
Floor Armor Replacement .....	0019 00-1
Foam Insulation Replacement .....	0030 00-1
Front Armor Replacement .....	0029 00-1
<b>G</b>	
General Information .....	0011 00-2
General Maintenance Instructions .....	0011 00-1
General PMCS Procedures .....	0008 00-1
<b>I</b>	
Initial Adjustments and Daily Checks .....	0005 00-1
Inspection Instructions .....	0011 00-3
<b>L</b>	
Left Side Armor Replacement .....	0021 00-1
List of Abbreviations/Acronyms .....	0001 00-2
Location and Description of Major Components .....	0002 00-2
<b>M</b>	
Maintenance Allocation Chart (MAC)	
Introduction .....	0032 00-1
Tables .....	0033 00-1
Maintenance Forms, Records, and Reports .....	0001 00-1
<b>O</b>	
Operating Vehicle .....	0005 00-1
Operation	
Under Unusual Conditions .....	0006 00-1
Under Usual Conditions .....	0005 00-1
Operation in Extreme Temperatures .....	0006 00-2
Operator Preventive Maintenance Checks and Services (PMCS)	
Introduction .....	0008 00-1
Procedures .....	0009 00-1
Operator's Controls and Indicators .....	0004 00-1
<b>P</b>	
Painting Instructions .....	0011 00-4
Preparation for Storage or Shipment .....	0001 00-2

**INDEX - Continued**

<i>Subject</i>	<i>Work Package/Page</i>
<b>Q</b>	
Quality of Material .....	0001 00-2
<b>R</b>	
Rear Armor Replacement .....	0023 00-1
References .....	0031 00-1
Repair Parts and Special Tools Lists Introduction .....	0037 00-1
Reporting Equipment Improvement Recommendations (EIRs) .....	0001 00-1
Right Side Armor Replacement .....	0020 00-1
Roof Armor Replacement .....	0024 00-1
<b>S</b>	
Safety, Care, and Handling .....	0001 00-2
Standard Tool Requirements .....	0011 00-4
Storage or Shipment, Preparation for .....	0001 00-2
Stowage and Decal/Data Plate Guide .....	0007 00-1
<b>T</b>	
Tagging Instructions .....	0011 00-5
Theory of Operation .....	0003 00-1
Torque Limits .....	0035 00-1
<b>U</b>	
Use of	
Sealant .....	0011 00-5
Thread Adhesive .....	0011 00-4
<b>W</b>	
Wheel Zone Deflector Replacement .....	0018 00-1
Windshield Ballistic Glass Replacement .....	0025 00-1
Work Safety .....	0011 00-1






By Order of the Secretary of the Army:

PETER J. SCHOOMAKER  
*General, United States Army*  
*Chief of Staff*

Official:

  
JOYCE E. MORROW  
*Administrative Assistant to the*  
*Secretary of the Army*  
0607434

**DISTRIBUTION:** To be distributed in accordance with the initial distribution requirements for IDN: 344848, requirements for TB 9-2320-302-13&P-1.



<b>RECOMMENDED CHANGES TO PUBLICATIONS AND BLANK FORMS</b> For use of this form, see AR 25-30; the proponent agency is ODISC4.						Use Part II ( <i>reverse</i> ) for Repair Parts and Special Tool Lists (RPSTL) and Supply Catalogs/Supply Manuals (SC/SM).	DATE Date you filled out this form.
TO: ( <i>Forward to proponent of publication or form</i> ) ( <i>Include ZIP Code</i> ) AMSTA-LC-LPIT / TECH PUBS, TACOM-RI 1 Rock Island Arsenal Rock Island, IL 61299-7630						FROM: ( <i>Activity and location</i> ) ( <i>Include ZIP Code</i> ) Your mailing address	
<b>PART I – ALL PUBLICATIONS (EXCEPT RPSTL AND SC/SM) AND BLANK FORMS</b>							
PUBLICATION/FORM NUMBER						DATE	
ITEM NO.	PAGE NO.	PARA-GRAPH	LINE NO. *	FIGURE NO.	TABLE NO.	RECOMMENDED CHANGES AND REASON (Provide exact wording of recommended changes, if possible).	
<b>SAMPLE</b>							
<i>*Reference to line numbers within the paragraph or subparagraph.</i>							
TYPED NAME, GRADE OR TITLE Your Name				TELEPHONE EXCHANGE/AUTOVON, PLUS EXTENSION		SIGNATURE Your Signature	

<b>TO:</b> <i>(Forward direct to addressee listed in publication)</i> AMSTA-LC-LPIT / TECH PUBS, TACOM-RI 1 Rock Island Arsenal Rock Island, IL 61299-7630	<b>FROM:</b> <i>(Activity and location) (Include ZIP Code)</i> Your address	<b>DATE</b> Date you filled out this form
---	--	--

**PART II – REPAIR PARTS AND SPECIAL TOOL LISTS AND SUPPLY CATALOGS/SUPPLY MANUALS**

PUBLICATION NUMBER					DATE			TITLE	
PAGE NO.	COLM NO.	LINE NO.	NATIONAL STOCK NUMBER	REFERENCE NO.	FIGURE NO.	ITEM NO.	TOTAL NO. OF MAJOR ITEMS SUPPORTED	RECOMMENDED ACTION	

**PART III – REMARKS** *(Any general remarks or recommendations, or suggestions for improvement of publications and blank forms. Additional blank sheets may be used if more space is needed.)*

TYPED NAME, GRADE OR TITLE  Your Name	TELEPHONE EXCHANGE/AUTOVON, PLUS EXTENSION	SIGNATURE  Your Signature
---	--	---------------------------------

<b>RECOMMENDED CHANGES TO PUBLICATIONS AND BLANK FORMS</b>	Use Part II ( <i>reverse</i> ) for Repair Parts and Special Tools Lists ( <i>RPSTL</i> ) and Supply Catalogs/Supply Manuals ( <i>SC/SM</i> )	DATE
For use of this form, see AR 25-30; the proponent agency is ODISC4.		
TO: ( <i>Forward to proponent of publication or form</i> ) ( <i>Include ZIP Code</i> ) AMSTA-LC-LMPP / TECH PUBS, TACOM-RI 1 Rock Island Arsenal Rock Island, IL 61299-7630	FROM: ( <i>Activity and location</i> ) ( <i>Include ZIP Code</i> )	

**PART I—ALL PUBLICATIONS (EXCEPT RPSTL AND SC/SM) AND BLANK FORMS**

PUBLICATION NUMBER	DATE	TITLE
TM 9-2320-302-13&P-1	30 November 2006	CREW PROTECTION KIT

ITEM NO.	PAGE NO.	PARA-GRAPH	LINE NO.*	FIGURE NO.	TABLE NO.	RECOMMENDED CHANGES AND REASON ( <i>Provide exact wording of recommended changes, if possible.</i> )

*\*Reference to line numbers within the paragraph or subparagraph*

TYPED NAME, GRADE OR TITLE	TELEPHONE EXCHANGE/AUTOVON, PLUS EXTENSION	SIGNATURE

<b>TO:</b> <i>(Forward direct to addressee listed in publication)</i> AMSTA-LC-LMPP / TECH PUBS, TACOM-RI 1 Rock Island Arsenal Rock Island, IL 61299-7630	<b>FROM:</b> <i>(Activity and location) (Include Zip Code)</i>	<b>DATE</b>
---	--	-------------

**PART II—REPAIR PARTS AND SPECIAL TOOL LISTS AND SUPPLY CATALOGS/SUPPLY MANUALS**

PUBLICATION NUMBER			DATE				TITLE	
TM 9-2320-302-13&P-1			30 November 2006				CREW PROTECTION KIT	
PAGE NO.	COLM NO.	LINE NO.	NATIONAL STOCK NUMBER	REFERENCE NO.	FIGURE NO.	ITEM NO.	TOTAL NO. OF MAJOR ITEMS SUPPORTED	RECOMMENDED ACTION

**PART III—REMARKS** *(Any general remarks or recommendations, or suggestions for improvement of publications and blank forms. Additional blank sheets may be used if more space is needed.)*

TYPED NAME, GRADE OR TITLE	TELEPHONE EXCHANGE/AUTOVON, PLUS EXTENSION	SIGNATURE

<b>RECOMMENDED CHANGES TO PUBLICATIONS AND BLANK FORMS</b>	Use Part II ( <i>reverse</i> ) for Repair Parts and Special Tools Lists ( <i>RPSTL</i> ) and Supply Catalogs/Supply Manuals ( <i>SC/SM</i> )	DATE
For use of this form, see AR 25-30; the proponent agency is ODISC4.		
TO: ( <i>Forward to proponent of publication or form</i> ) ( <i>Include ZIP Code</i> ) AMSTA-LC-LMPP / TECH PUBS, TACOM-RI 1 Rock Island Arsenal Rock Island, IL 61299-7630	FROM: ( <i>Activity and location</i> ) ( <i>Include ZIP Code</i> )	

**PART I—ALL PUBLICATIONS (EXCEPT RPSTL AND SC/SM) AND BLANK FORMS**

PUBLICATION NUMBER	DATE	TITLE
TM 9-2320-302-13&P-1	30 November 2006	CREW PROTECTION KIT

ITEM NO.	PAGE NO.	PARA-GRAPH	LINE NO.*	FIGURE NO.	TABLE NO.	RECOMMENDED CHANGES AND REASON ( <i>Provide exact wording of recommended changes, if possible.</i> )

*\*Reference to line numbers within the paragraph or subparagraph*

TYPED NAME, GRADE OR TITLE	TELEPHONE EXCHANGE/AUTOVON, PLUS EXTENSION	SIGNATURE

<b>TO:</b> <i>(Forward direct to addressee listed in publication)</i> AMSTA-LC-LMPP / TECH PUBS, TACOM-RI 1 Rock Island Arsenal Rock Island, IL 61299-7630	<b>FROM:</b> <i>(Activity and location) (Include Zip Code)</i>	<b>DATE</b>
---	--	-------------

**PART II—REPAIR PARTS AND SPECIAL TOOL LISTS AND SUPPLY CATALOGS/SUPPLY MANUALS**

PUBLICATION NUMBER			DATE				TITLE	
TM 9-2320-302-13&P-1			30 November 2006				CREW PROTECTION KIT	
PAGE NO.	COLM NO.	LINE NO.	NATIONAL STOCK NUMBER	REFERENCE NO.	FIGURE NO.	ITEM NO.	TOTAL NO. OF MAJOR ITEMS SUPPORTED	RECOMMENDED ACTION

**PART III—REMARKS** *(Any general remarks or recommendations, or suggestions for improvement of publications and blank forms. Additional blank sheets may be used if more space is needed.)*

TYPED NAME, GRADE OR TITLE	TELEPHONE EXCHANGE/AUTOVON, PLUS EXTENSION	SIGNATURE



<b>RECOMMENDED CHANGES TO PUBLICATIONS AND BLANK FORMS</b>	Use Part II ( <i>reverse</i> ) for Repair Parts and Special Tools Lists ( <i>RPSTL</i> ) and Supply Catalogs/Supply Manuals ( <i>SC/SM</i> )	DATE
For use of this form, see AR 25-30; the proponent agency is ODISC4.		
TO: ( <i>Forward to proponent of publication or form</i> ) ( <i>Include ZIP Code</i> ) AMSTA-LC-LMPP / TECH PUBS, TACOM-RI 1 Rock Island Arsenal Rock Island, IL 61299-7630	FROM: ( <i>Activity and location</i> ) ( <i>Include ZIP Code</i> )	

**PART I—ALL PUBLICATIONS (EXCEPT RPSTL AND SC/SM) AND BLANK FORMS**

PUBLICATION NUMBER	DATE	TITLE
TM 9-2320-302-13&P-1	30 November 2006	CREW PROTECTION KIT

ITEM NO.	PAGE NO.	PARA-GRAPH	LINE NO.*	FIGURE NO.	TABLE NO.	RECOMMENDED CHANGES AND REASON ( <i>Provide exact wording of recommended changes, if possible.</i> )

*\*Reference to line numbers within the paragraph or subparagraph*

TYPED NAME, GRADE OR TITLE	TELEPHONE EXCHANGE/AUTOVON, PLUS EXTENSION	SIGNATURE

<b>TO:</b> <i>(Forward direct to addressee listed in publication)</i> AMSTA-LC-LMPP / TECH PUBS, TACOM-RI 1 Rock Island Arsenal Rock Island, IL 61299-7630	<b>FROM:</b> <i>(Activity and location) (Include Zip Code)</i>	<b>DATE</b>
---	--	-------------

**PART II—REPAIR PARTS AND SPECIAL TOOL LISTS AND SUPPLY CATALOGS/SUPPLY MANUALS**

PUBLICATION NUMBER			DATE				TITLE	
TM 9-2320-302-13&P-1			30 November 2006				CREW PROTECTION KIT	
PAGE NO.	COLM NO.	LINE NO.	NATIONAL STOCK NUMBER	REFERENCE NO.	FIGURE NO.	ITEM NO.	TOTAL NO. OF MAJOR ITEMS SUPPORTED	RECOMMENDED ACTION

**PART III—REMARKS** *(Any general remarks or recommendations, or suggestions for improvement of publications and blank forms. Additional blank sheets may be used if more space is needed.)*

TYPED NAME, GRADE OR TITLE	TELEPHONE EXCHANGE/AUTOVON, PLUS EXTENSION	SIGNATURE

## THE METRIC SYSTEM AND EQUIVALENTS

<p><b>Linear Measure</b></p> <p>1 Centimeter = 10 Millimeters = 0.01 Meters = 0.3937 Inches          1 Meter = 100 Centimeters = 1000 Millimeters = 39.37 Inches          1 Kilometer = 1000 Meters = 0.621 Miles</p> <p><b>Weights</b></p> <p>1 Gram = 0.001 Kilograms = 1000 Milligrams = 0.035 Ounces          1 Kilogram = 1000 Grams = 2.2 Pounds          1 Metric Ton = 1000 Kilograms = 1 Megagram = 1.1 Short Tons</p> <p><b>Liquid Measure</b></p> <p>1 Milliliter = 0.001 Liters = 0.0338 Fluid Ounces          1 Liter = 1000 Milliliters = 33.82 Fluid Ounces</p>	<p><b>Square Measure</b></p> <p>1 Sq Centimeter = 100 Sq Millimeters = 0.155 Sq Inches          1 Sq Meter = 10,000 Sq Centimeters = 10.76 Sq Feet          1 Sq Kilometer = 1,000,000 Sq Meters = 0.386 Sq Miles</p> <p><b>Cubic Measure</b></p> <p>1 Cu Centimeter = 1,000 Cu Millimeters = 0.06 Cu Inches          1 Cu Meter = 1,000,000 Cu Centimeters = 35.31 Cu Feet</p> <p><b>Temperature</b></p> <p><math>5/9 (^{\circ}\text{F} - 32) = ^{\circ}\text{C}</math>          212° Fahrenheit is equivalent to 100° Celsius          90° Fahrenheit is equivalent to 32.2° Celsius          32° Fahrenheit is equivalent to 0° Celsius  <math>9/5 \text{ C}^{\circ} + 32 = \text{F}^{\circ}</math></p>
--	--

## APPROXIMATE CONVERSION FACTORS

To Change	To	Multiply By
Inches	Centimeters	2.540
Feet	Meters	0.305
Yards	Meters	0.914
Miles	Kilometers	1.609
Sq Inches	Sq Centimeters	6.451
Sq Feet	Sq Meters	0.093
Sq Yards	Sq Meters	0.836
Sq Miles	Sq Kilometers	2.590
Acres	Sq Hectometers	0.405
Cubic Feet	Cubic Meters	0.028
Cubic Yards	Cubic Meters	0.765
Fluid Ounces	Milliliters	29.573
Pints	Liters	0.473
Quarts	Liters	0.946
Gallons	Liters	3.785
Ounces	Grams	28.349
Pounds	Kilograms	0.454
Short Tons	Metric Tons	0.907
Pound-Feet	Newton-Meters	1.356
Pounds per Sq Inch	Kilopascals	6.895
Miles per Gallon	Kilometers per Liter	0.425
Miles per Hour	Kilometers per Hour	1.609

To Change	To	Multiply By
Centimeters	Inches	0.394
Meters	Feet	3.280
Meters	Yards	1.094
Kilometers	Miles	0.621
Sq Centimeters	Sq Inches	0.155
Sq Meters	Sq Feet	10.764
Sq Meters	Sq Yards	1.196
Sq Kilometers	Sq Miles	0.386
Sq Hectometers	Acres	2.471
Cubic Meters	Cubic Feet	35.315
Cubic Meters	Cubic Yards	1.308
Milliliters	Fluid Ounces	0.034
Liters	Pints	2.113
Liters	Quarts	1.057
Liters	Gallons	0.264
Grams	Ounces	0.035
Kilograms	Pounds	2.205
Metric Tons	Short Tons	1.102
Newton-Meters	Pound-Feet	0.738
Kilopascals	Pounds per Sq Inch	0.145
Kilometers per Liter	Miles per Gallon	2.354
Kilometers per Hour	Miles per Hour	0.621

PIN: 083145-000